

Chapter 9

ROTARY INVERTERS, TYPE 201 SERIES

LIST OF CONTENTS

	<i>Para.</i>		<i>Para.</i>
<i>Introduction</i>	1	Operation	
Description	2	<i>Starting</i>	21
<i>Inverter unit</i>	4	Servicing	
<i>Control box</i>	7	<i>General</i>	26
<i>Cooling</i>	8	<i>Brushgear</i>	27
<i>Output control</i>	10	<i>Bearings</i>	28
<i>Functioning</i>	11	<i>Insulation resistance test</i>	29
Installation			
<i>General</i>	20		

LIST OF ILLUSTRATIONS

	<i>Fig.</i>		<i>Fig.</i>
<i>General view of inverter</i>	1	<i>Sectional view of brushgear</i>	3
<i>Sectional view of inverter</i>	2	<i>Circuit diagram</i>	4

LIST OF APPENDICES

	<i>App.</i>		<i>App.</i>
<i>Rotary inverter Type 201...</i>	1	<i>Rotary inverter Type 201B</i>	3
<i>Rotary inverter Type 201A</i>	2		

Introduction

1. The Type 201 series of rotary inverters is designed to produce a supply for radio equipment; it has an output of 1750 volt-amps. at 115, volts a.c. unity power factor, frequency is 1600 c.p.s. at a speed of 8000 r.p.m. The d.c. input must be within the specified range as stipulated in the appropriate appendix to this chapter. The output voltage and frequency are controlled by an electronic regulator Type 2A or 2B which are described in Book 1, Sect. 5 of this publication.

DESCRIPTION

2. A typical inverter the Type 201, is illustrated in fig. 1 and 2, it consists of a d.c. motor driving a 2 kVA, 115-volt, 1600 c.p.s. single-phase inductor type a.c. generator, both mounted on a common shaft. The inverter is fitted with a control box, which

contains a two leg single-stage suppressor in series with the d.c. input, also starting relays and associated resistances. The whole equipment is climatically proofed.

3. The d.c. supply enters the inverter by a 2-way terminal box on the side of the control box. On the end face is fitted a 12-pole miniature type socket, Mk. 4, for making the connection to the electronic regulator and a 2-pin socket through which the 115-volt a.c. output leaves the inverter.

Inverter unit

4. The inverter unit comprises a d.c. motor driving an a.c. generator, the motor armature and a.c. rotor being mounted on a common shaft. The main frame is a casting which houses the windings for the d.c. field system and the a.c. stator; the various leads are taken

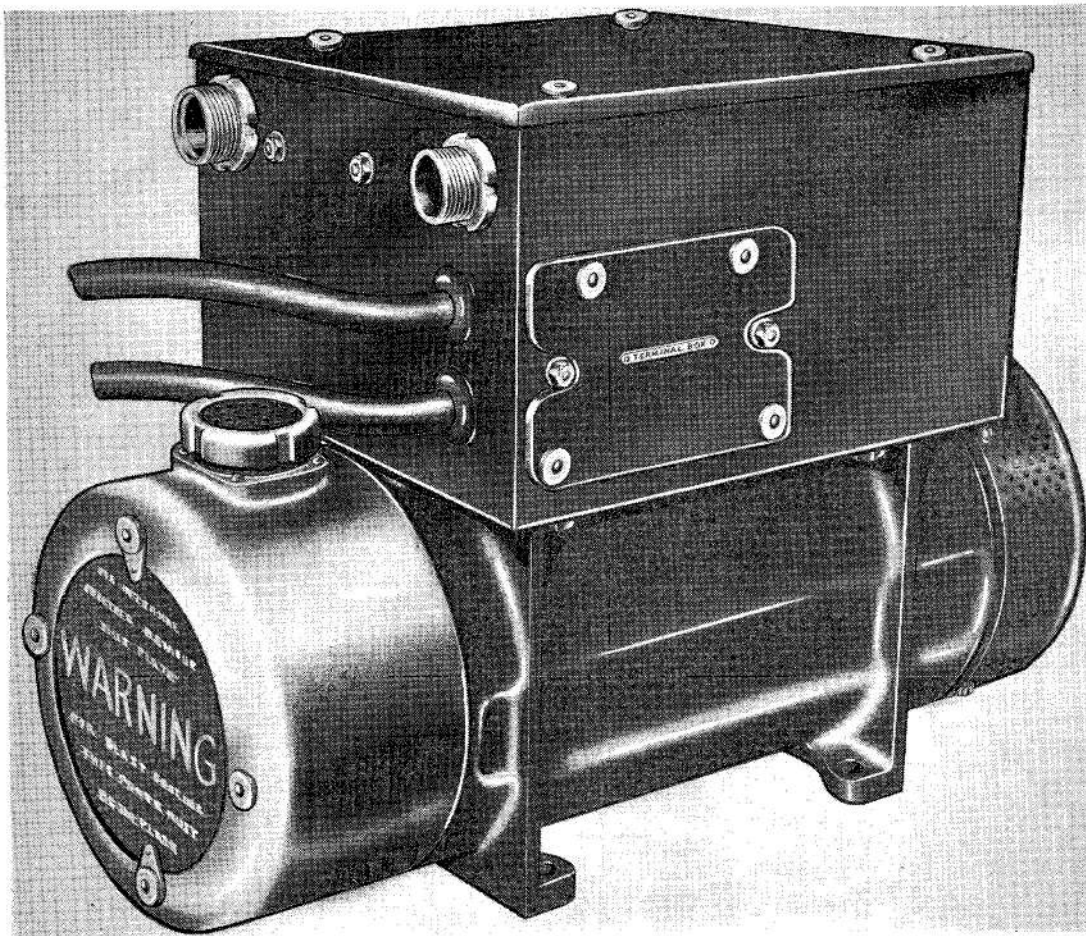

Fig. 1. General view of inverter

RESTRICTED

RESTRICTED

F.S./2

A.P.4343B, Vol. 1, Book 3, Sect. 16, Chap. 9
A.L.39, Feb. 61

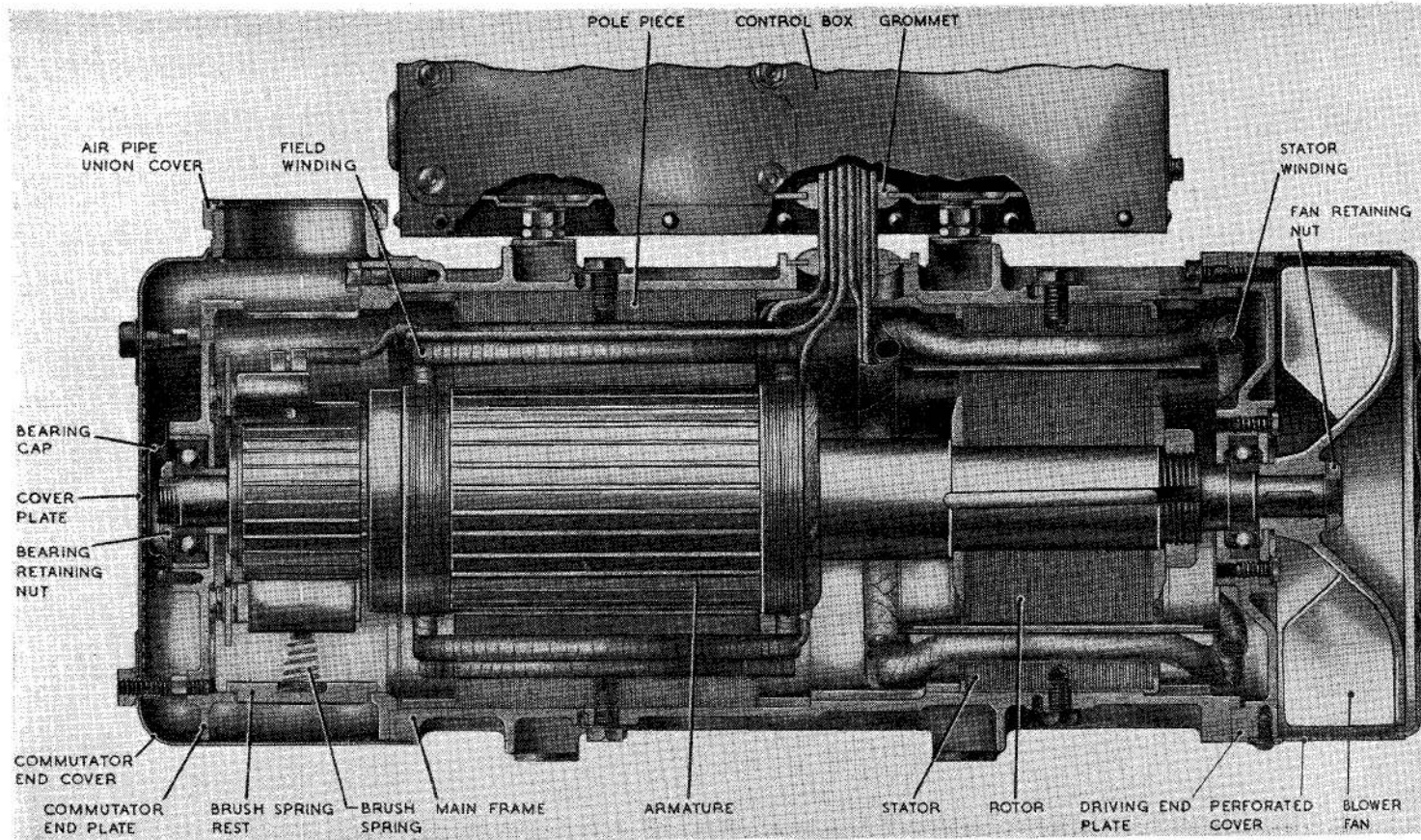

Fig. 2. Sectional view of inverter (Type 201 shown)

to the control box through entries in the inverter main frame and the base plate of the control box, each fitted with a rubber grommet. A sectional view of the inverter is given in fig. 2, and a circuit diagram in fig. 4.

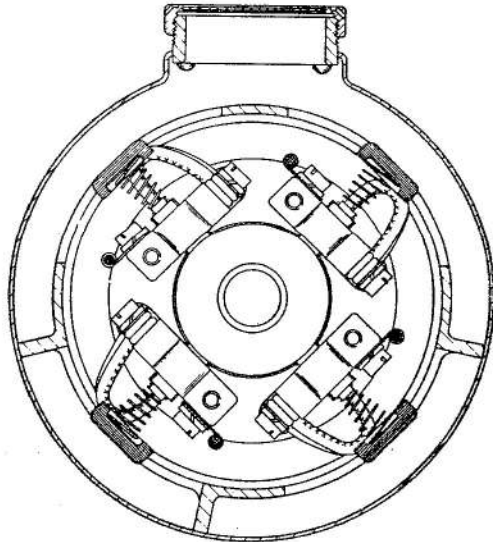

Fig. 3. Sectional view of brushgear (Type 201 shown)

5. The d.c. field system incorporates a four-pole laminated stator carrying the main windings ZZ-Z, the high-impedance regulating field XX-X, and the compensating winding AA-A, which is connected in series with the motor armature. The a.c. stator consists of toothed laminations carrying the main output winding A1-A2, the main

exciting winding X1-X2, and the high-impedance regulating field X3-X4. The motor armature and a.c. rotor are mounted on a common shaft. The armature is of orthodox wave-wound construction, and the rotor consists of toothed laminations which operate with the teeth of the stator to produce the a.c. output.

6. At each end of the main frame is an end plate, each of which houses a grease-lubricated ball bearing in which the main shaft rotates. The commutator end plate carries the brushgear, and is enclosed by the commutator end cover. Brush spring pressure is maintained by coil type springs; these are eccentrically disposed on the spring rests which are fitted across the aperture in the end plate.

Control box

7. The d.c. input enters the control box by two terminals in the terminal box, and passes through a two-leg, single-stage suppressor, Two starting relays are fitted, a magnetic relay switch, Type K (24V) with a 0.075-ohm resistance R3 connected across terminals 3 and 4, and a magnetic relay switch, Type Q1, of which terminals 5 and 6 are not used. R1, a variable resistance of 3 ohms, is connected in series with the main d.c. field ZZ-Z, and R2, a variable resistance of 7 ohms, in series with the main d.c. exciting winding X1-X2. A 9.5 μ F capacitor is connected in series with the main a.c. output winding. The connections from the windings and the 12-way socket are taken to a common terminal block; one side is engraved with letters corresponding to those on the 12-way socket, and the

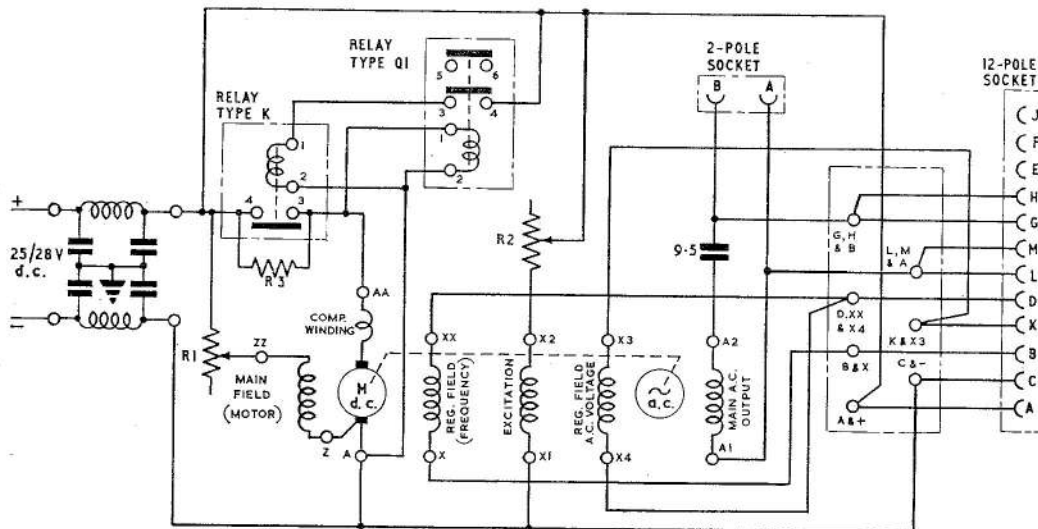

Fig. 4. Circuit diagram (Type 201 shown)

RESTRICTED

other with markings corresponding to those of the windings and the a.c. output socket; in the circuit diagram in fig. 4, the markings relevant to the socket connections are shown first.

Cooling

8. For low altitudes, cooling is effected by a six-bladed fan mounted on the shaft at the a.c. end of the machine. Air is drawn in through a perforated plate in the commutator end cover, passes through the d.c. and a.c. machines, and is expelled radially through perforations in the cover at the a.c. end. The cover plate, shown in fig. 2 outside the perforated plate at the commutator end, must be removed for operating at low altitudes.

Note . . .

Inability to fit the cooling fan at the a.c. end of the inverter shaft has been experienced. Two types of fan exist as follows:—

(a) Ref. No. 5UB/5238 (Drawing No. CX.133150) for inverters post-mod. Elect. B.139.

(b) Ref. No. 5UB/— (Drawing No. CX.107467) for inverters pre-mod. Elect. B.139.

9. For high altitudes, when internal cooling is not sufficient, blast cooling is employed. The cover plate at the commutator end must be in position, and cooling air enters through the air pipe union, passing through the machine and leaving through the perforations at the a.c. end. The commutator end cover can, on installation be rotated and secured in a position 90 deg. in either direction from that shown in fig. 1, thus giving three possible positions for the air pipe union relative to the inverter.

Output control

10. The output voltage and frequency of the inverter is controlled by the electronic regulator Type 2A or 2B.

Functioning

11. The d.c. supply enters the control box via a two-way terminal block and a two-leg, single-stage suppressor. The motor field is energized through rheostat R1. During starting the supply to the motor armature is completed via the current limiting resistance R3, this resistance is connected across the contacts of the relay Type K, the coil of the latter being supplied through contacts 3 and 4 of the relay Type Q1. The coil of the Type Q1

relay is connected across the motor armature; at the instant of switching on the back e.m.f. of the motor is zero and the coil of the Type Q1 relay is virtually de-energized. With increasing motor speed, and consequently back e.m.f., the strength of the Type Q1 coil increases to a point where contacts 3 and 4 close, so energizing and closing the Type K relay. A full d.c. supply is now connected to the armature of the motor.

12. The main field of the a.c. generator is constantly excited from the d.c. supply. The regulating field is connected to the electronic regulator; by this means voltage control of the a.c. output is obtained, by buck-boost excitation of the regulating field. The a.c. voltage is maintained to within ± 1 per cent; the voltage setting is variable over a small range about the normal figure of 115-volts a.c. (r.m.s.), adjustment being obtained by means of the voltage control trimmer on the electronic regulator.

13. If, for any reason, there is a variation in the a.c. output, correction is made by the appropriate section of the electronic regulator. This gives a proportional change in the regulating field current, so correcting the a.c. output voltage. A deviation of about 0.5 per cent in a.c. output is sufficient to cause a complete reversal from maximum boosting to maximum bucking current in the regulating field. Thus the deviation under normal conditions should not be greater than 0.5 per cent.

14. An auxiliary circuit in the electronic regulator facilitates the passing of bucking current through the voltage regulating field during the first 30 seconds whilst the valves of the regulator are warming up. This bucking current reduces the a.c. voltage to about, or just below, the normal figure.

15. The frequency of the a.c. output is utilized in controlling the motor speed; the output is applied to a frequency sensitive circuit which varies the potential applied to the grid of a valve controlling the value and direction of current flowing in the d.c. motor regulating field. Since the valve circuitry is supplied by the a.c. output of the inverter it is essential that the a.c. voltage be accurately regulated.

16. The speed control output circuit of the regulator is similar to that in the voltage section, a buck-boost control of the d.c.

Appendix 2

ROTARY INVERTER, TYPE 201A

LEADING PARTICULARS

Rotary inverter, Type 201A	Ref. No. 5UB/6300
Input	25 to 28-volt d.c.
Output1750 v.a., 115-volt (r.m.s.), Unity p.f., single-phase a.c., 1600 c.p.s. (8000 r.p.m.)
Brush grade K.C.E.G.11	Ref. No. 5UB/6314
Brush spring pressure	39 oz. to 43 oz.
New brush length	25 mm.
Minimum brush length	17 mm.
Rotation (viewed from commutator end)	Clockwise
Overall length	1 ft. 3 $\frac{3}{4}$ in.
Overall width	8 $\frac{1}{4}$ in.
Overall height (including control box)	1 ft. $\frac{1}{8}$ in.
Weight	49 lb. (approx.)
Winding resistance values (at 20 deg. C)—					
Main field (motor) (ZZ-Z)	5.72 ohms
Regulating field (motor) (XX-X)	1700 ohms
Compensating winding (motor) (AA-A)	0.0032 ohms per pole
A.C. output winding (A1-A2)	0.074 ohm
D.C. exciting winding (X1-X2)	8.9 ohms
Regulating field (X3-X4)	1670 ohms
Items in control box—					
Magnetic relay unit, Type T1	Ref. No. 5CW/4620
Magnetic relay switch, Type Q1	Ref. No. 5UB/2007
Resistance R1 (3 ohms)	Ref. No. 5UB/5260
Resistance R2 (7 ohms)	Ref. No. 5UB/5262
Resistance R3 (0.075 ohms)	Ref. No. 5UB/5261
Capacitor (9.5 μ F)	Ref. No. 5UB/5259
Sockets (miniature Mk. 4)—					
A.C. output (2-pole)	Ref. No. 10H/19151
Connection to electronic regulator (12 pole)	Ref. No. 10H/19155

RESTRICTED

Introduction

1. The rotary inverter Type 201A is generally similar to that described and illustrated in the main chapter; the inverter is operated in conjunction with an electronic regulator Type 2A or 2B. Details of the d.c. input and a.c. output are given under Leading Particulars to this appendix. The circuit is similar to that shown in fig. 4 of the main chapter, except that the Type T1 relay is fitted in place of the relay Type K in the control box.

Brushgear

2. Brush spring pressure is maintained by clock-type springs, which supersede the coil-type springs as fitted in the inverter Type 201, the advantage being that longer brushes can be fitted in the inverter Type 201A (*fig. 1*). Improved ventilation for the brushgear, together with interconnected negative brush boxes have been provided to combat low insulation, caused by accumulation of brush dust and grease. The brush springs are not adjustable and should be renewed if outside

the limits specified under Leading Particulars. The minimum permissible brush length will also be found under this heading.

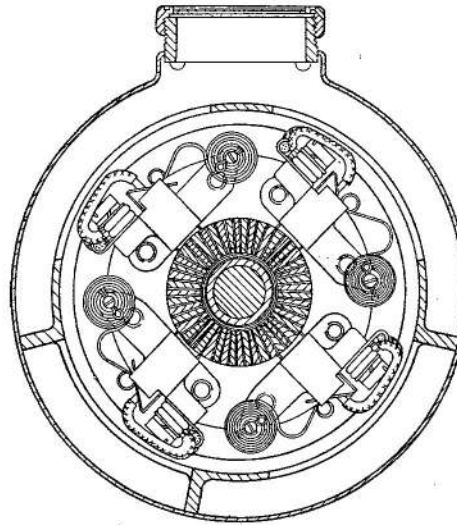

Fig. 1. Sectional view of brushgear

RESTRICTED

Appendix 3

ROTARY INVERTER, TYPE 201B

(Pre Mod. Elect. B467)

LEADING PARTICULARS

Rotary inverter, Type 201B	Ref. No. 5UB/6475
Input	25 to 28-volt d.c.
Output	1750 v.a., 115-volt (r.m.s.), Unity p.f., single-phase a.c., 1600 c.p.s. (8000 r.p.m.)
Brush grade K.C.E.G.11	Ref. No. 5UB/6314
Brush spring pressure 39 oz. to 43 oz.
New brush length 25 mm.
Minimum brush length 17 mm.
Rotation (viewed from commutator end)	Clockwise
Overall length	1 ft. 3 $\frac{3}{4}$ in.
Overall width 8 $\frac{1}{4}$ in.
Overall height (including control box)	1 ft. $\frac{1}{32}$ in.
Weight 49 lb. (approx.)
Winding resistance values (at 20 deg. C)—		
Main field (motor) (ZZ-Z)	5.72 ohms
Regulating field (motor) (XX-X)	1700 ohms
Compensating winding (motor) (AA-A)	0.0032 ohms per pole
A.C. output winding (A1-A2)	0.074 ohm
D.C. exciting winding (X1-X2)	8.9 ohms
Regulating field (X3-X4)	1670 ohms
Items in control box—		
Magnetic relay unit, Type T1	Ref. No. 5CW/4620
Polarized relay unit, Type LAA 10-B7/1 (complete with variable 250 ohm resistance R4)	Ref. No. 5UB/6477
Polarized relay unit, Type LAA 10-B7/1 (without variable resistance R4)	Ref. No. 5UB/6484
Resistance R4 (250 ohms)	Ref. No. 5UB/6485
Resistance R1 (3 ohms)	Ref. No. 5UB/5260
Resistance R2 (7 ohms)	Ref. No. 5UB/5262
Resistance R3 (0.075 ohms)	Ref. No. 5UB/5261
Capacitor (9.5 μ F)	Ref. No. 5UB/5259
Sockets (miniature Mk. 4)—		
A.C. output (2-pole)	Ref. No. 10H/19151
Connection to electronic regulator (12-pole)	Ref. No. 10H/19155

RESTRICTED

Introduction

1. The rotary inverter Type 201B is generally similar to that described in the main chapter; the inverter is operated in conjunction with an electronic regulator Type 2A or 2B. Details of the d.c. input and a.c. output are given under Leading Particulars to this appendix. The circuit (fig. 1) differs from that shown in fig. 4 of the main chapter, the relay Type Q1 is replaced by a relay Type L.A.A.10-B7/1, and the Type K relay is replaced by a relay Type T1.

Functioning

2. The 25 to 28-volt d.c. supply enters the control box via a two-way terminal block and a single-stage, two-leg suppressor; the motor main field is energized through the rheostat R1. During starting the supply to the motor armature is completed via the current limiting resistance R3; this resistance is connected across the contacts of the relay Type T1, the coil of the latter relay being supplied through contacts 3 and 4 of the polarized relay Type L.A.A.10-B7/1. Two differentially wound coils are fitted to the polarized relay; the hold-off coil (terminals 1 and 2) is connected across R3, and the operating coil (terminals TOP and BOTTOM) is connected across the motor armature. At the instant of starting the back e.m.f. of the motor is zero, and the effect of the hold-off coil predominates over the operating coil. With increasing speed and consequently back

e.m.f., the strength of the operating coil will increase to a point where it predominates over the weakening hold-off coil so closing the contacts of the polarized relay and the relay Type T1, a full d.c. supply is now connected to the motor armature. The hold-off coil, now being short-circuited by the contacts of the Type T1 relay, is unable to effect nuisance tripping should the motor speed fall. The variable resistor R4 may be used to adjust the closing of the polarized relay, reference is made to this adjustment in paras. 4 to 8.

Brushgear

3. Brush spring pressure is maintained by clock-type springs, which supersede the coil type springs as fitted in the inverter Type 201, the advantage being that longer brushes can be fitted in the inverter Type 201B (fig. 2). Improved ventilation for the brushgear, together with interconnected negative brush boxes have been provided to combat low insulation caused by accumulation of brush dust and grease. The brush springs are not adjustable and should be renewed if outside the limits specified under Leading Particulars, the minimum permissible brush length will also be found under this heading.

TESTS

Test of machines fitted to aircraft

4. Numerous cases have occurred of the burning out of the starting resistances on the

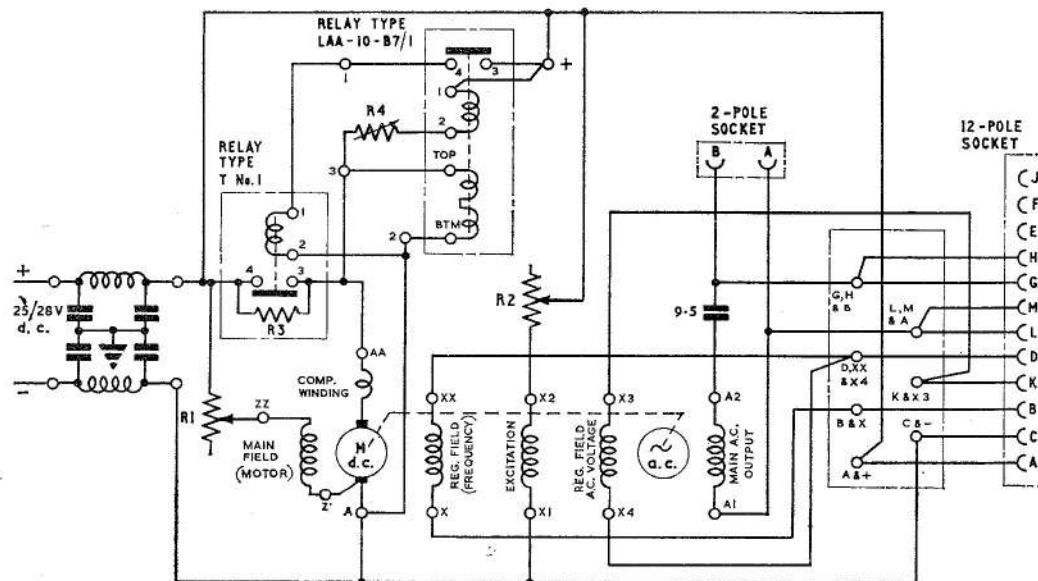

Fig. 1. Circuit diagram

RESTRICTED

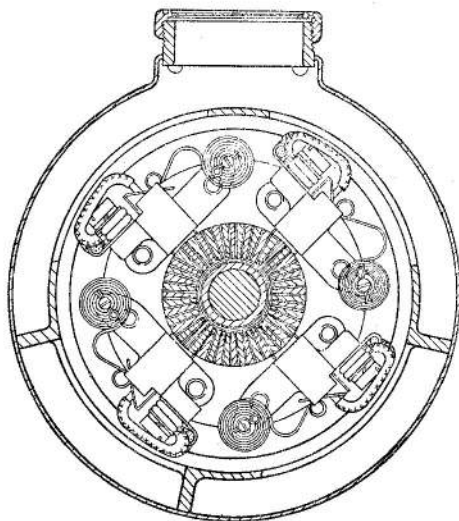

Fig. 2. Sectional view of brushgear

Type 201B Inverter, due to one or more of the following causes:—

- (1) Incorrectly set pilot relay Type L.A.A.10-B7/1.
 - (2) Starting up on load.
 - (3) Starting up on low line volts.
5. To reduce the incidence of this type of failure, the following tests should be carried out:—
- (1) Using a ground power supply of good regulation and capable of providing 300 amperes at 28-volts d.c. start the Inverter on no-load. The starting current at switch ON, should be of the order of 200-300 amperes, and should fall rapidly to approximately 70 amperes as the inverter runs up to speed. There should be a momentary increase in current taken as the pilot and starter relays operate to cut out the starter resistance. The final steady current taken, should not exceed 35 amperes at the machine terminal voltage of 25-volts d.c.
 - (2) Carry out a test as specified in 'Setting of starting circuit' information given below.
 - (3) If there is no evidence of the operation of the starting circuit, the machine is to be switched off immediately and removed for further investigation.

Setting of starting circuit

6. With the variable resistor R4 set at its maximum obtainable value, and, taking care not to physically strain the slider of the adjustable resistor, check that the machine starts and runs up to speed, by bringing the d.c. supply volts up to 28-volts from zero and with the machine on no-load.

7. Restart the machine on the same supply volts, and, reading the input current during the starting period, determine the value of the current immediately before operation of the pilot relay, i.e. at 28-volts d.c. Adjust the variable resistor R4 on the relay unit, so that the input starting current before operation of the pilot relay is between 40 and 90 amperes.

8. With the supply voltage reduced to 25-volts d.c., and the machine running on no-load, switch off the supply and then ensure that the machine will start satisfactorily when switched on again.

Pre-installation and periodical servicing and adjustments

9. Test the starting performance of the complete machine in accordance with para. 30 to 33, if the starting performance does not meet these requirements proceed as follows:—

- (1) Disconnect leads from terminals 1, 2, 3, and +ve of the pilot relay unit.
- (2) Connect a variable voltage (0 to 30-volts d.c.) supply to terminals 3 (+ve) and 2 (-ve).
- (3) Connect a 0 to 30-volts d.c. voltmeter across terminals 1 and 2. This voltmeter is intended to indicate closure of the relay contacts only, and will read, approximately the supply voltage to the unit when the relay contacts are closed.
- (4) Raise the supply voltage and determine the voltage at which the relay contacts close. Reduce the supply voltage and determine the voltage at which the contacts open.
 - (a) Limits are:—
Closing voltage 14 to 17-volts d.c.
Drop-out voltage greater than 1.0 volt d.c.
- (5) If the relay does not meet the limits given in para. 4 above, carefully remove

RESTRICTED

the insulating cover and re-adjust the relay; A.P.4343, Vol. 1, Sect. 11, Chap. 15 refers. On completion of adjustment, refit the cover, using Bostik No. 1297 to affix the four corners only allow 20 minutes to set, and retest to para. 1 to 4 above.

(6) Reconnect the relay in the starter panel and test the starting performance of

the Inverter in accordance with para. 5 to 8.

Insulation resistance test

10. Using a 250-volt insulation resistance tester, measure the insulation resistance between all connection pins, terminals and frame. The insulation resistance value must not be less than 50 000 ohms.

RESTRICTED

Appendix 3A

ROTARY INVERTER, TYPE 201B

(Post Mod. Elect. B467)

Introduction

1. The circuit (fig. 1) differs from that shown in fig. 4 of the main chapter, the Type K relay is replaced by a relay Type T1, and the relay Type Q1, which was formally replaced by a Polarized relay unit (Ref. No. 5UB/6477); is, under the provisions of Mod. No. Elect.B/467, replaced by a Diode controlled relay unit (Ref. No. 5UB/7418). The operating coil of this relay is connected in series with a 560-ohm resistor across which is connected a bank of four series connected Zener diodes.

Functioning

2. The 25-28V d.c. supply enters the control box via a 2-way terminal block and a single-stage, two-leg suppressor; the motor main field winding is energized through the rheostat R1. During starting a supply to the motor armature is completed via the current limiting resistor R3; this resistor is connected across the contacts of the relay Type

T1, supply to the coil of the latter is connected in series with the normally-open contacts of the diode controlled unit. The coil circuit of the latter relay is, in turn, connected across the motor armature as shown in fig. 1.

3. At the instant of starting, the back e.m.f. of the motor is zero, resulting in a small voltage being developed across its armature. During acceleration of the motor, the voltage applied to terminals 2 and 3 of the diode controlled relay unit will steadily increase; however, due to the characteristics of the Zener diode, the operating coil current will remain at a relatively low and constant value until turnover point is reached. At this juncture the coil current will increase sharply, so closing the contacts of the diode controlled relay. A supply to energize and close the Type T1 relay will now be completed so short-circuiting the starter resistor R3, and applying a full potential to the motor armature.

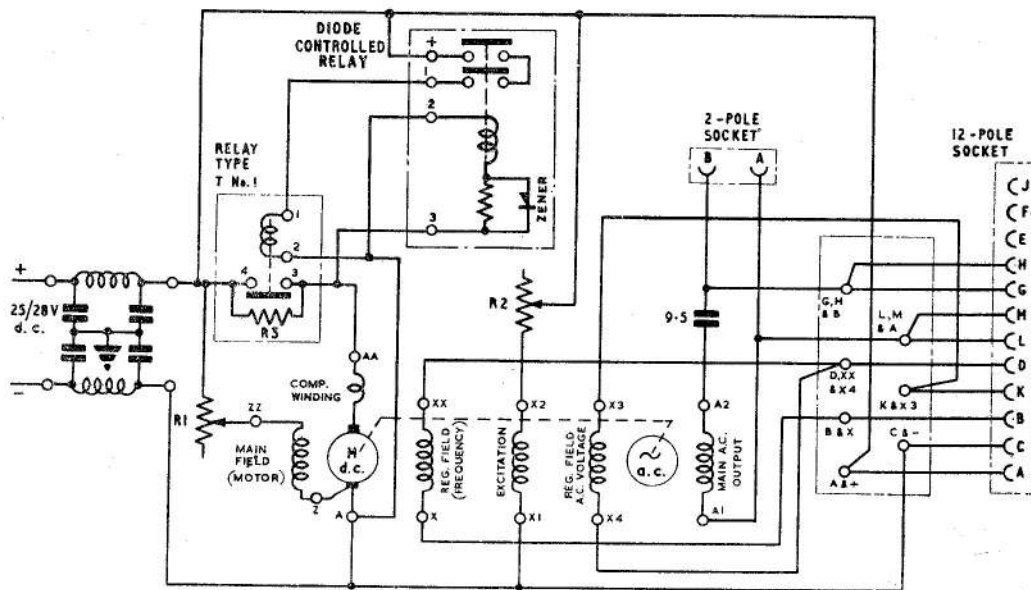

Fig. 1. Circuit diagram

RESTRICTED

TESTING

Test of machines fitted to aircraft

4. Cases have occurred of the burning out of the starting resistances on the Type 201B inverter, due to one or more of the following causes:—

- (1) Starting up on load.
- (2) Starting up on low line volts.

5. To reduce the incidence of this type of failure, the following test should be carried out: using a ground power supply of good regulation and capable of providing 300A at 28V d.c. start the inverter on no-load. The starting current at switch-on, should be of the order of 200-300A, and should fall rapidly to approximately 75A as the inverter runs up to speed. There should be a momentary increase in current taken as the pilot and starter relays operate to cut out the starter resistor. The final steady current taken, should not exceed 35A at the machine terminal voltage of 25V d.c.

Test of diode controlled relay

6. The relay should be insulation tested at 500V as follows:—

- (1) Connect together terminals 2 and 3, test between these terminals and the terminal + and 1.
- (2) Test between terminals + and 1.
- (3) The minimum acceptable value of insulation resistance in (1) and (2) is 50 megohms.

Functional test

7. (1) Connect a d.c. supply, capable of variation between 0 and 30V, in series with a milliammeter having a full scale deflection

of 500mA. Connect this circuit to the relay, positive at terminal 3 and negative at terminal 2. Two 30V range voltmeters must now be connected in the circuit, one across terminals 2 and 3, and the other across the 560 ohm resistor, to measure Zener voltage. Connect a warning lamp supplied by a 28V d.c. source between terminals + and 1.

(2) Conduct the following tests and ensure that the meter indications are within the specified range.

(a) Raise the supply voltage from 0 volts and note the supply voltage and input current at which the contacts close. The voltage should be within the limits of 18 and 22.5V, and the input current must not exceed 85 mA.

(b) Raise the supply voltage to 28V, reduce it steadily and note the supply voltage and input current at which the contacts open. The voltage should be within the limits of 3 and 14V, and the input current must not exceed 28 mA.

(c) Take readings of input current and Zener voltage at the supply voltages specified below:—

Supply voltage	Input current (test limits)	Zener voltage (test limits)
29V	150-250mA	18.8-21.2V
24V	75-155mA	17.5-20.2V

Inverter insulation resistance test

8. Using a 250V insulation resistance tester, measure the insulation resistance between all connection pins, terminals and frame. The insulation resistance value must not be less than 50,000 ohms.

RESTRICTED

This file was downloaded
from the RTFM Library.
Link: www.scottbouch.com/rtfm
Please see site for usage terms,
and more aircraft documents.

