

Chapter 2

ROTARY INVERTER, TYPE 153A (ROTAX S3107/1)

LIST OF CONTENTS

	<i>Para.</i>		<i>Para.</i>
<i>Introduction</i>	1	<i>Servicing</i>	5
Description	3		

LIST OF ILLUSTRATIONS

	<i>Fig.</i>		<i>Fig.</i>
<i>Sectional view of Type 153A inverter</i> ...	1	<i>Diagram of internal connections...</i> ...	2

LEADING PARTICULARS

Inverter, Type 153A	<i>Ref. No. 5UB/6730</i>
<i>Input</i>	100 to 116V d.c., 14 amp.
<i>Output</i>	115V, 3-phase, a.c., 4.7 amp., 400 c/s
<i>Rating</i>	<i>Continuous</i>
<i>Speed</i>	8,000 r.p.m.
<i>Rotation (viewed from commutator end)</i> ...	<i>Clockwise</i>
<i>Maximum operational altitude</i>	50,000 ft. (<i>fan and blast cooled</i>)
<i>Operative temperature range</i>	-55 deg. C to +50 deg. C
<i>Output connection (4-pole Mk. 4 miniature plug)</i>	<i>Ref. No. 10H/9560310</i>
<i>Control panel interconnection (12-pole Mk. 4 miniature plug)</i>	<i>Ref. No. 10H/9560150</i>
<i>Brush grade—</i>	
<i>d.c. input</i>	<i>F2C (Ref. No. 5UB/6729)</i>
<i>a.c. output</i>	<i>KC.CM6 (Ref. No. 5UB/6486)</i>
<i>Brush spring pressure—</i>	
<i>d.c. input</i>	15.5 to 17 oz.
<i>a.c. output</i>	4 to 5 oz.
<i>Minimum brush length—</i>	
<i>d.c. input</i>	0.375 in.
<i>a.c. output</i>	0.375 in.
<i>Weight</i> 30 lb.

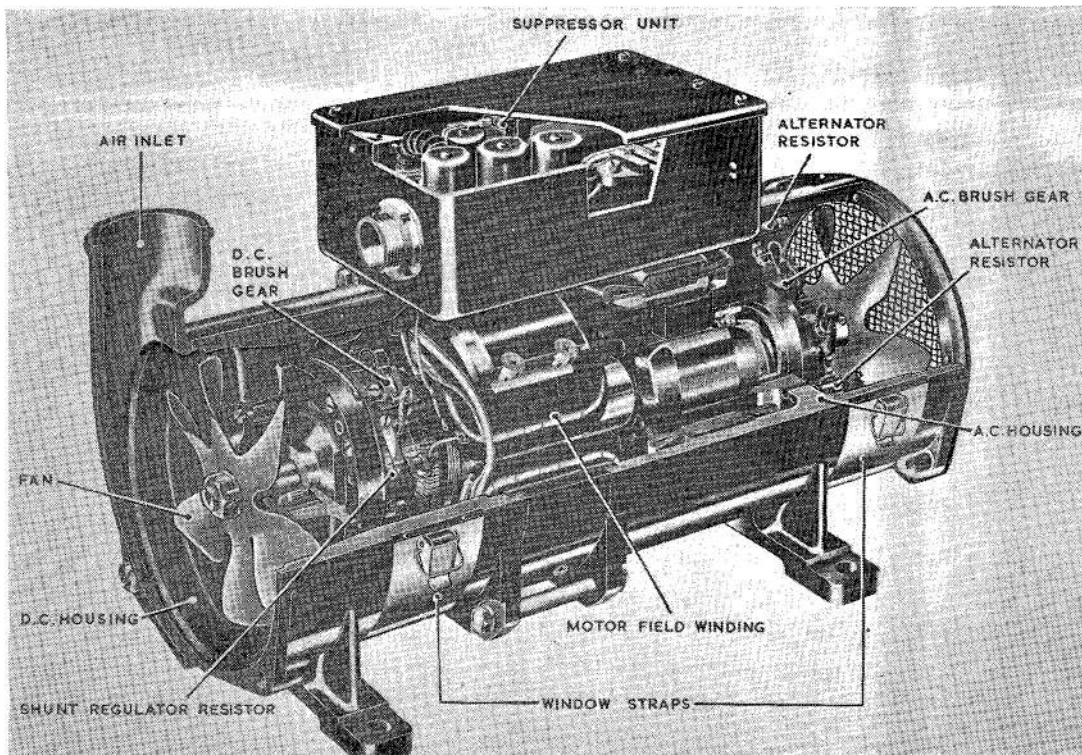

Fig. 1. Sectional view of Type 153A inverter

Introduction

1. The Type 153A inverter is used in conjunction with the control panel, Type 19, or with panels Type 19 and 25, to provide certain aircraft instruments and equipment with an a.c. supply at a controlled voltage and frequency. With 100 to 116 volts applied to the d.c. end of the machine, the rotor speed is maintained at 8,000 r.p.m. \pm 2 per cent and the a.c. output at 400 c/s \pm 2 per cent.

2. The machine is continuously rated, giving a 3-phase, 115-volt a.c., 750-watt output at 0.9 leading to 0.8 lagging power factor, when supplied with a d.c. input of 100 to 116 volts. The design of the machine is, however, such as to meet a 1 kW pulsating load requirement for radar equipment.

DESCRIPTION

3. A general description of inverters in the S3100 series will be found in A.P.4343, Vol. 1, Sect. 8, Chap. 2, App. 1. The Type 153A inverter (*fig. 1*) follows the same general construction, but has two shunt field ballast resistors mounted on the brush gear and four rotor circuit resistors mounted in the a.c. housing. It differs from the Type 153 inverter in having a separate shunt field input connection to give increased starting torque, the connection being an additional terminal inside the suppressor box.

4. The electrical output connection is made by a 4-pole Mk. 4 miniature plug, and the interconnection between the inverter and its associated panel(s) via a 12-pole Mk. 4 miniature plug, both located on the suppressor box.

RESTRICTED

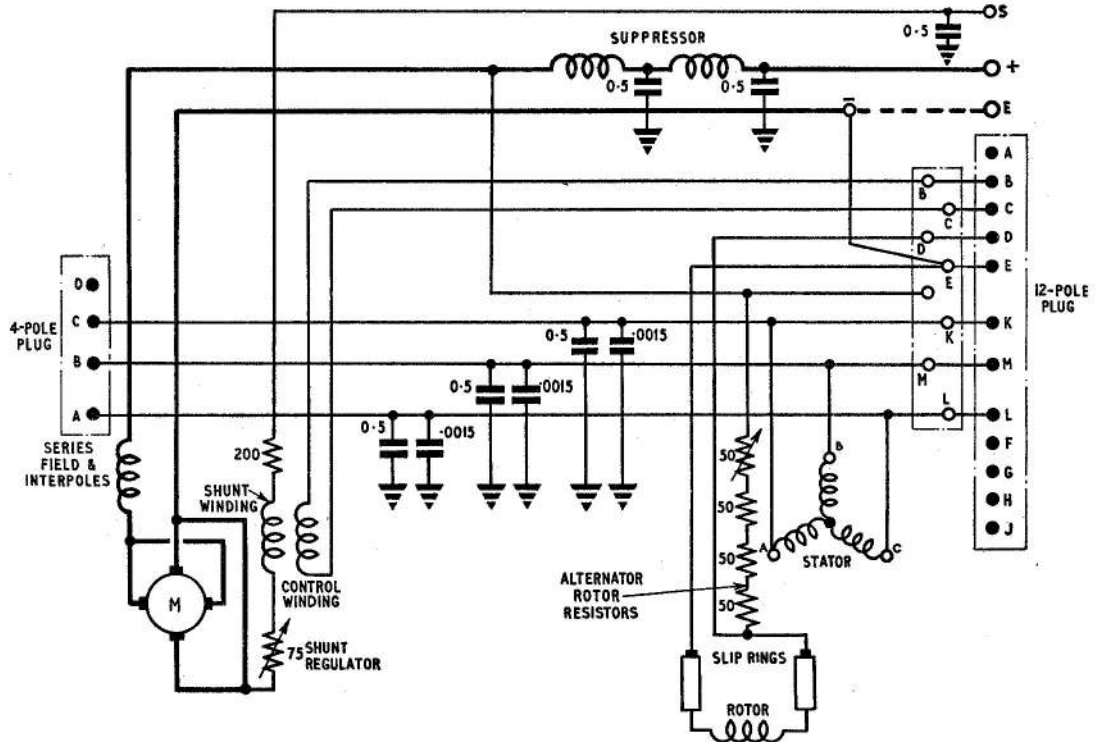

Fig. 2. Diagram of internal connections

SERVICING

5. Servicing is as given for S3100 inverters in A.P.4343, Vol. 1, Sect. 8, Chap. 2, App. 1.

Details of brush spring pressure and minimum brush lengths are given under Leading Particulars.

This file was downloaded
from the RTFM Library.

Link: www.scottbouch.com/rtfm

Please see site for usage terms,
and more aircraft documents.

