

Chapter 14**TWIN TRANSFORMER-RECTIFIER UNIT, ROTAX, TYPE U8301****LIST OF CONTENTS**

	Para.		Para.
<i>Introduction</i>	1	<i>Overheat switch</i>	9
Description	2	<i>Failure indication</i>	10
<i>Electrical connections</i>	4	<i>D.C. contactor</i>	11
<i>Operation</i>	5	<i>A.C. contactor</i>	12
<i>Control system</i>	6	Installation	13
<i>Protection system</i>	7	Servicing	14
<i>Reverse current protection</i>	8	<i>Testing</i>	16

LIST OF ILLUSTRATIONS

	Fig.		Fig.
<i>General view of unit</i>	1	<i>Circuit diagram of complete unit</i>	3
<i>Basic circuit diagram of T.R.U. channel</i>	2		

LIST OF TABLES

	Table
<i>Terminal connections</i>	1
<i>Components of unit</i>	2

LIST OF APPENDICES

	App.
<i>Standard serviceability test for T.R.U., Type U8301 (to be issued later)</i>	A

LEADING PARTICULARS

Transformer-rectifier unit, Type U8301	<i>Ref. No.</i>
<i>Output</i>	28V d.c., 85 amp.
<i>Rating</i>	Continuous
<i>Input voltage</i>	204V \pm 4V, 3-phase, 335-485 c/s
<i>Input current</i>	One channel operating: 7.5A both channels operating: 3.75 A each approx.
<i>Maximum altitude</i>	36,000 ft.
<i>Cooling</i>	Integral blower
<i>Dimensions—</i>	
<i>Length, overall</i>	22.4 in. (including locating pins)
<i>Width, overall</i>	7.5 in.
<i>Height, overall</i>	7.75 in.
<i>Weight</i>	43.75 lb.

RESTRICTED

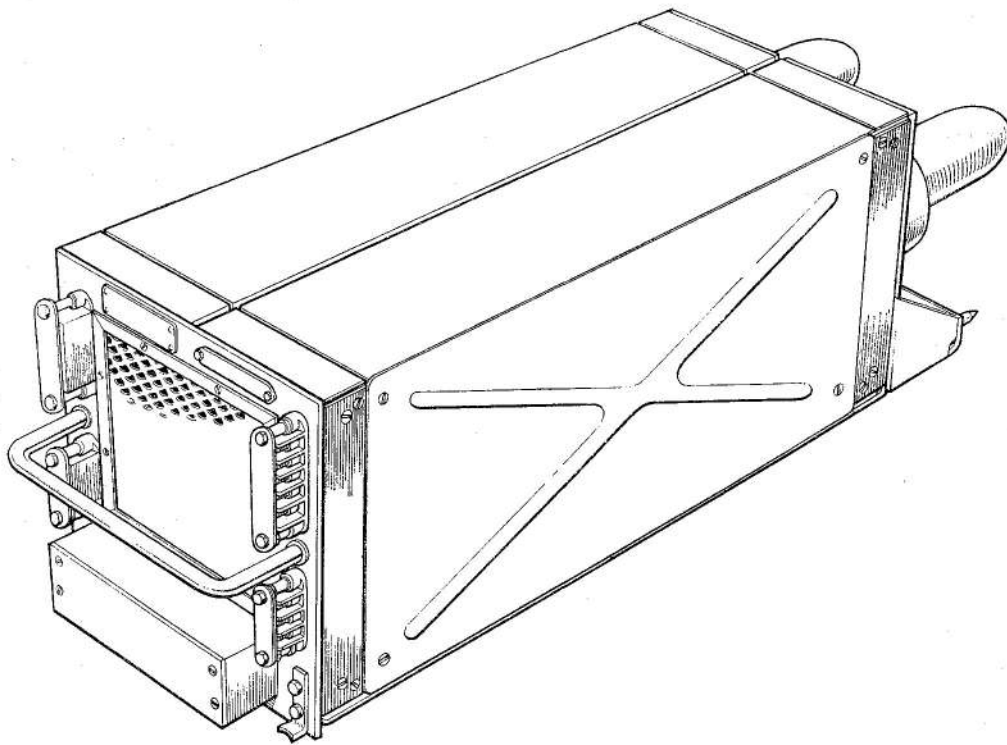

Fig. 1. General view of unit

Introduction

1. The twin transformer-rectifier unit, Type U8301, is designed to provide a d.c. supply of 28 volts at 85 amp. from an alternator input of 200 V., 400 c/s. Its specific function is to power one channel of the 'Autoland' equipment on the Short 'Belfast'.

DESCRIPTION

2. The unit consists of two identical but independent transformer-rectifier assemblies in one case, with their outputs paralleled at the output terminals. The inputs are fed from separate alternators (Rotax Type BA2003) which may generate at different voltages and frequencies. The rated output is obtainable whether either T.R.U. is operating singly, or both of them at once; in the latter case the a.c. input current through the transformer primaries is halved. A number of control and protection devices are incorporated so that in the event of failure of either alternator, or a fault in either T.R.U., continuity of specified performance is assured.

Each T.R.U. channel is cooled by its own axial blower, self-powered from the d.c. output and therefore started and stopped automatically.

3. Within a case conforming to the A.T.R. system as laid down in Specification A.R.I.N.C. No. 404, the components of the two channels are symmetrically disposed on both sides of a central bulkhead. The two assemblies are identical, except for capacitors C14, C10, C11, C12 and C13 which are common to the output of both channels. The top and side panels are attached to the case frame by 4 B.A. countersunk screws and are easily removed when it is required to gain access to the components for testing or servicing.

Electrical connections

4. External connections are brought out to moulded terminal blocks on the front panel of the unit, as listed in Table 1. All terminal blocks are provided with covers.

RESTRICTED

TABLE 1
TERMINAL CONNECTIONS

<i>Terminals</i>	<i>Marking</i>	<i>Type of terminal</i>
A.C. input	A, B, C	Ward Brooke 3-way block
A.C. input	A1, B1, C1	Ward Brooke 3-way block
D.C. outout	L+ve	0.25 in. UNF stud
D.C. output	L-ve	0.25 in. UNF stud
D.C. output	A UX	10-32 UNF stud
Associated equipment	W, S, N	Ward Brooke 5-way block
Associated equipment	W1, S1, N1	Ward Brooke 5-way block
Trip test	T	Ward Brooke 5-way block

Operation

5. A simplified diagram of the basic T.R.U. circuit is given in Fig. 2. The 3-phase input is stepped down by the transformer TR5 and rectified by six silicon diodes to give 28 V d.c. at the line output terminals with an output current of 85 A. The 1200 μ F electrolytic capacitor C14 is connected across the output terminals, which are common to both channels. Insulation tests should not therefore be made between terminals line + and - or frame without first disconnecting this capacitor.

Control system

6. The unit is switched into or out of operation by a switch in the voltage control and protection unit, Type U6401. When this switch is closed, a 28 V d.c. supply, connected via terminals S and N, supplies power via contacts on RL3 to the coil of the a.c. con-

tactor RL1 and closes contacts which complete the a.c. input circuit. A signal voltage is then taken from the secondary of the main transformer, via the diodes MR7, MR8, MR9 (fig. 3), and a second pair of contacts on RL3, to energize the coil of the d.c. contactor RL2, thus completing the d.c. output line circuit. When this d.c. contactor closes, one pair of contacts connects power to a remote failure indicator via terminal W.

Protection system

7. The following description of operation should be read in conjunction with the complete unit circuit diagram (fig. 3). The protection system is based upon a 25 per cent change in input/output current balance tripping input and output contactors, D.C. reverse current and overheat protection are also incorporated in the above, as will be described later. Three current transformers,

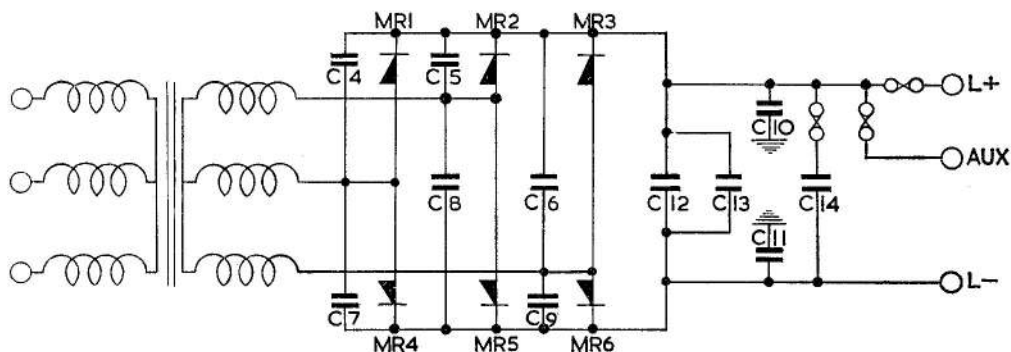

Fig. 2. Basic diagram of T.R.U. channel

RESTRICTED

TR1, TR2 and TR3, in the input lines, together with three bridge diodes D1-D6, provide a current proportional to the average of the three input line currents. This is used to feed a control winding on a toroidal transducer, TD1. A second control winding consisting of a single turn in opposite magnetic sense to the first is connected in the main d.c. output line. The ampere-turns ratio between the two windings is such that, when the input-output currents are balanced, the a.c. windings of TD1 present a high impedance to the secondary of TR4 and a minimum voltage appears across R5. A uni-junction transistor, UT1, is connected in the coil circuit of relay RL3. The emitter of UT1 derives its voltage from R5, via rectifiers MR2, while the voltage on its two bases is effectively that set by the zener diode RD1. In the balanced condition the emitter voltage will be less than the base voltage and UT1 will not conduct. When unbalance occurs, due to a fault, the impedance of TD1 falls steeply and the voltage across R5 is increased. This voltage is rectified and an increased potential is applied to the emitter of UT1, causing it to conduct. Thus switched "on", it passes current through the coil of relay RL3, which breaks the circuits feeding the a.c. input and d.c. output contactors and at the same time breaks the circuit to the failure indicator.

Reverse current protection

8. Because the d.c. output current of the unit passes through a control winding on TD1, any such fault as reverse current from an external source will upset the balanced condition and trip the contactors as described above.

Overheat switch

9. Overheat protection takes the form of a pre-set thermostatic switch, normally open, mounted directly on the heat sink and connected in parallel with the transducer TD1. Overheating short-circuits the transducer, upsets the input-output current balance and thus causes the contactors to trip.

Failure indication

10. When the d.c. contactor is tripped, one pair of normally closed contacts opens and breaks the supply to a remote failure indicator (terminal W), thereby giving warning of the failure.

D.C. contactor

11. The Rotax Type D11805 contactor contains a pair of heavy current main contacts, closed by a solenoid in normal operation, and two micro-switches, one normally open and one normally closed. Of the latter only the normally closed micro-switch is used in this case, connected as described in para. 10 above.

A.C. contactor

12. The Rotax Type D6321 contactor is a simple 3-way circuit breaker in which three pairs of contacts mounted on an armature are normally held closed by the passage of d.c. through a pair of electromagnet coils. The 28V supply which energizes these coils when the unit is in operation is obtained externally via terminals S and N, or S1 and N1, as described in para. 6.

INSTALLATION

13. The unit is constructed for assembly in a standard rack based on A.R.I.N.C. size 3/4 A.T.R. long, incorporated in the aircraft for which it is designed. It should be slid into position until the rear holding down pins engage, and locked by means of the two front mounting feet spaced 6.75 in. apart. Electrical connections can then be made to the terminal blocks as described in para. 4 and Table 1.

SERVICING

14. Make a visual examination of the unit to ensure that it has not sustained any physical damage and that all terminals and connections are secure, clean and free from corrosion.

15. Remove the screws securing the top cover panels and make a visual examination of the internal components to ensure that there are no signs of damage or overheating and that electrical connections are secure.

Testing

16. If at any time the serviceability of the unit should be suspect, tests may be applied in accordance with Appendix A.

RESTRICTED

TABLE 2
COMPONENTS OF UNIT

<i>Component</i>	<i>Circuit Reference</i>	<i>Value or rating</i>	<i>Rotax Code</i>
A.C. contactor	RL1		D6321
D.C. contactor	RL2		D11805
Overheat switch	SW1	150 deg. C	N168633
Positive diode assembly	MR1-2-3		N154420-2
Negative diode assembly	MR4-5-6		N154420-1
Main Transformer	TR5		P15501
Protection transductor	TD1		P13203
Protection unit			F9201
Capacitor, T.R.U. unit	C12, C13	2 μ F	N159165/6
Capacitor, T.R.U. unit	C10, C11	0.1 μ F	N163084
Capacitor, T.R.U. unit	C14	1200 μ F	N163037
Capacitor, T.R.U. unit	C1, C2, C3	1 μ F	N159165-11
Capacitor, T.R.U. unit	C4, C5, C6, C7, C8, C9	1 μ F	N159165-6
Capacitor, F9201 unit	C1	250 μ F, 15 V	N140828-2
Capacitor, F9201 unit	C2	140 μ F	N140828/1
Transistor, F9201 unit	UT1	2 N.491 Uni-junction	N151013-3
Zener diode, F9201 unit	RD1	SZ 18C, 18 V	N151056-7
Relay, F9201 unit	RL3	13 V	N161959-4
Diode, F9201 unit	D1, D2, D3, D4, D5, D6, D7, D8, D9, D10, D11	CV.7040	N151049
Resistor, F9201 unit	R1	3.9 K Ω , 1.5 W	N113590/63
Resistor, F9201 unit	R2	390 Ω 1.5 W	N113590/39
Resistor, F9201 unit	R3	330 Ω , 1.5 W	N113590/37
Resistor, F9201 unit	R4	1.1 K Ω , 1.5 W	N113590/50
Resistor, F9201 unit	R5	270 Ω , 1.5 W	N162087-35
Fuse, main line +ve		100 A	N164427
Fuse, Aux., +ve		20 A	N164428
Fuse, C14 +ve		7 A	N 131463-7
Fuse, RL2		0.25A	N154765-1
Fuse, Blower, F1, F3		1A	N154765-3

RESTRICTED

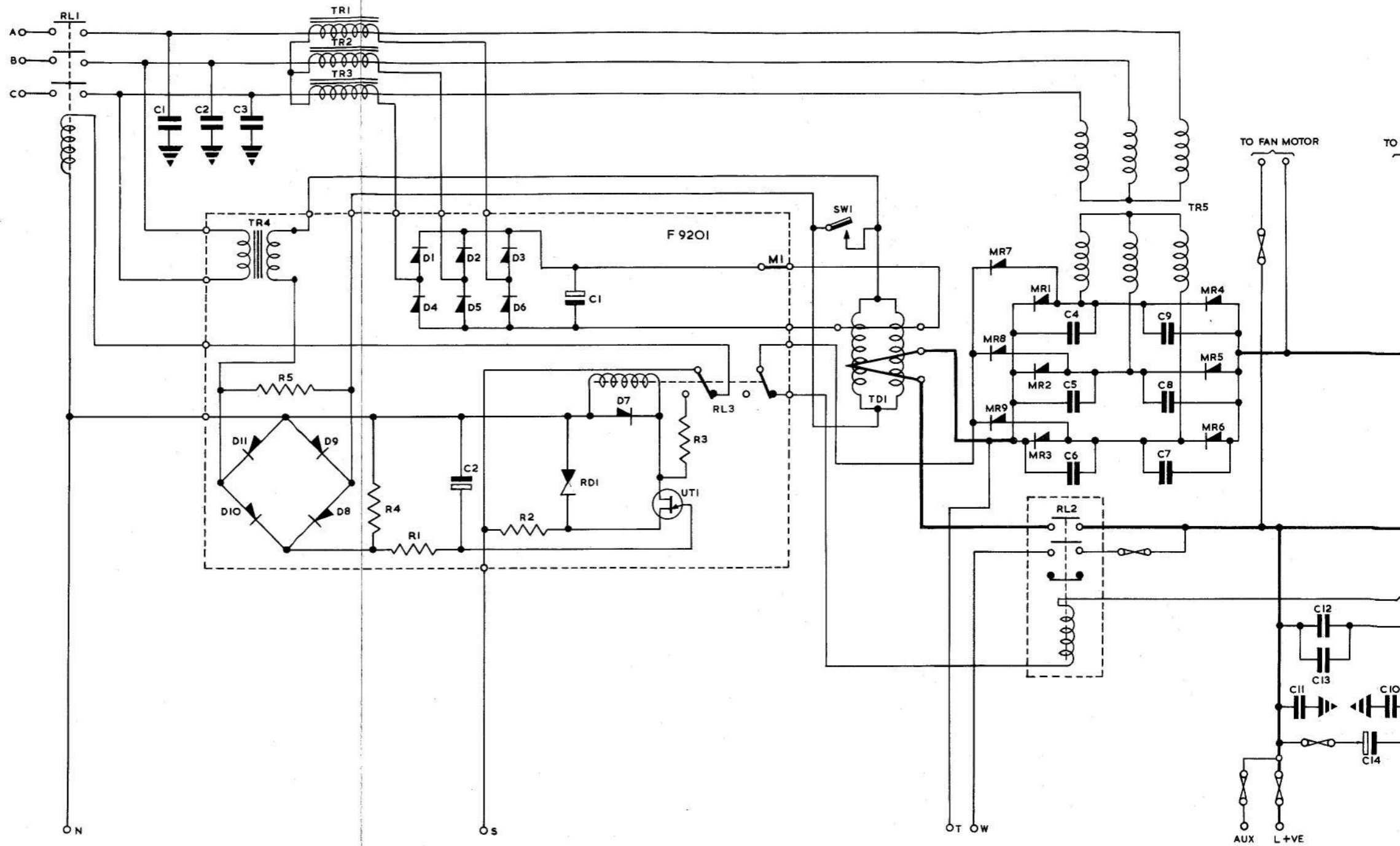
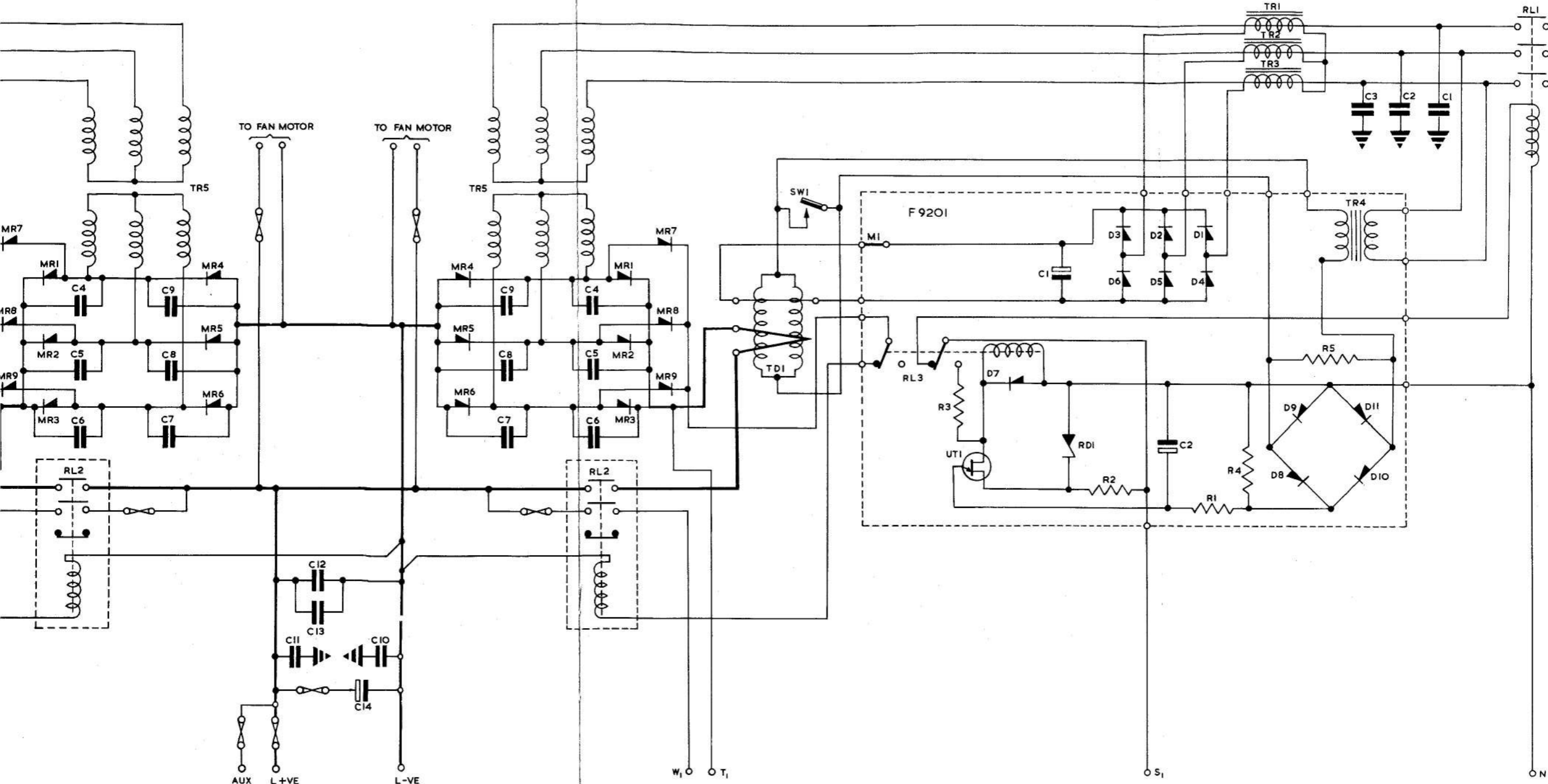

Fig.3

1231/370201/16/9/63 J. T. & S.

Circuit diagram of con
RESTRICTED



Circuit diagram of complete unit
RESTRICTED

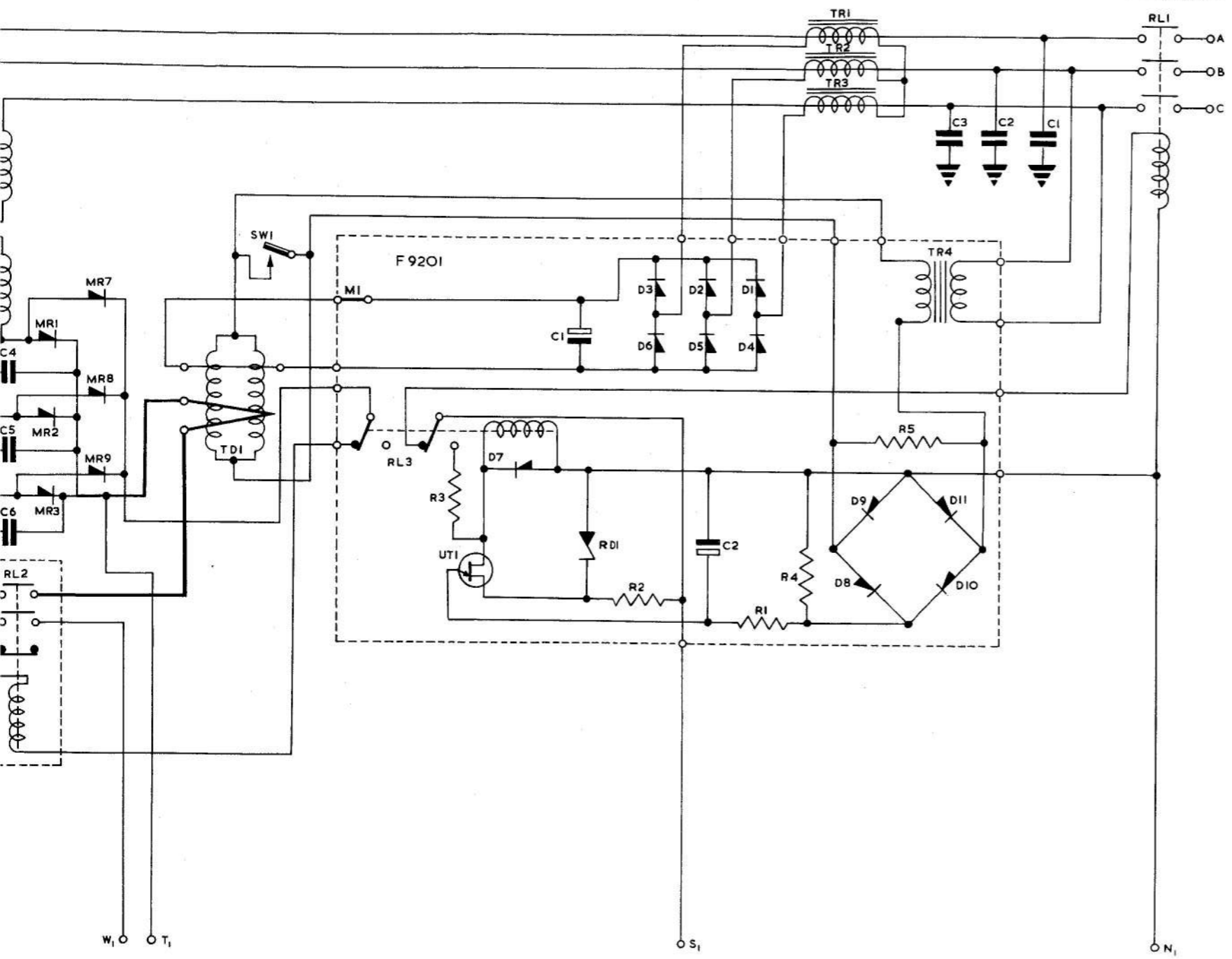

Fig.3

This file was downloaded
from the RTFM Library.

Link: www.scottbouch.com/rtfm

Please see site for usage terms,
and more aircraft documents.

