

**Chapter 26****TRANSFORMERS, ROTAX, P2400 SERIES****LIST OF CONTENTS**

	<i>Para.</i>		<i>Para.</i>
<i>Introduction</i> ....	1	<i>Electrical connections</i> ....	6
<b>Description</b> ....	3	<b>Servicing</b> ....	7
<b>Installation</b> ....	5	<i>Insulation resistance test</i> ....	8

**LIST OF ILLUSTRATIONS**

	<i>Fig.</i>
<i>General view of typical transformer</i> ....	1

**LIST OF APPENDICES**

	<i>App.</i>
<i>Windscreen heating transformer, Rotax, Type P2401/1</i> ....	1
<i>Tail de-icing transformer, Rotax, Type P2402/1</i> ....	2
<i>De-icing transformer, Rotax, Type P2403</i> ....	3

**RESTRICTED**

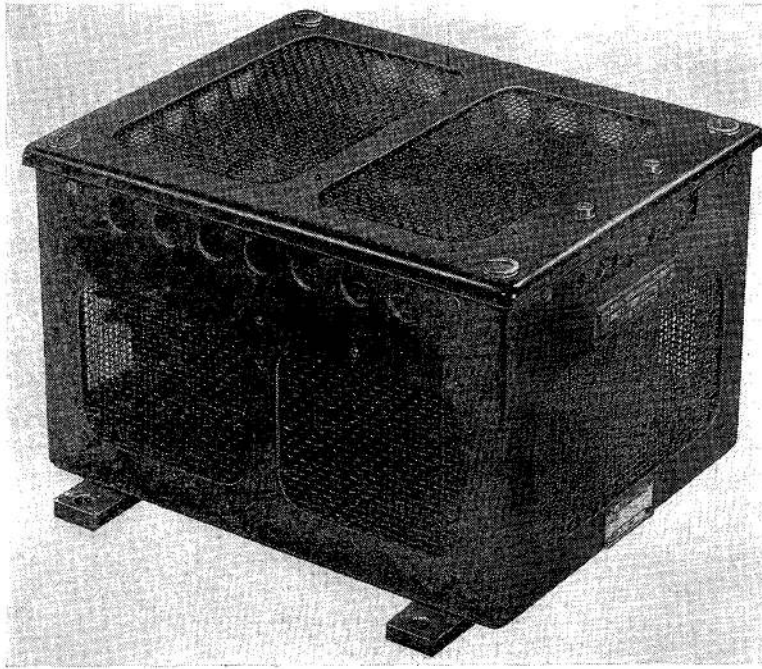

Fig. 1. General view of typical transformer

#### Introduction

1. The transformers (*fig. 1*) are designed to operate in aircraft where there is a 3-phase, 400 c/s supply of 200 volts.
2. The three-phase windings are auto-star-connected and tapped for various voltages. Windscreen heating tappings are provided for inlet and outlet voltages; these are given in the relevant Appendix of the series.

#### DESCRIPTION

3. The unit consists of an aluminium box containing a core type auto-transformer designed with a steel frame, three limb crystalloy laminated yoke, cylindrical coil, and a terminal board mounted on a raised tier.
4. The transformer is designed for natural cooling, and the unit should not be mounted closer than 1.000 in. to any blanking surface. The flow of air over heating surfaces produced by natural convection passes through ventilating holes and gauze covered apertures in the box.

#### INSTALLATION

5. The outside dimensions of the unit are given under Leading Particulars in the

relevant Appendix, and four 0.281 in. diameter fixing holes at  $6.750 \times 5.500$  in. centres are provided on two brackets attached to the base.

#### Electrical connections

6. Cable entry is by means of a clamp situated at one end of the box. Connections are made via 2 BA terminals attached to a board inside the box, details of which will be given in the relevant Appendix of the series.

#### SERVICING

7. Assuming that the unit has been correctly installed and operated, servicing will normally be restricted to visual inspection for freedom from damage and security of connections. Should the operation of the transformer be suspect, it may be tested in accordance with the information given under Testing in the relevant Appendix.

#### Insulation resistance test

8. The insulation resistance should be measured with a 250 volt insulation resistance tester between all terminals and the frame, and should not be less than 50,000 ohms.

RESTRICTED

## Appendix 1

### WINDSCREEN HEATING TRANSFORMER, ROTAX, TYPE P2401/1

#### LEADING PARTICULARS

Transformer, Type P2401/1	....	....	....	....	Ref No.
Input (3-phase, 400 c/s)	....	....	....	....	200V a.c.
Output	....	....	....	....	170, 254, 317V a.c.
Current	....	....	....	....	12.2A
Power output	....	....	....	....	6.65 kVA
Air temperature range—					
At 1/3 full load	....	....	....	....	-65 deg. C to +45 deg. C
At full load	....	....	....	....	-65 deg. C to +20 deg. C
Altitude ceiling	....	....	....	....	50,000 ft
Overall dimensions—					
Length	....	....	....	....	7.750 in.
Width	....	....	....	....	7.250 in.
Height	....	....	....	....	5.222 in.
Weight	....	....	....	....	15.2 lb.

1. The P2401/1 transformer is identical with that described and illustrated in the main chapter; the transformer connections and voltages are shown in the circuit diagram (fig. 1).

2. Electrical connections for the P2401/1 transformer are as follows:—

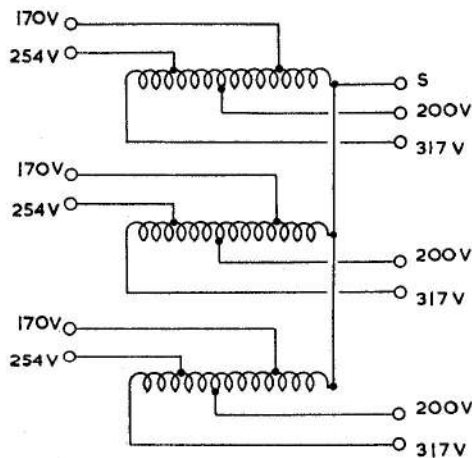

Fig. 1. Diagram of internal connections

Input to terminals marked 200V.

Output from terminals marked 170, 254 and 317V.

Star point terminal marked 'S'.

3. Installation is by four 0.281 in. diameter fixing holes at 6.750 x 5.500 in. centres, located in two brackets attached to the base. The transformer is naturally cooled and should not be mounted closer than one inch to any blanking surface.

#### Testing

4. *Resistance check.*—(1) Connect a d.c. supply, via a suitable resistance, between the S terminal and each of the three terminals marked 317, in turn.

(2) In each case, a constant current of 10 amp. should be maintained for 5 minutes.

(3) Voltage measurements, between the terminals of the phase in which the current is flowing, should be as follows:—

Between S and 170 the voltage should be 2.06 to 2.2 volts.

Between 170 and 200 the voltage should be 0.305 to 0.345 volt.

RESTRICTED

Between 200 and 254 the voltage should be 0.365 to 0.396 volt.

Between 254 and 317 the voltage should be 0.42 to 0.45 volt.

(4) Disconnect the d.c. supply from the transformer.

5. *Open circuit test.*—(1) Connect terminals 200 to a 3-phase, 400 c/s variable voltage supply. The circuit should be suitably metered to measure the input volts, amperes and watts.

(2) Adjust the line voltage to an average value of 200 volts and keep constant.

(3) The average values of the primary line currents should not exceed 0.110 amp. and the difference between individual line currents should not be greater than 0.04 amp.

(4) The total power input should not exceed 30 watts.

(5) The individual voltages of each of the three output supplies should lie between:—

Output No. 1: 174 and 178 volts

„ No. 260 and 267 volts

„ No. 3: 325 and 332 volts

6. *Short circuit test.*—(1) Connect terminals 200 to a 3-phase, 400 c/s variable voltage supply. The circuit should be suitably metered to measure the input volts, amperes and watts.

(2) Short circuit the terminals of output No. 3 (i.e. terminals marked 317), together, via a set of three current measuring instruments.

(3) Increase the applied voltage until the mean value of the output No. 3 currents is 19.5 amp.

(4) The average value of the input currents should lie between the values of 32.0 and 34.0 amp.

(5) The total power (cold) should not exceed 235 watts.

(6) Maintain the short circuit conditions for at least 5 minutes, after which the total input watts should be taken again.

(7) The total power input watts (hot) should not increase by more than 35 watts above the “cold” condition.

7. *Insulation resistance test.*—The resistance between terminal S and the frame should not be less than 50,000 ohms using a 250-volt insulation resistance tester.

**RESTRICTED**

## Appendix 2

### TAIL DE-ICING TRANSFORMER, ROTAX, TYPE P2402/1

#### LEADING PARTICULARS

Transformer, Type P2402/1	....	....	....	....	Ref. No.
Input (3-phase, 400 c/s)	....	....	....	....	200V a.c.
Output	....	....	....	....	160, 180, 220, 240V a.c.
Current	....	....	....	....	39.2A
Power output	....	....	....	....	16.3 kVA
<i>Air temperature range</i>					
At 1/3 full load	....	....	....	....	-65 deg. C to +45 deg. C
At full load	....	....	....	....	-65 deg. C to +20 deg. C
Altitude ceiling	....	....	....	....	50,000 ft.
<i>Overall dimensions—</i>					
Length	....	....	....	....	7.750 in.
Width	....	....	....	....	7.250 in.
Height	....	....	....	....	5.597 in.
Weight	....	....	....	....	17.6 lb.

1. The P2402/1 transformer is identical with that described and illustrated in the main chapter, except for different transformer output voltages, as shown in fig. 1.

2. Electrical connections for the P2402/1 transformer are as follows:—

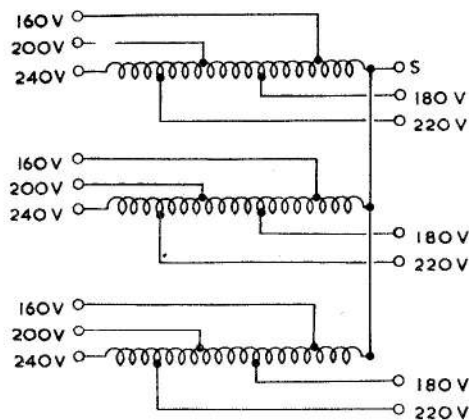

Fig. 1. Diagram of internal connections

Input to terminals marked 200V.

Output from terminals marked 160, 180, 220, 240V.

Star point terminal marked S.

3. Installation is by four 0.281 in. diameter fixing holes at  $6.750 \times 5.500$  in. centres located in two brackets attached to the base. The transformer is naturally cooled and should not be mounted closer than one inch to any blanking surface.

#### Testing

4. *Resistance check.*—(1) connect a d.c. supply via a suitable resistance between the S terminal and each of the three terminals marked 240 in turn.

(2) In each case a constant current of 10 amp. shall be applied and maintained for 5 minutes before voltage measurements are taken.

(3) Voltage measurements, between the terminals of the phase in which the current is flowing, should be as follows:—

RESTRICTED

S and 160 the voltage should be 1.25 to 1.4 volts.

160 and 180 the voltage should be 0.075 to 0.08 volt.

180 and 200 the voltage should be 0.059 to 0.065 volt

200 and 220 the voltage should be 0.056 to 0.062 volt.

220 and 240 the voltage should be 0.05 to 0.056 volt.

(4) Disconnect the d.c. supply from the transformer.

5. *Open circuit test.*—(1) Connect terminals 200 to a 3-phase, 400 c/s variable voltage supply. The circuit should be suitably metered to measure the input volts, amperes and watts.

(2) Adjust the line voltage to an average value of 200 volts and keep constant.

(3) The average values of the primary line current should not exceed 0.13 amp. and the differences between individual line currents should not be greater than 0.045 amp.

(4) The total power input should not exceed 40 watts.

(5) The individual voltage on each of the four outputs should lie between:—

Output No. 1: 162 and 166 volts

Output No. 2: 181 and 186 volts

Output No. 3: 221 and 226 volts

Output No. 4: 243 and 247 volts

6. *Short circuit test.*—(1) Connect terminals 200 to a 3-phase, 400 c/s variable voltage supply. The circuit should be suitably metered to measure the input volts, amperes and watts.

(2) Short circuit the terminals of output No. 4 (i.e., marked 240) together, via a set of three current measuring instruments.

(3) Increase the applied voltage until the mean value of the output No. 4 currents is 39.5 amps.

(4) The average value of the input currents should lie between 48.5 and 50.0 amp.

(5) The total power (cold) should not exceed 116 watts.

(6) Maintain the short circuit condition for 5 minutes, after which the total input watts should again be taken. The total input watts (hot) should not increase by more than 12 watts above the "cold" condition.

7. *Insulation resistance test.*—The resistance between terminal S and the frame should not be less than 50,000 ohms using a 250-volt insulation resistance tester.

**RESTRICTED**

## Appendix 3

## DE-ICING TRANSFORMER, ROTAX, TYPE P2403

## LEADING PARTICULARS

Transformer, Type P2403	....	....	....	Ref No. 5UB/7078
Input (3-phase, 250-413 c/s)	....	....	....	208V a.c.
Output	....	....	....	480V, 410V, 320V, 270V a.c.
Power output	....	....	....	4 kVA
Current (max.)	....	....	....	5.65 amp. at 410V
Current (max.)	....	....	....	4.85 amp. at 480V
Air temperature range—				
At 1/3 full load	....	....	....	—65 deg. C and +45 deg. C
At full load	....	....	....	—65 deg. C and +20 deg. C
Altitude ceiling	....	....	....	50,000 ft.
Overall dimensions—				
Length	....	....	....	7.750 in.
Width	....	....	....	7.25 in.
Height	....	....	....	5.222 in.
Weight	....	....	....	15.5 lb. (approx.)

1. The P2403 transformer is identical with that described and illustrated in the main chapter, except for different transformer output voltages as given in the circuit diagram (fig. 1).

2. Electrical connections for the P2403 transformer are as follows:—

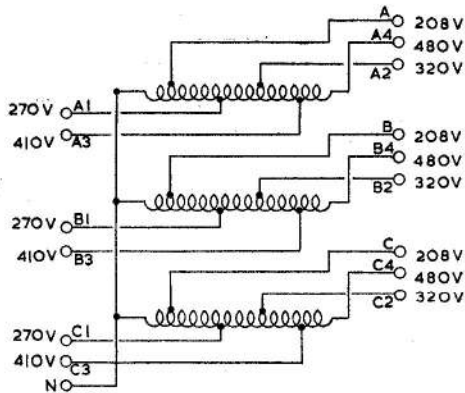

Fig. 1. Diagram of internal connections

208V input to terminals marked A, B and C.

480V output to terminals marked A4, B4, C4.

410V output to terminals marked A3, B3, C3.

320V output to terminals marked A2, B2, C2.

270V output to terminals marked A1, B1, C1.

Star point terminal marked N.

Connections are made via AMP lugs to 2 B.A. terminal studs.

3. Installation is by four 0.281 in. diameter fixing holes at 6.750 × 5.500 in. centres located in two brackets attached to the base. The transformer is naturally cooled and should not be mounted closer than one inch to any blanking surface.

#### Testing

4. Resistance check.—Connect a d.c. supply

RESTRICTED

via a suitable resistance to terminal marked N and A4, B4 and C4 in turn.

Pass a current of 1 amp. through the windings being measured. The mV drop should be as follows:—

Terminal N and terminal A/B/C: 131 to 160mV.

Terminal A/B/C and terminal A1/B1/C1: 56 to 68mV

Terminal A1/B1/C1 and terminal A2/B2/C2: 51 to 63mV.

Terminal A2/B2/C2 and terminal A3/B3/C3: 90 to 110mV.

Terminal A3/B3/C3 and terminal A4/B4/C4: 80 to 98mV.

5. *Open circuit test.*—(1) Connect a 400 cycle, variable voltage supply, to terminals A, B and C.

(2) Adjust the line voltage to an average value of 208 volts.

(3) The average line current should not exceed 0.098 amp. The difference between individual line currents should not be greater than 0.035 amp.

(4) The individual voltage of each of the outputs should lie between:—

Terminal A1, B1 and C1: 266 and 273 volts.

Terminal A2, B2 and C2: 320 and 326 volts.

Terminal A3, B3 and C3: 407 and 417 volts.

Terminal A4, B4 and C4: 485 and 495 volts.

**Note . . .**

*Open circuit voltages should be measured using a moving iron type movement.*

6. *Short circuit test.*—(1) Connect terminals A, B and C to a 400 cycle variable voltage supply.

(2) Short circuit terminals A4, B4 and C4 through suitable ammeters.

(3) Increase the applied voltage until the average value of the output from A4, B4 and C4 is 4.8 amp.

(4) The average value of the input current should lie between 11.0 and 11.6 amp.

(5) Maintain short circuit for 10 minutes.

7. *Insulation resistance test.*—A 250-volt insulation resistance test should be applied between terminal N and the frame. The insulation should not be less than 50,000 ohms.

This file was downloaded  
from the RTFM Library.

Link: [www.scottbouch.com/rtfm](http://www.scottbouch.com/rtfm)

Please see site for usage terms,  
and more aircraft documents.

