

CHAPTER 29

TRANSFORMER RECTIFIER UNIT, ROTAX, TYPE U5501

LIST OF CONTENTS

	Para.		Para.
<i>Introduction</i>	1	<i>Servicing</i>	8
Description	2	<i>Testing</i>	9
<i>Electrical connections</i>	6	<i>Insulation resistance test</i>	10
Installation	7		

LIST OF ILLUSTRATIONS

	Fig.
<i>Transformer rectifier unit, Type U5501</i>	1
<i>Diagram of internal connections</i> ..	2
<i>Test circuit diagram</i>	3

LEADING PARTICULARS

Transformer rectifier unit, Type U5501	Ref. No. 5UC/7041
<i>Transformer input</i>	200V., 3-phase, 400 c/s (terminals A, B, C)
<i>Transformer output</i>	28V. nominal d.c., 60 amp. (terminals + and -)
<i>Rating (continuous)</i>	60 amp. at 28·5V. d.c. (max.)
<i>Temperature</i>	- 40 deg. C. to + 70 deg. C.
<i>Cooling (natural)</i> convection
<i>Altitude</i>	60,000 ft. (max.)
<i>Weight</i>	15 lb. 11 oz.
<i>Overall dimensions—</i>	
<i>Height</i>	7·310 in.
<i>Length</i>	8·000 in.
<i>Width</i>	7·000 in.
<i>Associated equipment</i>	N0306 alternator

Introduction

1. The unit is designed to convert the output of a 30 kVA, 400 c/s three-phase alternator into direct current at 28 volts. It is specifically designed for use in conjunction with the Rotax Type N0306 alternator.

DESCRIPTION

2. The U5501 unit (fig. 1) consists of a three-phase, star—star connected transformer (P12901) and six (handed) diodes interconnected as shown in fig. 2 to form a three-phase full wave bridge.

3. The transformer is wound with "Lewmex" "M" wire and the windings and yoke are vacuum impregnated with varnish to enable the transformer to operate at the temperatures encountered in the unit.

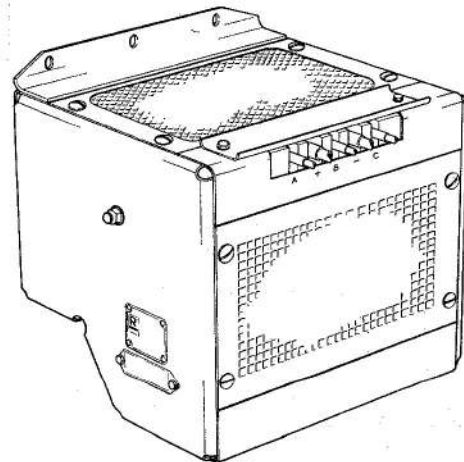

Fig. 1. Transformer rectifier unit, Type U5501

RESTRICTED

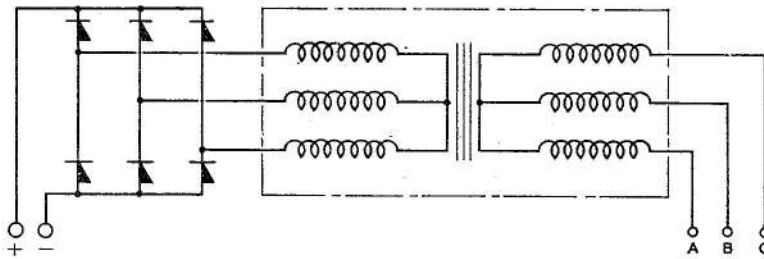

Fig. 2. Diagram of internal connections

4. Three diodes of one polarity are mounted on one heat sink, and the three diodes of opposite polarity on a second heat sink.

5. The above components are mounted in the main frame assembly, which also supports the cover panels. Two of these panels are square perforated; one is of expanded aluminium, and all three are held in position with quick-release fasteners, thus being easily detachable.

Electrical connections

6. The 200-volt, three-phase input is made via three 10-32 U.N.F. studs which accept Prenal cable lugs N.104600/53 (Ref. No. 5X/6669). Output connections are made via two 0.250 in.—28 U.N.F.—2A studs which accept Prenal cable lugs N.104600/20 (Ref. No. 5X/6520).

INSTALLATION

7. The unit should be installed so that in normal flight, the expanded aluminium cover is uppermost and the square perforated covers

are unobstructed at each side. The unit is secured in position by means of two 10-32 U.N.F. anchor nuts at 5.0 in. centres on the base of the frame, and a bracket provided with three slots 0.218 in. wide and 0.343 in. long with 2.6 in. centres which is situated at one edge of the frame.

SERVICING

8. Servicing is normally confined to ensuring that the unit is clean and free from damage; all terminal block screws and external nuts and screws should be checked for tightness. The insulation of the connecting leads should be examined for signs of fraying or deterioration and all connections should be checked to ensure that they are secure.

Testing

9. Connect the unit as shown in the test circuit diagram (fig. 3).

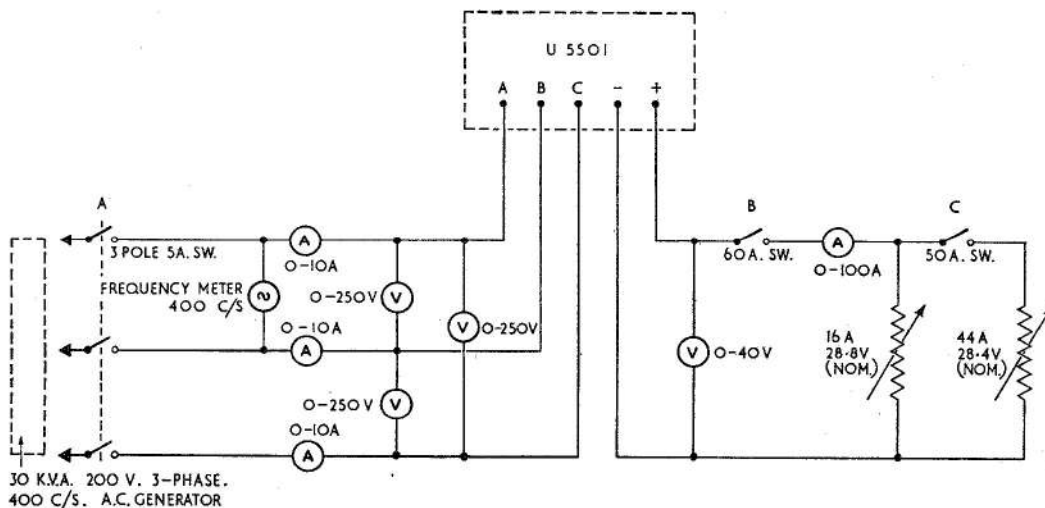

Fig. 3. Test circuit diagram

RESTRICTED

Note . . .

Only a.c. meters—moving iron or Dynamometer type (400 c/s)—should be used. During the test the input voltage and frequency should be constant at 200 volts and 400 c/s respectively.

- (1) Close switch A and with switches B and C open, increase the input voltage to 200 volts (mean) at 400 c/s. The d.c. voltage should lie between 29·5 to 30·5 volts.
- (2) Close switch B and increase the d.c. load to 16 amp. The mean a.c. input current should not be greater than 1·75 amp. and the d.c. voltage should not be less than 28·4 volts.

- (3) Close switch C and increase the d.c. load to 60 amp. The mean a.c. input current should not be greater than 6·6 amp. and the d.c. voltage should not be less than 27·6 volts.

Insulation resistance test

10. The insulation resistance when measured with a 250-volt insulation resistance tester should be not less than 0·5 megohm (for R.N.) or 5 megohms (for R.A.F.) when checking the points enumerated below:

- (1) Between terminal A and the frame.
- (2) Between terminal A and the negative.
- (3) Between terminal negative and the frame.

RESTRICTED

This file was downloaded
from the RTFM Library.

Link: www.scottbouch.com/rtfm

Please see site for usage terms,
and more aircraft documents.

