

Chapter 34

VOLTAGE TRANSFORMER, ROTAX, TYPE P5901

LIST OF CONTENTS

	Para.		Para.
<i>Introduction</i>	1	<i>Testing</i>	8
Description	2	<i>Resistance tests</i>	9
Installation	5	<i>Open circuit tests</i>	10
Servicing	7	<i>Short circuit tests</i>	11
		<i>Load test</i>	12
		<i>Insulation resistance tests</i>	13

LIST OF ILLUSTRATIONS

	Fig.		Fig.
<i>General view of Type P5901</i>	1	<i>Circuit diagram</i>	2

LEADING PARTICULARS

Voltage transformer, Type P5901	Ref. No. 5UB/6855
<i>Input</i>	208 V, 3-phase, 308 to 560 c/s
<i>Output</i>	115 V at full load, single-phase
<i>Load</i>	325 VA at 0.8 p.f. lag
<i>Temperature range</i>	-30 deg. C. to +50 deg. C.
<i>Cooling</i>	natural
<i>Overall dimensions:—</i>	
<i>Length</i>	5.656 in.
<i>Width</i>	3.00 in.
<i>Height</i>	5.500 in.
<i>Weight</i>	4 lb. 12 oz.

Introduction

1. The voltage transformer, Type P5901, is designed to supply special equipment within the aircraft. It converts an input of 208 volts, 400 c/s, 3-phase a.c. to an output of 115 volts, single-phase a.c.

DESCRIPTION

2. The Type P5901 consists of a 3-phase transformer with the primary windings star connected. The three secondary windings are connected in series, with one winding opposing to provide a single-phase output.

3. Reference should be made to the circuit diagram shown in fig. 2. The primary winding of transformer A consists of 167 turns of 20 S.W.G. Lewmex "M" wound around the Unisel laminated core in three layers. The primary windings of transformers B and C are also of Lewmex "M" but consist of 167 turns of 22 S.W.G. wound around the core in three layers. The secondary windings of transformers A, B and C are of 83 turns of Lewmex "M" wound around the outside in three layers. The leads from the transformers are brought out through saturated glass sleeving.

RESTRICTED

4. The transformer is contained in an aluminium alloy case with a detachable top cover. The transformer assembly is clamped to four support pillars which are bolted to the base of the unit. The 5-way terminal block is bolted to the top of the transformer assembly and can be reached by removing the top cover plate. The unit should be secured by four bolts passed through the holes in two metal bars which lie beneath the width of the unit and support the base.

INSTALLATION

5. The unit should be mounted in a horizontal position, with the base downwards, and with adjacent surfaces not closer than one inch to the ventilating apertures in the top cover. The unit should be secured by four bolts passed through the 0.218 in. diameter fixing holes; the holes form a rectangle 4.125 in. by 3.00 in.

6. The three input leads should be connected, in their correct phase sequence, to the 2 amp. terminals marked A, B and C. The two output leads should be connected to the 3 amp. terminals marked a and b.

SERVICING

7. The unit should be inspected to ensure that it is clean and free from damage, and that all nuts and bolts are tight. Examine the insulation of the connecting leads for signs of deterioration and ensure that all connections are secure.

Testing

8. Inspect all soldered connections for dry or high resistance joints.

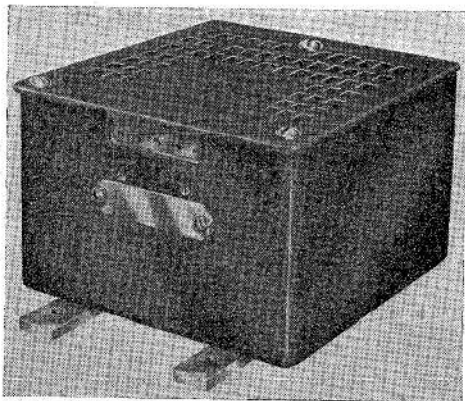

Fig. 1. General view of Type P5901

Resistance tests

9. (1) The resistance between terminals A and B, and A and C should be between 1.18 and 1.31 ohms.
- (2) The resistance between terminals B and C should be between 1.42 and 1.6 ohms.
- (3) The resistance between terminals a and b should be between 0.49 and 0.56 ohm.

Open circuit tests

10. (1) With the terminals a and b open circuit, connect a 3-phase 400 c/s, supply to terminals A, B and C.
- (2) Increase the voltage to a mean line value of 208 volts.
- (3) The average value of the primary line currents should not exceed 0.27 amp.
- (4) The value of the secondary line voltage should be 119 volts ± 1 volt.
- (5) The difference between the individual line currents should not be greater than 0.12 amp.

Short circuit test

11. (1) Connect a variable 3-phase, 400 c/s supply to terminals A, B and C, and connect an ammeter across terminals a and b.
- (2) Increase the voltage until the ammeter indicates 2.9 amp.
- (3) The average value of the primary line current should be between 1.28 and 1.35 amp.
- (4) The difference between the individual line currents should not be greater than 1.2 amp.

Load test

12. (1) With the input supply still connected to terminals A, B and C, connect a preset load of 260 watts at 0.8 p.f. lag. to terminals a and b.
- (2) Increase the input voltage to a mean line value of 208 volts.
- (3) The output voltage should be between 114 and 116 volts.

RESTRICTED

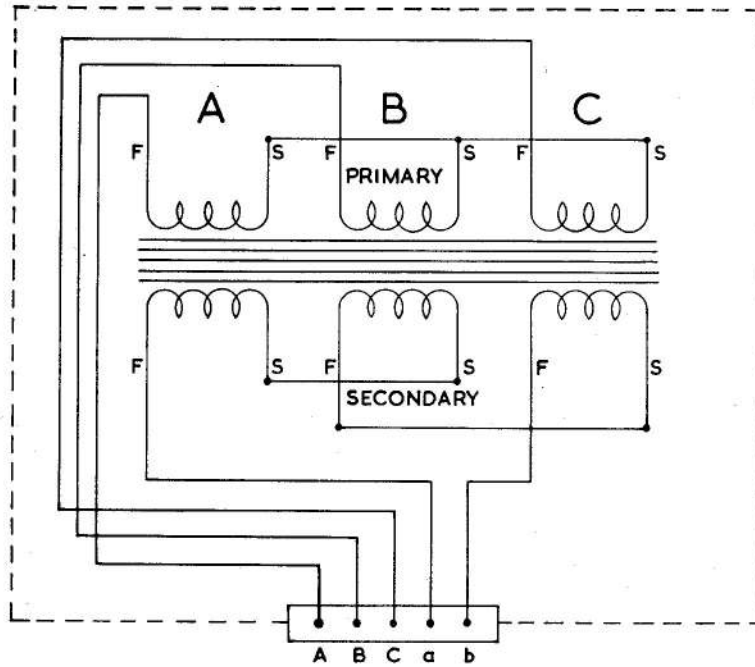

Fig. 2. Circuit diagram

Insulation resistance tests

13. The resistance between the following points should be tested with a 250 volt insulation resistance tester and, in every case, a reading of 0.5 megohm (R.N.) or 5 megohms (R.A.F.) obtained.

- The primary windings and the core.
- The secondary windings and the core.
- The primary windings and the secondary windings.
- The primary windings and the case.
- The secondary windings and the case.

RESTRICTED

This file was downloaded
from the RTFM Library.

Link: www.scottbouch.com/rtfm

Please see site for usage terms,
and more aircraft documents.

