

## Chapter 5

### COMPOUNDING AND MERTZ-PRICE TRANSFORMER, ROTAX, TYPE P8006

#### LIST OF CONTENTS

|                            | <i>Para.</i> |                               | <i>Para.</i> |
|----------------------------|--------------|-------------------------------|--------------|
| <i>Introduction</i> ... .. | 1            | <i>Installation...</i> ... .. | 4            |
| <b>Description</b> ... ..  | 2            |                               |              |

#### LIST OF ILLUSTRATIONS

|                                      | <i>Fig.</i> |                                      | <i>Fig.</i> |
|--------------------------------------|-------------|--------------------------------------|-------------|
| <i>Type P8006 transformer</i> ... .. | 1           | <i>Diagram of connections</i> ... .. | 2           |

#### LEADING PARTICULARS

*Overall dimensions:—*

|                                |  |                |
|--------------------------------|--|----------------|
| <i>Length</i> ... ..           |  | 6.312 in. Max. |
| <i>Width</i> ... ..            |  | 5.812 in. Max. |
| <i>Height</i> ... ..           |  | 6.250 in. Max. |
| <i>Estimated weight</i> ... .. |  | 5.5 lbs.       |

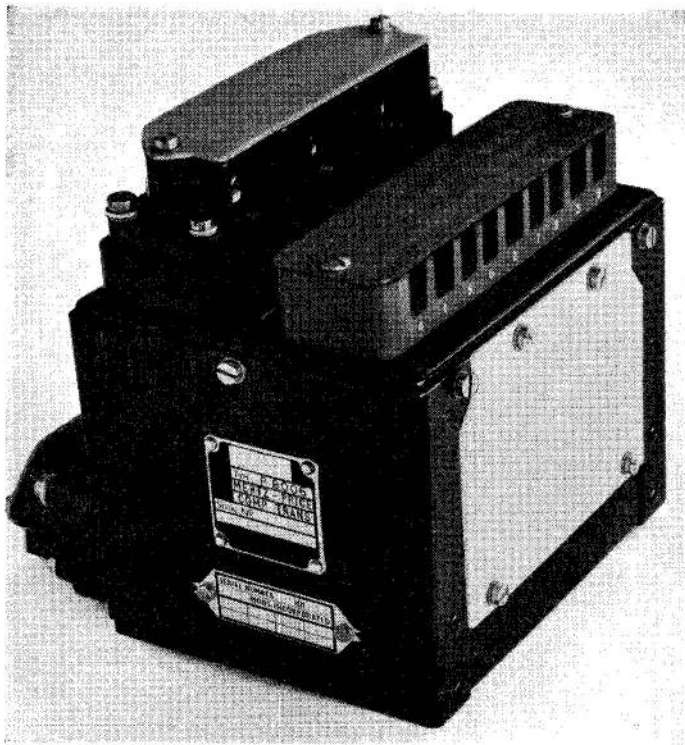

**Fig. 1. Type P8006 Transformer**

F.S./1

(A.L.10, Dec. 58)

**RESTRICTED**

### Introduction

1. The type P8006 transmitter unit has been designed to provide compounding and Mertz-Price protection for Generator Type 159 (Rotax BA1501) when used in conjunction with control unit U4901.

### DESCRIPTION

2. The unit consists of two 3-phase current transformers. One of these is star connected and provides a component of alternator excitation proportional to the load current. The other transformer provides Mertz-Price protection and is designed to operate an external relay, the function of the relay being to switch off the associated alternator in the event of a line to line or line to neutral fault.

In order to eliminate handed units the secondary windings of the protection transformer which are normally connected in delta, are brought out as open windings to terminals 5 and 6, 7 and 8, 9 and 10.

3. The two transformers (*para. 2*) are housed within a common casing and their terminal connections are contained in moulded shrouds. The terminals are annotated to conform with those shown in fig. 2.

### INSTALLATION

4. The unit is mounted to the aircraft frame and secured by 4-2 B.A. screws locating in stiff anchor nuts integral with the case assembly.

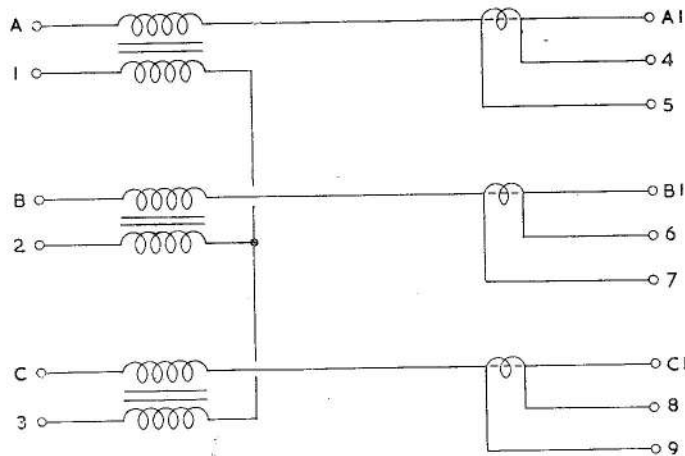

Fig. 2. Diagram of connections

**RESTRICTED**

This file was downloaded  
from the RTFM Library.

Link: [www.scottbouch.com/rtfm](http://www.scottbouch.com/rtfm)

Please see site for usage terms,  
and more aircraft documents.

