

held C

See AP.113D-0401-1  
Issued Feb 1965

### Chapter 6

## TRANSFORMERS, FERRANTI TYPES

### LIST OF CONTENTS

	Para.		Para.
<i>Introduction</i> ... ..	1	<b>Testing</b>	
<b>Description</b> ... ..	2	<i>No load test</i> ... ..	5
<b>Servicing</b> ... ..	3	<i>Full load test</i> ... ..	6

### LIST OF ILLUSTRATIONS

	Fig.		Fig.
<i>Typical Ferranti transformer (Type RD 6609 shown)</i> ... ..	1	<i>Typical terminal arrangement (Type RD 6609 shown)</i> ... ..	2

### LIST OF APPENDICES

	App.
<i>Individual types</i> ... ..	1

#### Introduction

1. Ferranti transformers are special, high temperature, power transformers. Leading Particulars of individual types are given in Appendix 1 to this chapter.

#### DESCRIPTION

2. A typical transformer is illustrated in fig. 1 and its terminal arrangement is given in fig. 2. Fig. 1 of Appendix 1 to this chapter shows the circuit diagrams of all the transformers listed.

#### SERVICING

3. Very little servicing is possible apart from a routine check to ensure that the unit is securely mounted, free from mechanical damage and that the terminal connections are tight and reasonably clean.

4. Should the operation of the transformer be suspect it should be removed from the

F.S./1

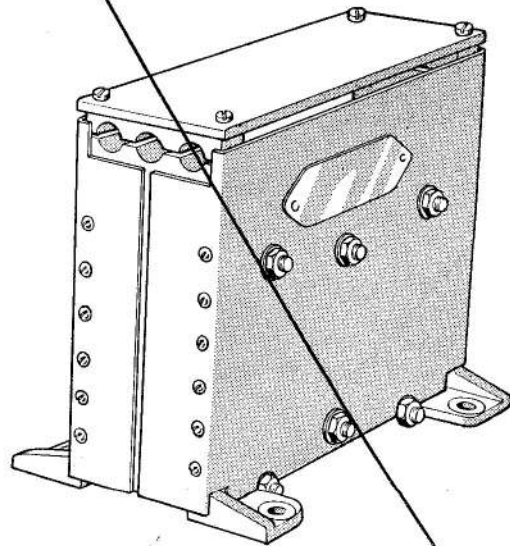

Fig. 1. Typical Ferranti transformer (Type RD 6609 shown)

**RESTRICTED**

aircraft and tested in accordance with the following paragraphs.

### TESTING

#### *No load test*

5. With the primary winding connected to a supply of correct voltage and frequency, the open circuit secondary voltage should be within the limits given in Table 2 of Appendix 1 to this chapter, and the no load line current should not be in excess of the value given in Table 2.

#### *Full load test*

6. With full load secondary current flowing, the secondary voltage should be within the limits given in Table 2.

#### **Note . . .**

*The majority of the transformers listed are not continuously rated, therefore full load must NOT be applied to the secondary for more than five minutes.*

7. The resistance of the windings should be within the tolerances given in Table 2.

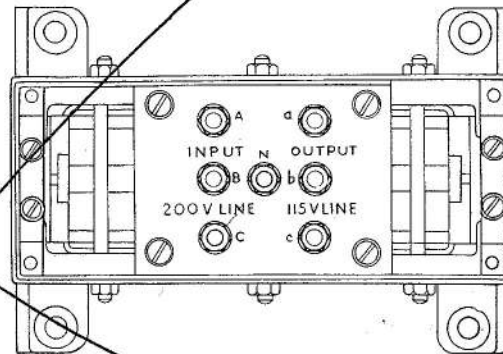

Fig. 2. Typical terminal arrangement (Type RD 6609 shown)

**RESTRICTED**

*See AP 113D-0401-1  
Issue Feb 1965*

**Appendix 1**

**INDIVIDUAL TYPES**

**LIST OF TABLES**

	<i>Table</i>		<i>Table</i>
<i>Leading Particulars</i> ... ..	1	<i>Testing</i> ... ..	2

**LIST OF ILLUSTRATIONS**

	<i>Fig.</i>
<i>Circuit diagrams</i> ... ..	1

**RESTRICTED**

**Table 1**  
**Leading Particulars**

Type	Ref. No.	Type of winding	Input voltage (volt)	Output voltage (volt)	Frequency (c/s)	Full load output (KVA)	Full load secondary current (amp/line)
RD5678	5UB/6429	3-phase star/star	200	115	400	3	15.05
RD5891 (C, No. 1)	5UB/6478	3-phase star/star	200	115	400	1	5
RD5892 (C, No. 2)	5UB/6479	1-phase	200	115	400	0.5	4.35
RD5893 (C, No. 3)	5UB/6480	1-phase	200	70	400	1	14.3
RD5894 (C, No. 4)	5UB/6481	1-phase	200	135(a1-a2) 190(a1-a3)	400	1.1	3.7(a1-a2) 5.79(a1-a3)
RD5895 (C, No. 5)	5UB/6482	1-phase	200	26(a1-a2) 28(a2-a3) 30(a1-a4)	400	0.5	15(a1-a4)
RD6528	5UB/6820	1-phase	115	11.8(9-10) 26(9-11)	400	0.04	1.54
RD6609	5UB/6822	3-phase star/star	200	115	400	1	5
RD6610	5UB/6823	1-phase	200	28	400	1	35.7
RD6611	5UB/6824	3-phase star/star	200	115	400	1 nominal 2 pulsing	10
RD6612A	5UB/6826	1-phase	100(A1-A2) 171(A1-A3) 200(A1-A4)	25	400	2.5	100
RD6613	5UB/9729263	1-phase	200	115	400	1 nominal 2 pulsing	8.7
RD6843	5UB/6865	1 phase	200	73	400	1.25	17.13
RD6844	5UB/6866	1 phase	200	200	400	1.2	6
RD7077	5UB/7423	1 phase	115	26	400	0.028	1.1
RD7093	5UB/7079	1 phase	200	260(a1-a2) 275(a1-a3) 290(a1-a4)	400	1	2.42(a1-a4)
RD7146	5UB/7149	1-phase	200	115	400	0.0025	0.022
RD7159		1-phase	115	84.5	400	0.132	1.56
RD7700	5UB/6885	1-phase	200	265(a1-a2) 285(a1-a3) 305(a1-a4)	400	1.12 (5 min.)	3.67 (5 min.) 2.62 (cont.)
RD8063 (115Y)	5UB/7668	3-phase star/delta	200	115	400	1.4	7
RD8293	5UB/7869	1-phase	115	26	400	0.04	1.54
RD8632	5UB/7799	1-phase	115	115	400	0.008	0.07
RD8825	5UB/7888	1-phase	115	115	400	0.051 (normal) 0.107 (max.)	0.93
RD9222	5UB/7879	1-phase	115	115	400	0.051 (normal) 0.107 (max.)	0.93

The only difference between RD8825 and RD9222 is that RD8825 has terminals through chassis while RD9222 has terminals above chassis.

**RESTRICTED**

See AP 113D-0401-1  
 Issued Feb 1965

**Table 2**  
**Testing**

Type	No load test		Full load test Secondary voltage	Resistance (ohm/phase $\pm 20\%$ unless otherwise stated)	
	Open circuit secondary voltage ( $\pm 2\frac{1}{2}\%$ )	No load line current (amp/line)		Primary	Secondary
RD5678	117.2	2.5	115 $^{+3\%}_{-2\%}$	0.120 $\pm 10\%$	0.024 $\pm 10\%$
RD5891	120	1.8	115 $^{+4\%}_{-1\%}$	0.307	0.193
RD5892	119.5	1.8	115 $^{+4\%}_{-1\%}$	0.584	0.325
RD5893	75.8	1.8	70 $^{+7\%}_{-1\%}$	0.511	0.133
RD5894	139(a1-a2)	1.8	135 $^{+3\frac{1}{2}\%}_{-1\frac{1}{2}\%}$ (a1-a2)	0.76	0.481(a1-a2)
	206.2(a1-a3)		190 $^{+8\%}_{-2\%}$ (a1-a3)		0.714(a1-a3)
RD5895	26.92(a1-a2) 28.85(a1-a3) 30.78(a1-a4)	0.95	30 $\pm 3\%$ (a1-a4)	0.846	0.020(a1-a4)
RD6528	12.3(9-10) 27.1(9-11)	0.13	11.7(9-10) 26(9-11)	$\pm 2\frac{1}{2}\%$ 6.0 $\pm 15\%$	continuity only
RD6609	117.4	1.7 (phases A & C)	115 $^{+2\%}_{-3\%}$	0.836 (A-B and B-C)	0.281 (a-b and b-c)
		0.9 (phase B)		0.886 (C-A)	0.326 (c-a)
RD6610	28.6	1.1	28.6 $\pm 2\frac{1}{2}\%$	0.26	continuity only
RD6611	117.2	2.5	115 $^{+3\%}_{-2\%}$	0.12 $\pm 10\%$	continuity only
RD6612A	25.8	1.5	25 $\pm 2\frac{1}{2}\%$	continuity only	continuity only
RD6613	116	1.8	115 $\pm 2\frac{1}{2}\%$	0.164 $\pm 30\%$	0.099
RD6843	80	1.8	73 $^{+7\%}_{-2\frac{1}{2}\%}$	0.511	0.139
RD6844	214.8	1.8	200 $^{+5\frac{1}{2}\%}_{-3\frac{1}{2}\%}$	0.76	0.76
RD7077	27.2	0.2	26	6.4 $\pm 15\%$	continuity only
RD7093	284(a1-a2) 301(a1-a3) 314(a1-a4)	1.8	260(a1-a2) 275(a1-a3) 290(a1-a4)	0.77	2.23
RD7146	115	0.007	115 $\pm 0.5\%$	69 $\pm 15\%$	30.4 $\pm 15\%$
RD7159	86.9	0.35	84.5	1.02	0.72
RD7700	284(a1-a2) 304(a1-a3) 325(a1-a4)	1.7	265(a1-a2) 285(a1-a3) 305(a1-a4)	0.633	1.28
RD8063	116.9	0.9	115 $\pm 2\frac{1}{2}\%$	0.231	0.138
RD8293	27.3	0.16	26 $\pm 2\frac{1}{2}\%$	4.9	0.46
RD8632	119.3	0.08	115 $\pm 2\frac{1}{2}\%$	20.4 $\pm 15\%$	29.6 $\pm 15\%$
RD8825	118.6	0.52	115 $\pm 2\frac{1}{2}\%$	1.58 $\pm 10\%$	1.81 $\pm 10\%$
RD9222	118.6	0.52	115 $\pm 2\frac{1}{2}\%$	1.58 $\pm 10\%$	1.81 $\pm 10\%$

**RESTRICTED**

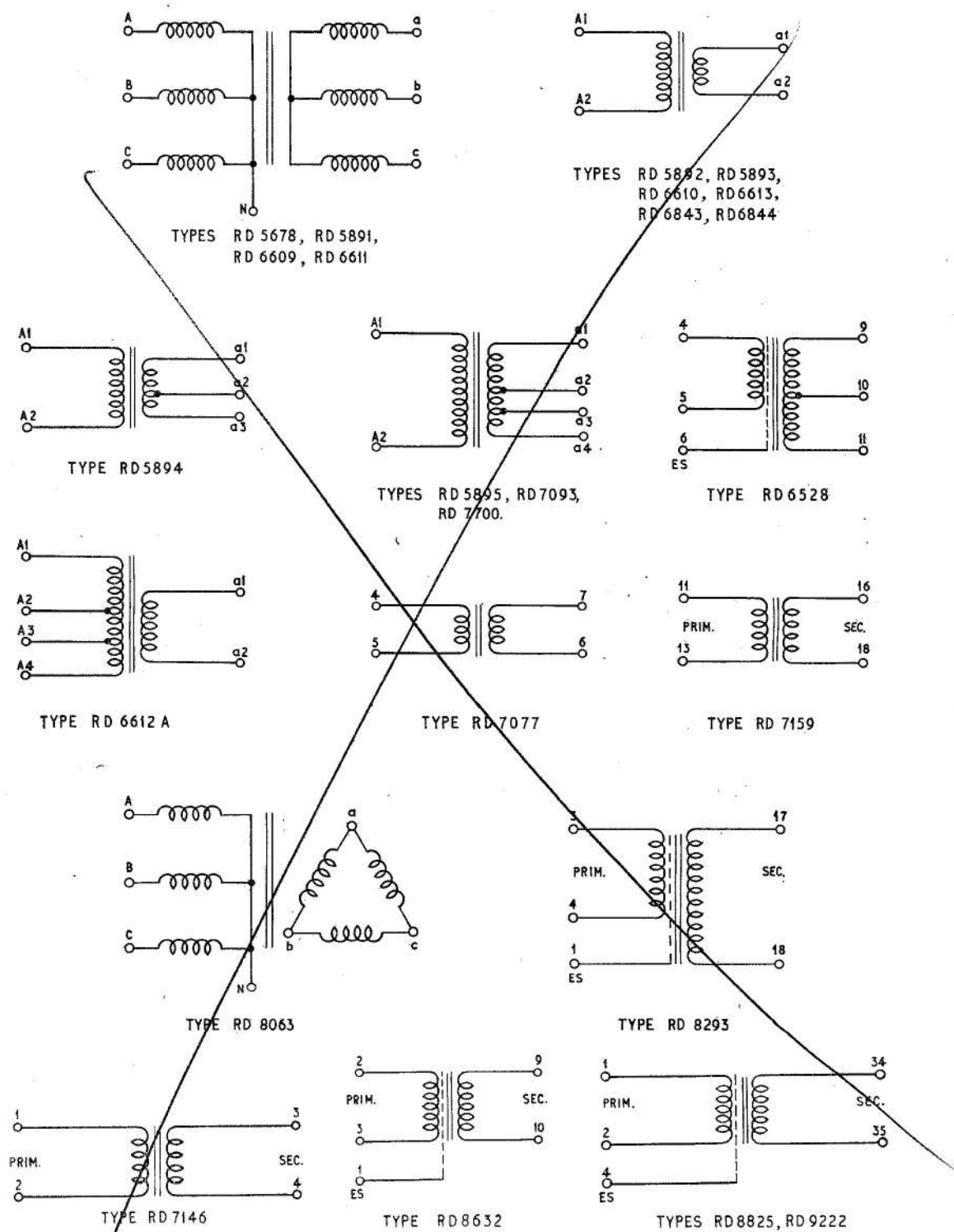

Fig. 1. Circuit diagrams

**RESTRICTED**

This file was downloaded  
from the RTFM Library.

Link: [www.scottbouch.com/rtfm](http://www.scottbouch.com/rtfm)

Please see site for usage terms,  
and more aircraft documents.

