

Now 113D - 07197-1

Chapter 10

REGULATOR UNIT, ROTAX, TYPE ZA 6402/1

LIST OF CONTENTS

	Para.		Para.
Introduction	1	Electrical connections	19
Description	3	Servicing	20
Operation	11	Insulation resistance test	27
Installation	17		

LIST OF ILLUSTRATIONS

	Fig.		Fig.
General view of Type ZA 6402/1 regulator unit	1	Rear view of regulator unit	2
		Circuit diagram	3

LEADING PARTICULARS

Regulator unit, Type ZA6402/1	Ref. No. 5UC/6538
Control voltages—	
M.V.	112V d.c.
L.V.	28V d.c.
A.C.	208V a.c.
Resistor values—	
M.V. control coil (RV7)	90 ohms
L.V. control coil (RV3)	400 ohms
A.C. control coil (RV12)	400 ohms
Regulators—	
M.V. (X2) Stones Type LH/V1 (R.P.3040) (Ref. No. 5UC/7034)
L.V. (X1) Newton Type 37/53996E (Ref. No. 5UC/6611)
A.C. (X3) Newton Type 50/52811E (Ref. No. 5UC/6609)

Introduction

1. The ZA6402/1 regulator unit is part of the U2704/1 transformer rectifier unit, but dispatched as a separate item for transport purposes only, and subsequently fitted to the transformer rectifier unit prior to installation in the aircraft.

2. The regular unit provides control for the three independent maximum outputs of the transformer rectifier unit, i.e., 208 volts a.c., 112 volts d.c. and 28 volts d.c., each circuit being independently regulated to maintain a constant voltage to the associated busbar and de-icing systems.

RESTRICTED

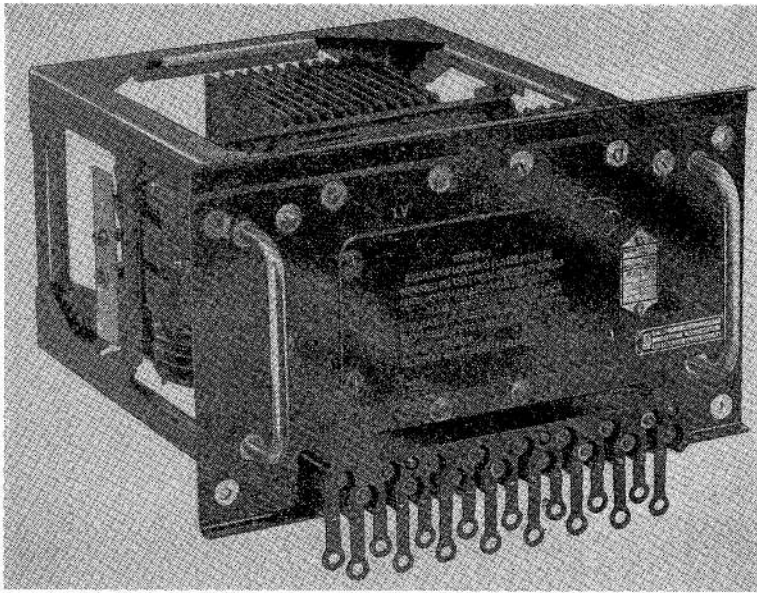

Fig. 1. General view of Type ZA6402/1 regulator unit

DESCRIPTION

3. The ZA 6402/1 regulator unit (fig. 1) comprises three regulators, three resistors, one terminal block incorporating 16 associated connectors and the terminal block cover; in addition two regulator locking plates are included for transport purposes.

4. The three regulators are mounted on a single mounting panel, the L.V. and M.V. regulators being secured to one side, and the a.c. regulator secured to the other side, as shown in fig. 2. The regulators and mounting panel assembly are anti-vibration mounted, whereby eight tension springs keep the complete regulator and mounting panel assembly in full suspension within the chassis framework.

5. Rubber stops are mounted on the chassis framework, to control the movement of the regulator and panel assembly; the stops are mounted on separate channel brackets, which also provide mounting studs for the regulator transport locking plates.

6. For details relative to the instructions given on the inspection cover (located on the front face of the Regulator Unit) for removal of the transport locking plates, see para. 19 under Installation.

7. The three resistors are mounted between two removable fixing brackets, located on the inside face of the chassis frame, and secured by self-locking nut assemblies.

8. Access to the resistors is gained through an inspection cover secured to the front of the main panel by four quick release fasteners.

9. The terminal block is mounted on the front of the main panel by three integral studs retained by the terminal block, and secured on the opposite side of the panel by three self locking nuts.

10. Removal of the regulator unit from the main transformer rectifier unit (U2704/1) for servicing is facilitated by two hand grips positioned on the front panel; the regulator unit is secured in the transformer rectifier unit by four cheesehead screws, locating in self locking nuts fitted to the channel framework of the T.R.U.

Operation

11. A circuit diagram of the regulator unit is given in fig. 3. The 208 volt a.c., low voltage 28 d.c., and medium voltage 112 d.c. systems are combined in the U2704/1 transformer rectifier unit, and form the basic circuit. The two generator rotors are fed via a common positive supply, and the carbon

RESTRICTED

piles of the a.c. and m.v. regulators connected in their corresponding negative leads.

12. When the output voltage of the alternator falls below 208 volts nominal, this causes a fall in voltage at the control coil of the regulator via the P4101 a.c. voltage reference transformer. The regulator carbon pile will compress due to the fall in output voltage, and this will increase the rotor field current; therefore the alternator voltage will rise, due to increase in the rotor field current, and the output voltage will be restored to the 208-volt nominal value.

13. When a load is applied to the 28-volt d.c. output rectifiers, or when the 65-volt winding of the generator falls, the d.c. output voltage from the rectifiers falls below the 28-volt nominal.

14. Pressure on the carbon pile of the L.V. regulator increases slightly, and the pile closes, thereby reducing its resistance. The d.c. control current in the transducer increases; also the input voltage to the primary of the booster transformer increases, thereby boosting the voltage applied to the rectifiers.

15. This boost voltage causes the output voltage from the rectifiers to rise to the 28-volt nominal value. The advantage of using the transducer control is that the transducer can be operated over a wide range of current change whilst the regulator operates over a comparatively narrow range, hence the size and weight of the regulator required is greatly reduced.

16. The M.V. regulator controls the booster rotor current, and maintains the 112-volt supply to the M.V. rectifiers via the current limiting transformer P3701 and the load sharing transformer P1103, and hence to the 112V d.c. busbar.

INSTALLATION

17. The regulator unit ZA6402/1 is specially packed and dispatched separately from the

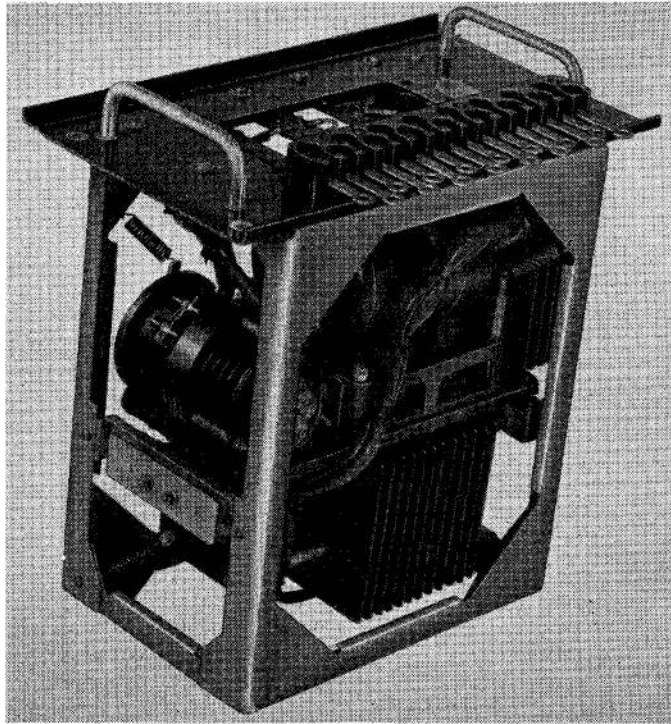

Fig. 2. Rear view of regulator unit

manufacturer as a transport precautionary measure; the unit is subsequently mounted in the U2704/1 transformer rectifier unit prior to installation in the aircraft.

18. The following procedure is recommended for mounting the ZA6402/1 regulator unit to the U2704/1 transformer rectifier unit.

(1) New clamp plate assemblies have been fitted at each end of the a.c. regulator; before assembling the transformer rectifier unit to the aircraft, the new clamp plate assemblies are to be re-fitted in the reverse position, with the locking pegs pointing away from the stop screws.

(2) A transfer, describing the manner in which the new clamp plates are to be fitted, is positioned in the resistor cover inspection plate of the ZA6402/1 regulator unit; an illustration is given in the Service Bulletin No. 995 (2nd issue)

RESTRICTED

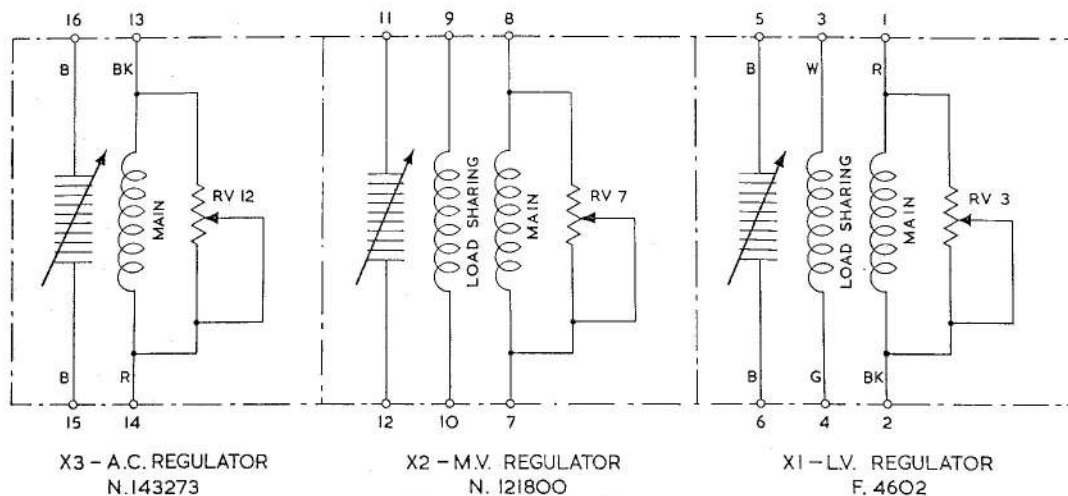

Fig. 3. Circuit diagram

circulated by the manufacturer's service department.

(3) After removal of the transport items finally check the regulator spring suspension for freedom of movement, also the electrical connections of the cable form for any possible damage or loose connections on the underside of the terminal block.

(4) Mount the regulator ZA6402/1 in the frame of the U2704/1 transformer rectifier unit, and carefully fit the terminal connection links to the 2 B.A. studs, integral with the associated terminal block.

(5) Tighten the four mounting screws to secure the regulator to the frame of the T.R.U.

(6) Finally secure the connecting links to the mating terminal block 2 B.A. studs with the associated locking washers and nuts.

(7) Replace the terminal block cover and tighten the six captive nuts to the securing screws on the terminal block.

Electrical connections

19. Electrical connection between the ZA 6405/1 regulator unit and the U2704/1 transformer rectifier unit is by 16 connecting links that bridge the 2 B.A. studs fitted to both terminal block assemblies.

SERVICING

20. Make a visual check of the unit to ensure that it has not sustained any physical damage. Remove the terminal block cover

from the double terminal blocks, and examine the mouldings for signs of cracks or distortion; renew any terminal block if its condition is unsatisfactory.

21. Check that the electrical connections are clean and secure, and that there are no signs of corrosion. Remove the nuts securing the connecting links to terminate 1 to 16 on the terminal block at the lower end of the main frame on the transformer rectifier unit, and unscrew and remove the four securing screws which hold the regulator unit assembly in position.

22. The regulator unit which is mounted on its own chassis may then be withdrawn from the U2704/1 transformer rectifier unit.

23. Make a visual examination of the internal components to ensure that there are no signs of damage or chafed leads and that electrical connections are secure.

24. Examine the regulators for security of mounting on the mounting panel, paying particular attention to the suspension springs; faulty springs should be renewed. Check the rubber stops mounted at each end of the a.c. regulator for distortion or deterioration and renew if faulty.

25. If during servicing it is found necessary to check or adjust the regulator diverter resistance RV3, RV12, or RV7, the resistors should be set between the following values with the generator speed approximately at 8000 r.p.m. and loads of 10 amperes applied to the a.c. busbar and 40 amperes applied to the M.V. and L.V. busbars respectively. (M.V. and L.V. batteries should be disconnected).

RESTRICTED

- (1) 40 and 350 ohms (approx.) for the L.V. resistance (R V 3).
- (2) 50 and 350 ohms (approx.) for the A.C. resistance (R V 12).
- (3) 26 and 40 ohms (approx.) for the M.V. resistance (R V 7).

26. Reduce the generator speed to 6,175 r.p.m. and adjust the relevant external trimmers (shown in U2704/1 transformer rectifier unit circuit diagram) to give 112 volts on the M.V. busbar, 28.3 volts on the L.V. busbar, and 208 volts on the A.C. busbars.

Note . . .

Before any adjustments are made, switch the transformer rectifier off and on twice.

Insulation resistance test

27. The insulation resistance should be

measured between the following points, with a 250 volt insulation resistance tester; the reading should not be less than 5 megohms.

- (1) Between terminal 16 and earth
- (2) Between terminal 14 and earth
- (3) Between terminal 12 and earth
- (4) Between terminal 10 and earth
- (5) Between terminal 8 and earth
- (6) Between terminal 6 and earth
- (7) Between terminal 4 and earth
- (8) Between terminal 2 and earth

Note . . .

Further tests on the individual regulators will be formed in separate chapters in this book.

RESTRICTED

))

))

)

))

)

This file was downloaded from the RTFM Library.
Link: www.scottbouch.com/rtfm

Please see site for usage terms, and more aircraft documents.

