

Chapter 13

VOLTAGE REGULATOR REFERENCE UNIT, E.E., TYPE AE7506, Mk. 3
and
VOLTAGE REGULATOR AMPLIFIER UNIT, E.E., TYPE AE7511, Mk. 3

LIST OF CONTENTS

	Para.		Para.
<i>Introduction</i>	1	<i>Stabilizing and feedback</i>	27
Description		Installation	29
<i>Voltage regulator reference unit</i>	5	Serviceing	32
<i>Voltage regulator amplifier unit</i>	8	Testing	33
Operation		<i>Wiring check</i>	35
<i>Machine under steady state load</i>	13	<i>Functional test</i>	37
<i>Machine under increasing load</i>	21	<i>Insulation test</i>	40
<i>Machine under decreasing load</i>	24		

LIST OF ILLUSTRATIONS

	Fig.		Fig.
<i>General view of coupled units</i>	1	<i>Test circuit diagram</i>	4
<i>Wiring diagram, Type AE7506 unit</i>	2	<i>Characteristic curves</i>	5
<i>Wiring diagram, Type AE7511 unit</i>	3		

LEADING PARTICULARS

Voltage regulator reference unit, E.E., Type AE7506, Mk. 3	<i>Ref. No. 5UC/6922</i>
Voltage regulator amplifier unit, E.E., Type AE7511, Mk. 3	<i>Ref. No. 5UC/6923</i>
<i>Bus-bar voltage</i>	200V r.m.s.
<i>Bus-bar frequency</i>	400 c/s
<i>Number of phases connected to unit</i>	3
<i>Voltage regulation</i> (over full climatic and load range)	±4V r.m.s.
<i>Regulator load</i>	1 ohm nominal
<i>Regulator output</i>	3A nominal
<i>Time rating</i>	Continuous
<i>Cooling</i>	Blast air 1.0 lb/min up to +85°C (with 2 min. in 7 min. at +115°C)
<i>Temperature range</i>	-65° to +110°C
<i>Altitude range</i>	0 to 60,000 ft.
Overall dimensions (units assembled)	
<i>Length</i>	9.760 in.
<i>Width</i>	5.05 in.
<i>Height</i>	6.5674 in.

RESTRICTED

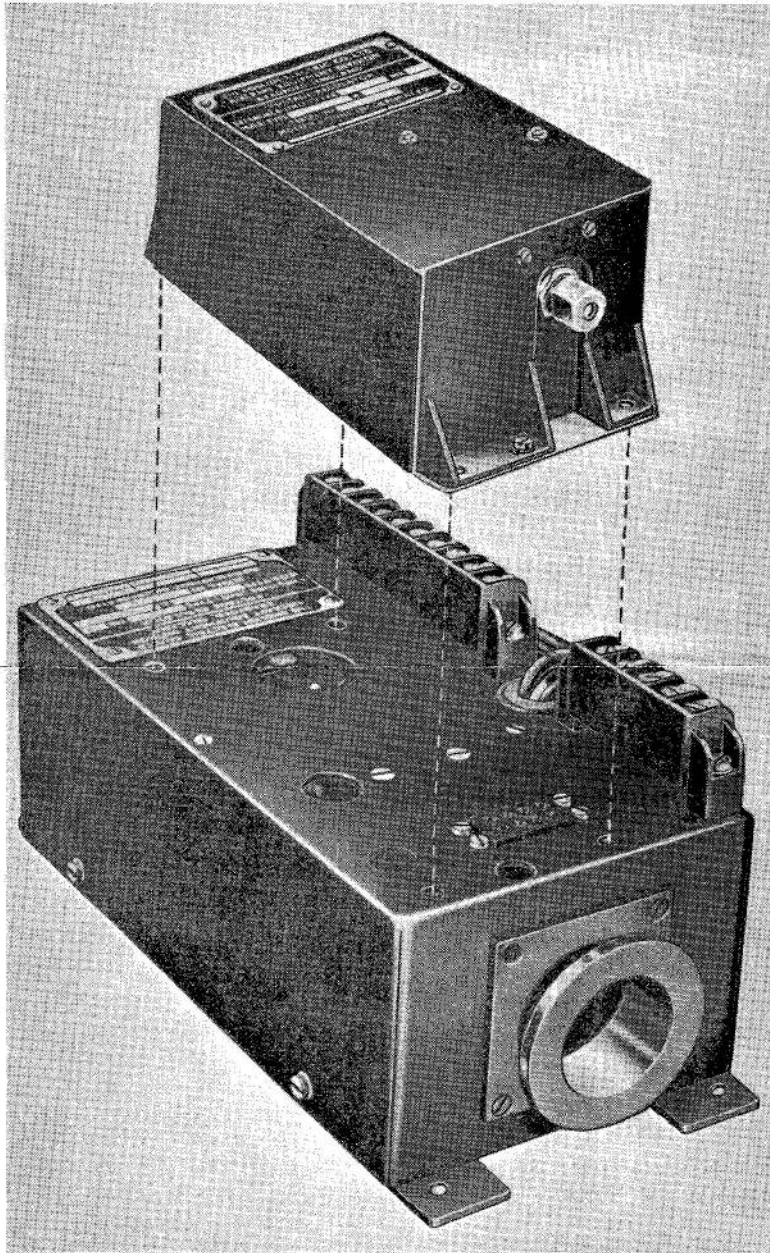

Fig. 1. General view of coupled units

RESTRICTED

Introduction

1. The two units described in this chapter are constructed as two separate assemblies and are designed electrically and mechanically to be fully interchangeable with units of the same type and mark number.
2. The function of the two units is to regulate the output voltage of the a.c. generator throughout the full load and temperature range of the machine. The regulator is used in association with the Types 162 or AE2054 a.c. generators.
3. The AE7506 unit is mounted directly above the AE7511 unit and is secured by four 4 B.A. screws. The units are interconnected by a 'Unitor' plug and socket, and external connections are made through Plessey 'quick release' terminal blocks.
4. Blast air is fed to the AE7511 unit and a small proportion bled off to the AE7506 unit, all used air is then spilled to the atmosphere through louvres positioned at the end of the AE7511 unit.

DESCRIPTION**Voltage regulator reference unit**

5. This is the voltage sensing and first stage amplifier of the regulator. The unit senses variations in line voltage, differentiates between increase and decrease, and produces an amplified signal which is fed into the AE7511 unit.
6. The sensing signal is obtained from the generator bus-bars via the terminal block on the AE7511 unit and the Unitor socket, and is then fed to the voltage reference circuit through the full wave bridge rectifier network. The rectified waveform from the bridge network is smoothed by a resistance-capacitance filter, and is then fed to a reference bridge comprising two trigger tubes which function as voltage stabilizers feeding the control winding on the single phase transducer. The secondary winding of the single phase double wound 250/50V transformer supplies the a.c. windings of the magnetic amplifier circuit. Hence the transducer provides the first stage amplification of any error signal produced by the voltage sensing circuit. The error signal is then fed to the AE7511 unit through the socket/plug connection.

7. Reference should be made to A.P.4343, Vol. 1, Sect. 1, Chap. 3, for general details of magnetic amplifier principles.

Voltage regulator amplifier unit

8. This unit contains the second stage three phase magnetic amplifier, filter and damping networks, flux reset and exciter voltage feedback circuits.
9. The output phases of the generator are connected to terminals A, B and C on the terminal block, and energize the primary (delta) winding of a three phase step down transformer. The secondary (star) winding energizes the a.c. windings of the three phase magnetic amplifier.
10. The amplifier, which is positioned between the delta/star transformer and the damping transformer, has two control windings. The first winding is supplied from the AE7506 unit via a resistance capacitance filter network (R5, R6 and a $2\mu\text{F}$ capacitor). This network functions as an attenuator for harmonic feedback and filter to the second stage amplifier input control winding.
11. The second control winding is supplied by the secondary winding of the damping transformer in series with a 5 ohm resistor, which forms part of a potential divider network connected to the machine pilot exciter armature.
12. The regulator output current is fed via an external bridge connected rectifier network to the pilot exciter field on the generator. The d.c. exciter of the generator has two field windings, one of which is used to bias the exciter characteristic to a suitable working point. The other winding is wound in two halves and is connected in a bridge circuit with two resistors; the output of the regulator is fed into the bridge and opposes the self-excitation of the machine exciter.

OPERATION**Machine under steady state load**

13. Under this load condition the unit functions as follows. A three phase tapping is fed off the generator bus-bars to the rectifier bridge in the voltage reference circuit of the type AE7506 unit, and the rectified output of approximately 260V is smoothed by a resistance capacitance filter in parallel with the bridge network.

RESTRICTED

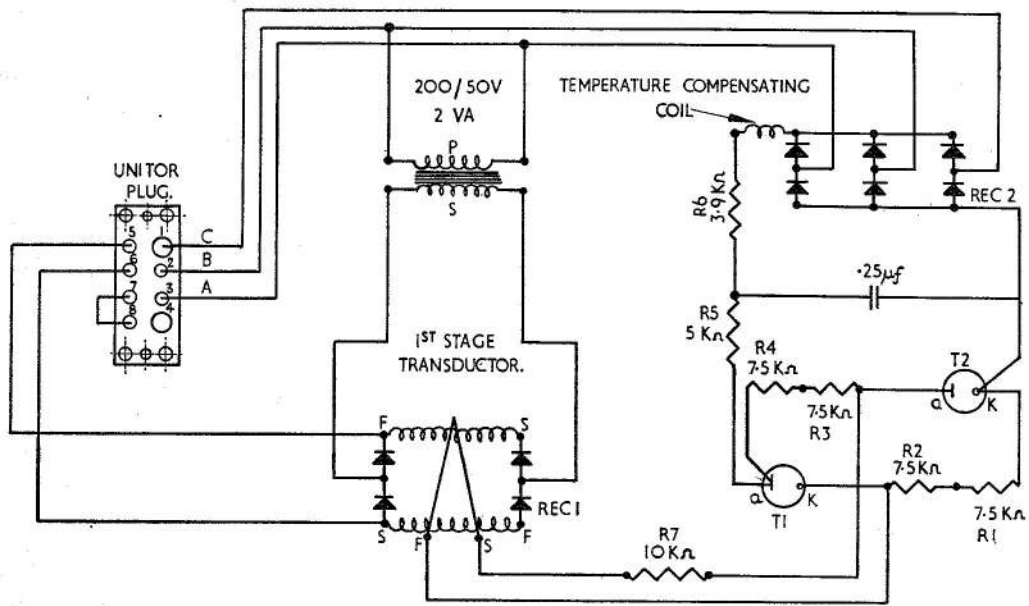

Fig. 2. Wiring diagram, Type AE7506 unit

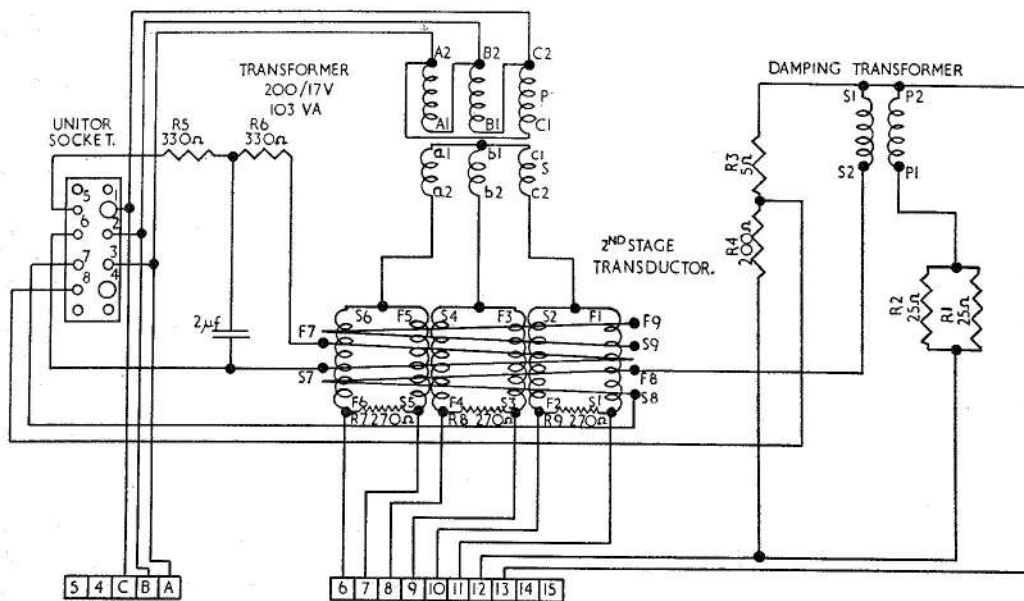

Fig. 3. Wiring diagram, Type AE7511 unit

RESTRICTED

14. The supply from the network is fed to the trigger tube circuit. The initial striking potential of the tubes is 115V d.c. (max), and the applied potential is adjusted through the 5k ohm potentiometer which is in series with the positive line from the bridge rectifier network.

15. After an initial warm up period (3 minutes) the trigger tube maintaining potential is held constant at 85V irrespective of load.

16. It will be seen from fig. 2 that if the bridge is balanced (i.e. the voltage drop in each arm of the bridge is equal) there will be no difference in output potential to the 1st stage magnetic amplifier and no current will flow.

17. The bridge is set up so that it is slightly unbalanced at 200V, thus causing a slight voltage drop across resistors R1, R2, R3, R4, whilst the trigger tube voltage is held at approximately 85V d.c.

18. With the bridge in an unbalanced condition, signal current (proportional to the unbalance) will flow via R7 to the control winding of the first stage magnetic amplifier, under steady load conditions the signal current is approximately 0.5 mA to 1 mA.

19. Under this condition the impedances of the first and second stage magnetic amplifiers remain constant so that small standing currents flow through the flux reset resistors R7, R8 and R9, and appear as unidirectional signals at the generator pilot exciter field windings when rectified by the external bridge elements.

20. Hence any deviation from a steady load condition results in the regulator current opposing the natural excitation of the generator, so that the generator terminal voltage is kept constant at all load levels.

Machine under increasing load

21. Under this load condition the regulator functions as follows. The consequent reduction of generator terminal voltage with application of load produces a small signal to the first stage amplifier, which decreases the impedance of the amplifier main windings, thus producing an increased signal current which is passed to the second stage amplifier control winding.

22. The increased d.c. control current increases the main winding impedance of the

second stage amplifier and hence a smaller a.c. signal across R7, R8 and R9 flux reset resistors.

23. The signal obtained across the resistors is then rectified and the reduced unidirectional voltage opposes the self excitation of the generator (in this case less opposition) thus strengthening the field until the excitation value gives the correct generator voltage. Hence the machine is regulated to within the specified limits, i.e. $200V \pm 2\%$ for the load conditions described.

Machine under decreasing load

24. Under this condition the regulator functions as follows. A high d.c. signal is passed to the control winding of the first stage magnetic amplifier which increases the impedance of the main winding, thus producing a decreased current signal which is passed to the control winding of the second stage amplifier.

25. The reduction in d.c. control current decreases the main winding impedance and hence a larger a.c. signal across R7, R8 and R9.

26. The signal obtained across the flux reset resistors is then rectified and the unidirectional voltage opposes the machine exciter voltage, thus weakening the exciter field and reducing the generator terminal voltage. Hence the machine is regulated to within the specified limits.

Stabilizing and feedback

27. Regulator stabilization is provided by the second control winding of the three phase magnetic amplifier, the damping transformer, and associated components. The feedback loop energizes the secondary of the damping transformer through the potential divider resistors R4 and R3. The damping transformer primary winding is fed by the machine pilot exciter armature through R1 and R2.

28. Any permanent rise or fall in the pilot exciter voltage results in an increase or decrease of the standing current in the second stage control winding, as supplied by the potential divider resistors of the feedback network. Hence, proportional and differential negative feedback is applied to the regulator under normal and transient load conditions.

RESTRICTED

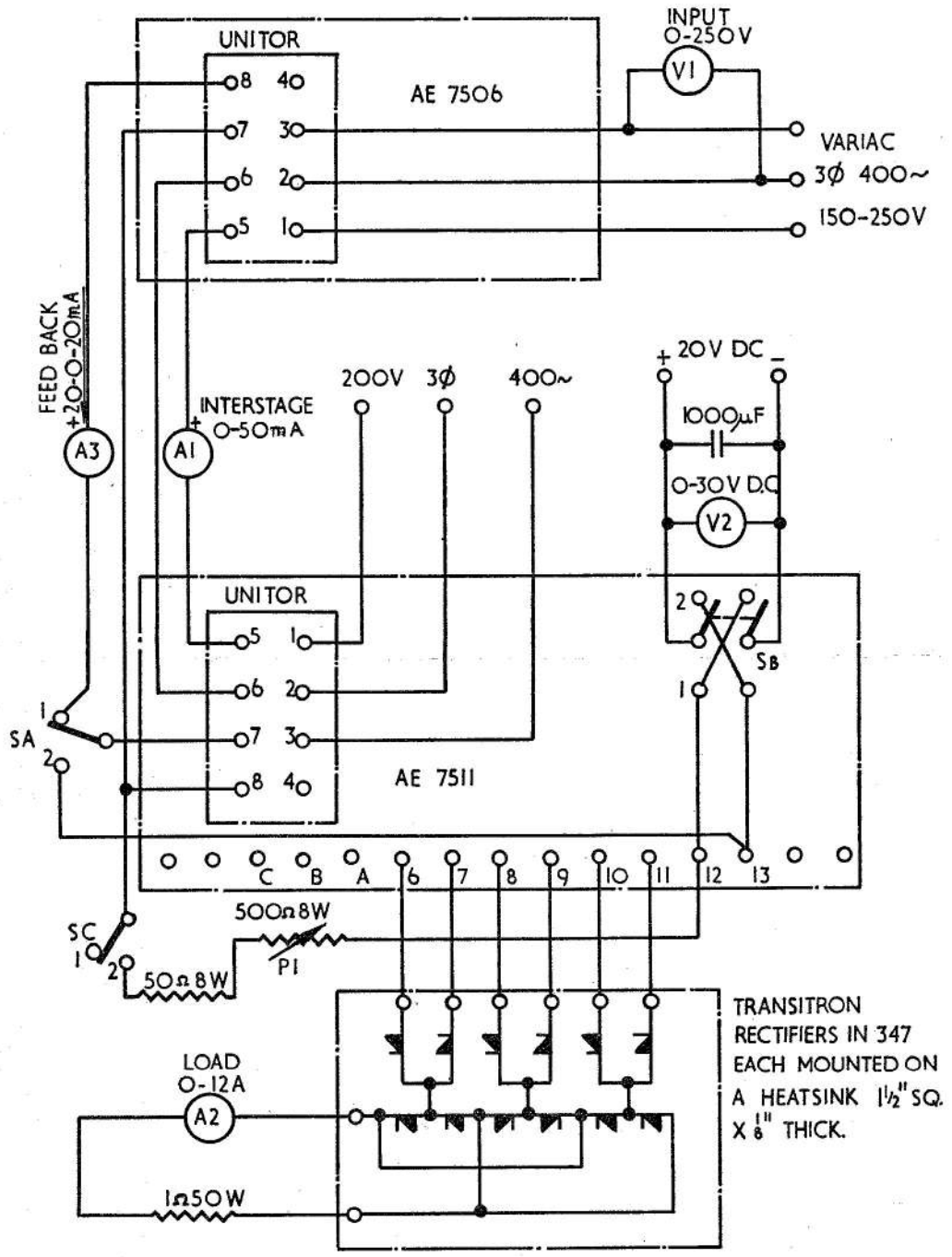

Fig. 4. Test circuit diagram

RESTRICTED

INSTALLATION

29. The units are normally combined as one assembly, the Type AE7506 is mounted on top of the Type AE7511 unit and is secured with four 4 B.A. cheese head screws and washers.

30. The regulator is mounted in the aircraft by the feet provided on the base of the Type AE7511 unit and finally locked in position with four 2 B.A. screws and lockwashers.

31. The external electrical connections are made from the aircraft electrical system to the quick release terminal blocks on the AE7511 unit.

SERVICING

32. Without removing the unit from the aircraft the only servicing necessary is routine inspection for security of mounting and assembly, mechanical damage, and corrosion. The regulator contains no moving parts and as such requires no internal servicing.

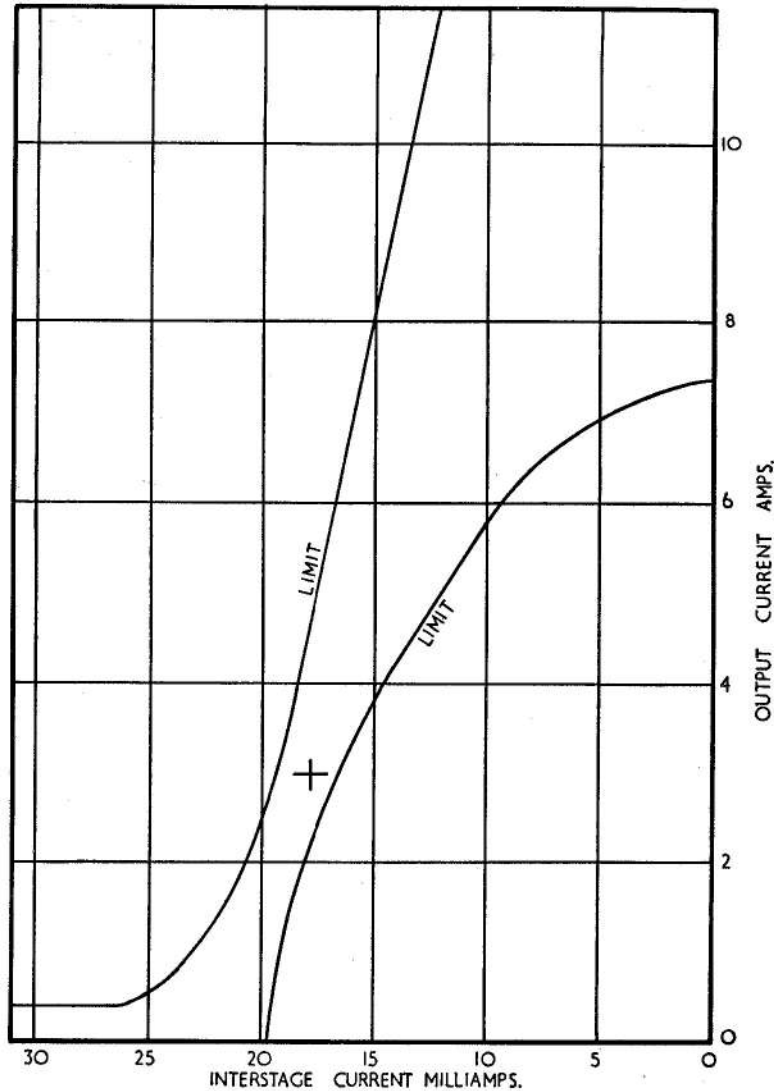

Fig. 5. Characteristic curves

RESTRICTED

TESTING

33. The 400 c/s supply is to have a regulation of less than 1 volt (r.m.s.) and is to be free from sub-harmonic greater than 0.2V (r.m.s.) and harmonics greater than 2% of the fundamental. The output of Type AE2036 or AE2054 (a.c. generator is suitable for this supply.

34. A precision grade meter is to be used for line voltage measurement (r.m.s.), and other meters used may be of industrial standard.

Wiring check

35. It is recommended that the regulator be tested for correct internal connections by resistance measurement between the terminals detailed below.

36. A d.c. resistance measuring device should be used. The prefix 'U' denotes 'Unitor' socket terminals

Terminal	Resistance
A-B B-C C-A	4.7 ± 0.5 ohm
A-U3 B-U2 C-U1	Short circuit
12-13	13.3 ± 0.7 ohm
U6-U5	677 ± 35 ohm

Functional test

37. Connect the unit to the test circuit as shown in fig. 4 with the two units separated.

In the event of one unit being suspect, it should be replaced with a unit of proven serviceability.

38. Close each of the switches SA, SB, SC, to position 1, and adjust V2 to 20V. The feedback current is to be within +5 to +8 mA. Adjust V1 with the variac so that the interstage current A1 is 18 mA. If the output current is less than 3A for this value of interstage current, close switch SC, and adjust the potentiometer P1 so that the output current A2 is 3.0A, the required change in A3 must not be more than 14 mA. Vary the interstage current over the range 0 to 30 mA in at least 10 suitable increments, taking readings of interstage and output current. The characteristic obtained should be within the limits shown in fig. 5 of this chapter.

39. Change switch SA to position 2, open switch SC to position 1, set V2 to 20V, and adjust V1 until the output is 3A. Close switch SB to position 1, and the load current should increase momentarily. Close switch SB into position 2, the load current should decrease momentarily.

Insulation test

40. With the units disconnected from the aircraft electrical system, the insulation resistance of the unit measured at 500 volts d.c. between all terminals and the case is to be greater than 5 megohms.

RESTRICTED

This file was downloaded
from the RTFM Library.

Link: www.scottbouch.com/rtfm

Please see site for usage terms,
and more aircraft documents.

