

Chapter 3

VOLTAGE REGULATOR REFERENCE UNIT, E.E., TYPE AE.7506, MK.2

AND

MAGNETIC AMPLIFIER UNIT, E.E., TYPE AE.7511, MK.2

LIST OF CONTENTS

	Para.		Para.
Introduction	1	Stabilising... ..	33
Description		Installation	34
Voltage regulator reference unit ...	4	Servicing	37
Voltage regulator magnetic amplifier unit	12	Testing	
Operation		General	38
Generator output normal	17	Functional test	39
Generator output above normal	27	Insulation test	41

LIST OF ILLUSTRATIONS

	Fig.		Fig.
General view of coupled units	1	Wiring diagram, Type AE.7511 unit ...	4
Schematic block diagram	2	Test circuit	5
Wiring diagram, Type AE.7506 unit ...	3	Characteristic curves	6

LEADING PARTICULARS

Voltage regulator reference unit, E.E. Type AE.7506, Mk.2	Ref.No. 5UC/6183
Magnetic amplifier unit, E.E., Type AE.7511, Mk.2	Ref.No. 5UC/6345
Line voltage	200V r.m.s.
Line frequency	400 c/s
Phases	3
Normal output	3 amp. d.c.
Output range	0.3 to 9 amp. d.c.
Rating	Continuous when blast air cooled at 1 lb. per minute at 95°C.
Maximum altitude	60,000 ft.
Temperature range	-65°C. to 100°C. ambient

RESTRICTED

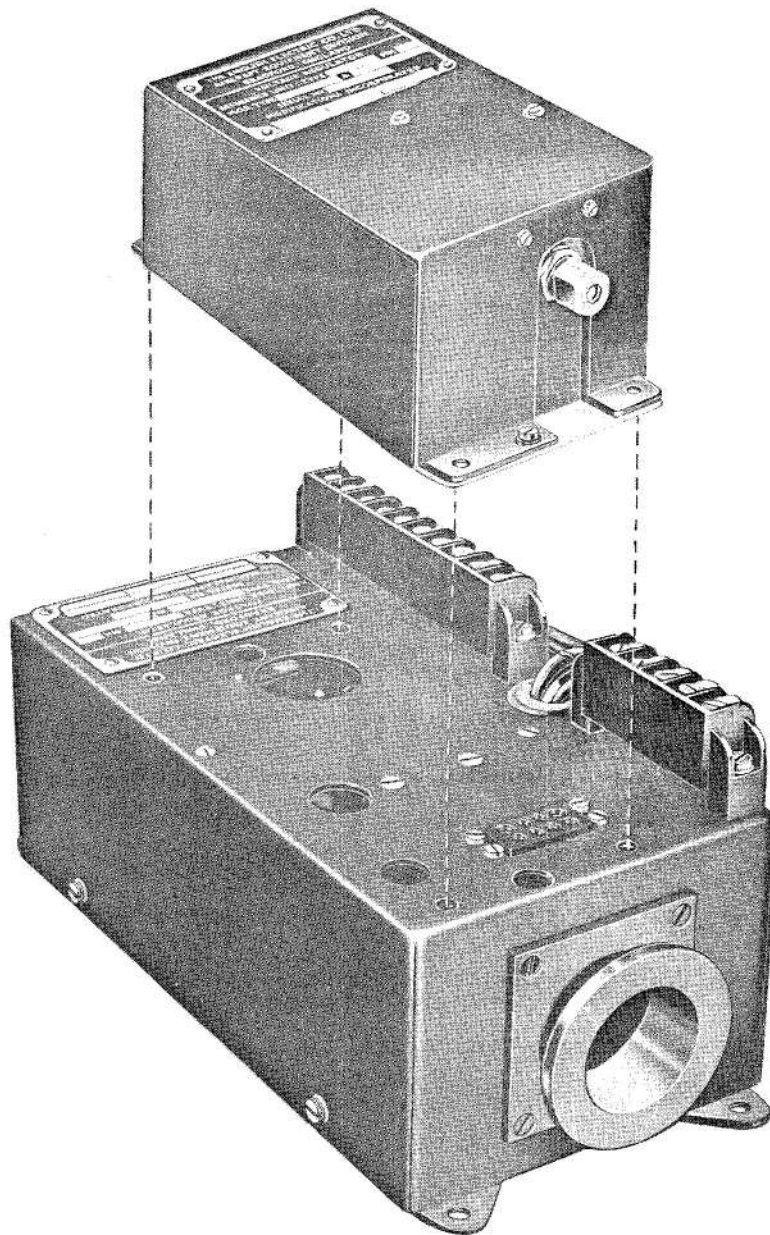

Fig.1 General view of coupled units

Introduction

1. The two units described in this chapter are interconnected electrically and mechanically when installed as part of the electrical control system of the Type 162 a.c. generator.

2. The function of the two units is to control the voltage output of the generator, the control being effected by means of a two-stage amplifier from which the field windings of the d.c. exciter are fed. The schematic block diagram (fig.2) shows the various stages of control.

RESTRICTED

3. The two units are fully interchangeable with others of the same type. The Type AE.7506 is mounted directly on top of the Type AE.7511 and is attached to it by four 4 B.A. screws. Cooling air is necessary to obviate the rise in temperature of the unit components, and this is piped in through an aperture at one end of the Type AE.7511 magnetic amplifier.

DESCRIPTION

Voltage regulator reference unit

4. This is the voltage-sensing and first-stage amplifier unit of the voltage control. A tapping is made into the generator feeder lines, and fed to the unit or plug/socket connection between the two units via the terminal block on the Type AE.7511 magnetic amplifier.

5. The 200V line tapping is then passed to the voltage reference circuit via the full-wave bridge diodes. These are encapsulated together and are positioned next to the balancing potentiometer and the resistor encapsulation near the centre of the unit.

6. The full-wave bridge rectifiers have a 0.25 μ f metallised-paper capacitor connected across them, which, together with a 3.9 k.ohm. resistor situated within the resistor encapsulation, smooths the d.c. output from the rectifiers.

7. Two neon trigger tubes are fitted to a vertical bracket at the opposite end of the unit to the balancing potentiometers.

8. At the back of the unit, next to the resistor encapsulation, is a step-down 200/50V transformer supplying the a.c. windings of the magnetic amplifier, the rectifier encapsulation of which is situated between the trigger tubes and the transducer.

9. Beneath the transformer is an encapsulated coil fitted in the reference circuit

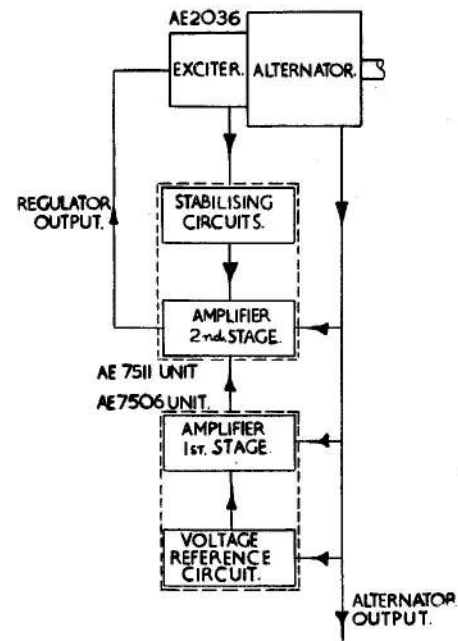

Fig.2 Schematic block diagram

to compensate for temperature variations within the unit.

10. The transducer fitted beneath the encapsulated rectifier assembly provides the first stage amplification of any error signal sensed by the voltage reference circuit and passes it on to the Type AE.7511 unit via the unit or socket/plug connection fitted between the two units.

11. Reference should be made to A.P.4343, Vol.1, Sect.1, Chap.3 for general details of magnetic amplifiers.

Voltage regulator magnetic amplifier unit

12. This unit contains the second stage magnetic amplifier and a damping circuit to stabilise the action of the regulator under transient conditions.

13. The generator output voltage is applied to terminals A, B, C, on the terminal block. This line voltage input is fed to the delta/star step-down transformer which supplies the A.C. windings of the three-phase

RESTRICTED

magnetic amplifier. The transformer is positioned at one end of the unit and is labelled accordingly. The electrical connections to and from the transformer are made through soldered joints to turret lugs attached to the component.

14. The three-phase magnetic amplifier, situated between the step-down transformer and the damping or stabilising transformer, has two control windings. One is supplied from the first-stage amplifier in the Type AE.7506 unit and is passed through an interstage filter circuit of resistors and capacitor which are an encapsulated assembly fitted to the cover above the magnetic amplifier. The other control winding is supplied from the secondary winding of the damping transformer situated at the cooling air inlet end of the unit. The outlet for the cooling air is provided by louvres in the cover at the other end of the unit.

15. In front of the stabilising transformer

are two 25 ohm. resistors mounted one above the other and electrically connected in parallel in the primary circuit of the stabilising transformer to restrict the d.c. current.

16. The output of the two units described above is fed, via a power rectifier bridge, to the d.c. exciter windings of the a.c. generator which is controlled by these units.

OPERATION

Generator output normal

17. The generator feeders are tapped and the supply fed to the full-wave bridge rectifiers in the voltage reference circuit in the Type AE.7506 unit. The rectified output of approximately 265V is applied to the smoothing circuit of a 3.9 k.ohm series resistor and a 0.25 μ f capacitor which is connected across the two lines. This smoothing circuit causes a voltage drop of approximately 45V.

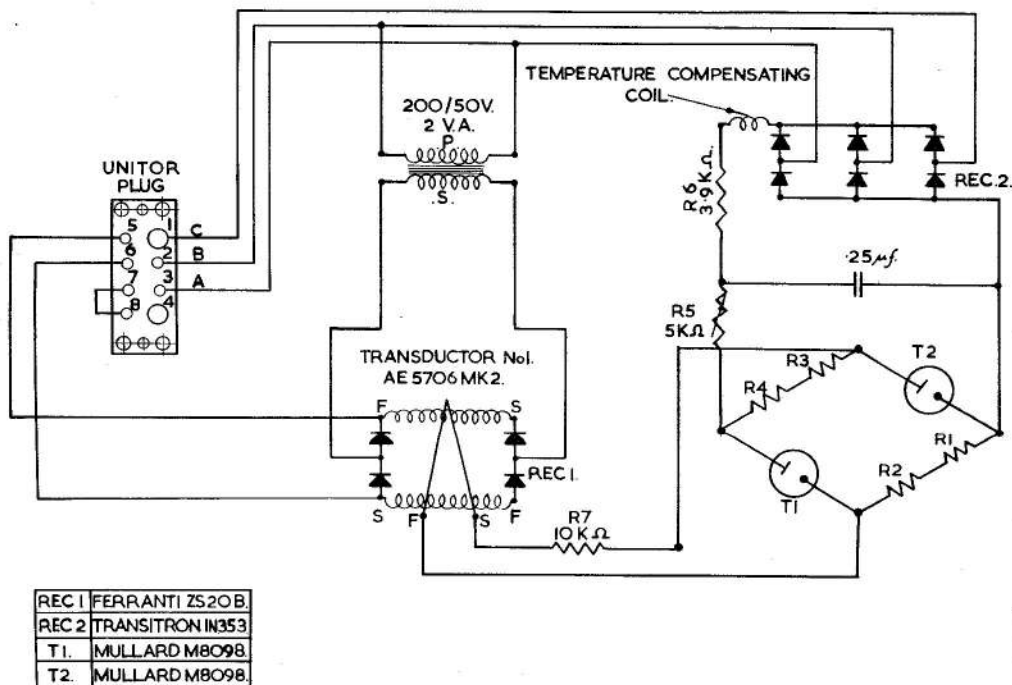

Fig.3 Wiring diagram, Type AE.7506 unit

RESTRICTED

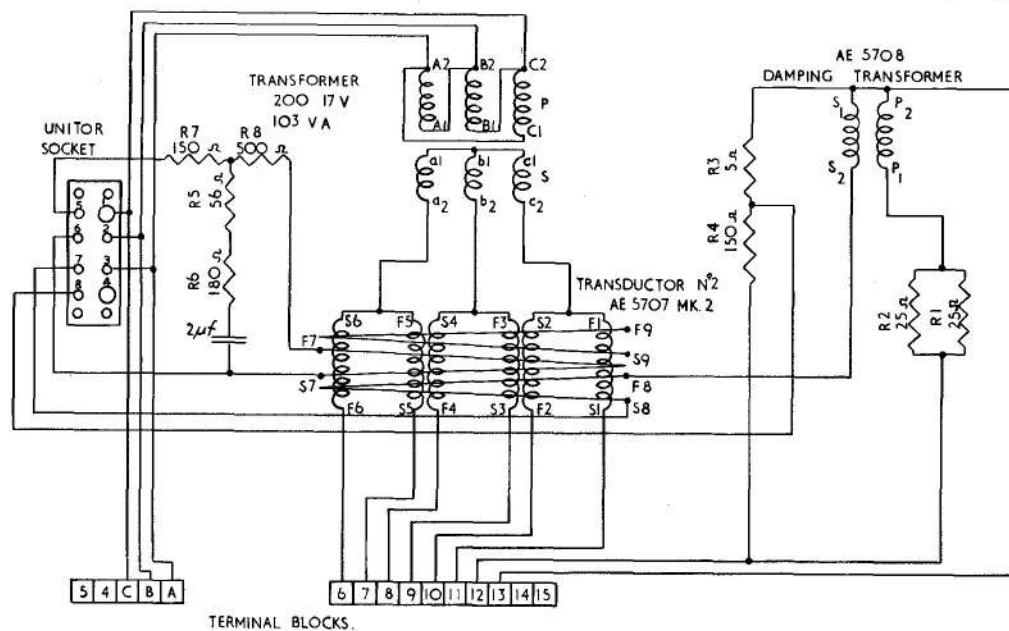

Fig.4 Wiring diagram, Type AE.7511 unit

18. The positive line is connected to a 5 k.ohm potentiometer to adjust the applied voltage to a trigger tube bridge. The striking voltage of each trigger tube is 115V maximum, and after about three minutes warming up period, the voltage across the tubes is virtually constant at 85V irrespective of current flow.

19. It will be seen that if the bridge is balanced, i.e., the voltage drop in each limb of the bridge is equal, there will be no difference in potential in the output lines to the first-stage magnetic amplifier and no current will flow. In the unit the bridge is set up so that it is slightly unbalanced at 200V, thus causing a slightly increased voltage drop across the resistors but not across the trigger tubes. These are virtually constant at 85V. From this it will be seen that with the bridge in this unbalanced condition current will flow in the output lines to the first-stage magnetic amplifier proportionate to the unbalance. This is approximately 0.5

mA under the condition imposed upon the unit.

20. The first-stage magnetic amplifier a.c. windings are supplied from a step-down transformer whose primary is connected across two lines of the generator feeders. The control winding of the magnetic amplifier is supplied from the output of the voltage reference circuit. The impedance of the main winding of this magnetic amplifier will be reduced and so an increased current will flow from this amplifier to the second-stage in the order of 26 mA.

21. The two amplifiers, connected in cascade, are coupled through an interstage filter circuit which smooths the output from the first-stage magnetic amplifier and also prevents harmonic feedback from the second stage to the first stage.

22. This second-stage magnetic amplifier has its main winding supplied by a delta-

RESTRICTED

star step-down three-phase transformer, the primary of which is connected to the generator feeders.

23. The 26 mA signal passed to the second-stage magnetic amplifier decreases the impedance of the main windings resulting in an output current flow of approximately 3 amp.

24. The output of the amplifier is connected to the quick-release terminal block and from there, through a power rectifier bridge and self-excitation rectifiers (not fitted to the units but in the electrical power system), to the junction of the exciter fields and their associated resistors. The value of this output is approximately 3 amp.

25. The current flowing from the units to the exciter fields opposes the exciter field current and adjusts itself until the excitation is correct to give a terminal voltage within the correct limits, i.e., 201/199V. between no-load and full-load conditions.

26. The method of stabilizing is dealt with in para.33.

Generator output above normal

27. In this case the same procedure applies as before except that the signal applied to the control winding of the first-stage amplifier is increased, resulting in a reduction in current flow in the exciter field windings and a consequent reduction in terminal voltage. A more detailed description of this is given in the following paragraphs.

28. A rise in voltage in the generator feeders will increase the current flow through the resistors and neon trigger tubes in the voltage reference circuit. This causes an increased voltage drop across the resistors but not across the trigger tubes. These are virtually constant at 85V.

29. From this it will be seen that the junction of the trigger tube T1 and its series resistor will become more positive and the bridge will become more unbalanced. Under this condition a potential difference is developed across the output leads to the first-stage magnetic amplifier proportional to the rise in generator terminal voltage, resulting in an increased current flow in control windings.

30. The impedance of the a.c. winding of this magnetic amplifier will be increased and so decreased current will flow in the control winding of the second-stage magnetic amplifier. This will decrease the impedance of its a.c. windings resulting in an increase in output current.

31. The output of this second-stage magnetic amplifier is passed through a power rectifier bridge (not fitted to the units but in the electrical power system) and applied to the junction of the exciter fields and their associated resistors.

32. The output of the second-stage magnetic amplifier opposes the exciter field current and therefore an increase in this output results in a weakening of the exciter field and consequent reduction in terminal voltage of the generator.

Stabilizing

33. This is in the form of feedback from the exciter to a second control winding on the second-stage magnetic amplifier. The stabilizing circuit is energised from the exciter and any rise in exciter voltage is applied to the primary of the damping transformer which causes a transient output from the transformer secondary windings. This output is applied to the second control or feedback winding within the second-stage magnetic amplifier. The current in this feedback winding flows the opposite way to that in the main winding which caused the original change in exciter voltage, thus reducing overshoot and damping any tendency to oscillate.

RESTRICTED

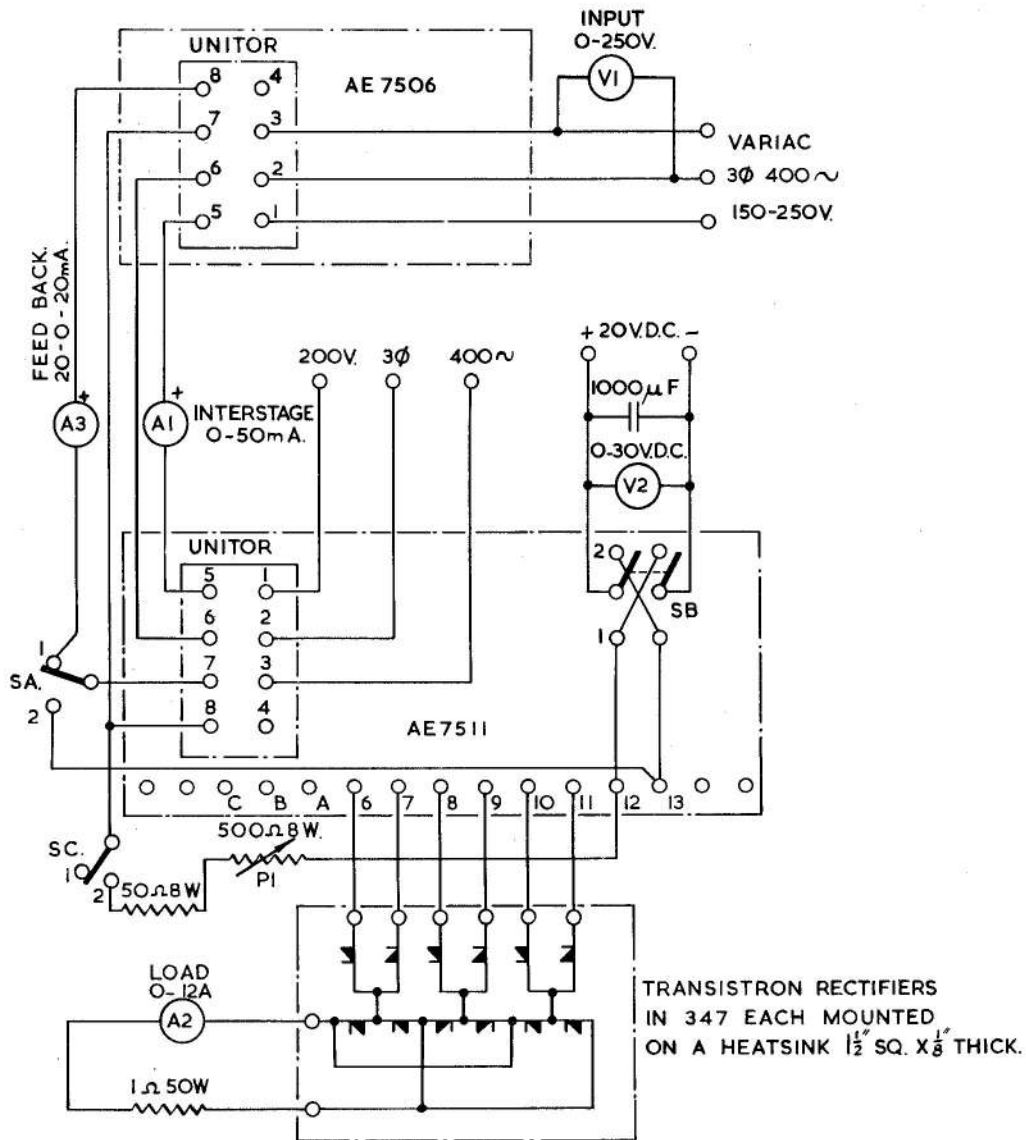

Fig.5 Test circuit

INSTALLATION

34. Normally the units are combined, the Type AE.7506 being mounted on the top of the Type AE.7511, and secured with four 4 B.A. ch/hd. screws and washers.

35. The two units are mounted in position on the aircraft through the feet provided

on the base of the Type AE.7511 unit, and secured with four 2 B.A. screws and lock-washers.

36. The electrical connections are made from the aircraft electrical system to the two quick-release terminal blocks on the Type AE.7511 unit. The smaller one housing the leads from the generator feeders.

RESTRICTED

SERVICING

37. Without removing the unit from the aircraft the only servicing necessary is routine inspection for security, mechanical damage and corrosion. There are no moving parts within the units and no internal servicing should be necessary.

TESTING

General

38. The Type 162 a.c. generator (E.E.

Type AE.2036) should be used to provide the electrical supply for all testing purposes. The line voltage should be measured with the test set, 200V, 400 c/s, 3-phase a.c. (Ref.No. 5QP/3198).

Functional test

39. Connect the unit to the test circuit, as shown in fig.5, that is with the two units separated. Where one unit is suspect, the other unit should be a slave of proven serviceability which will prove on test where the fault lies.

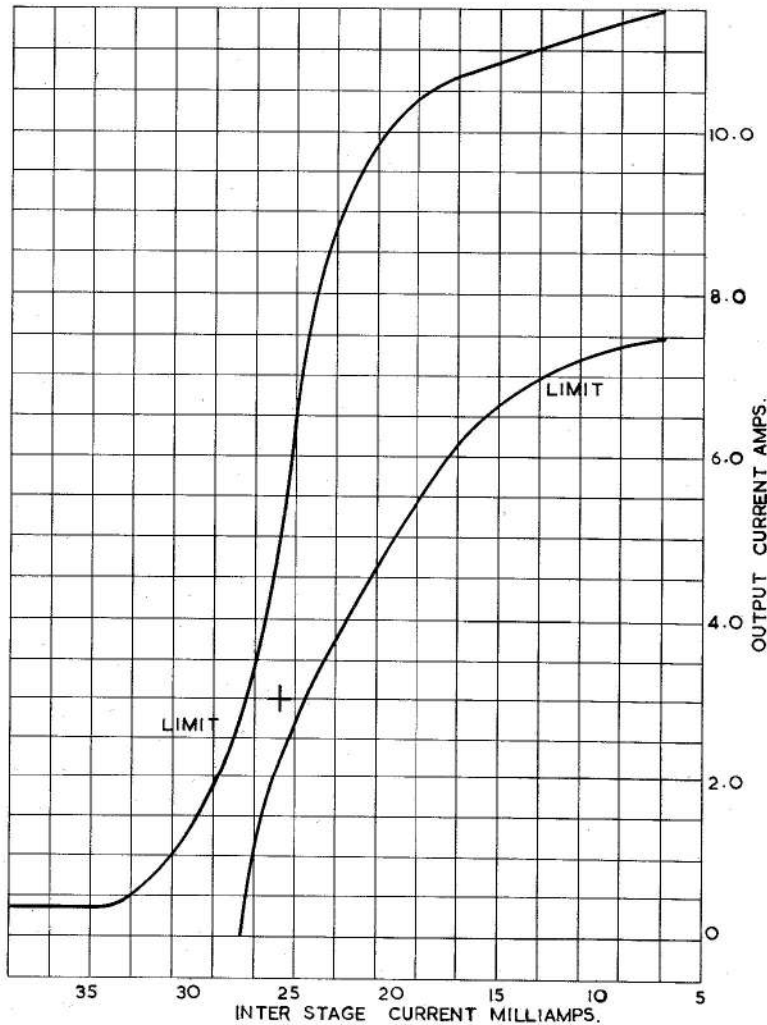

Fig.6 Characteristic curves

RESTRICTED

40. Close each of the switches Sa, Sb, Sc, to position 1 and adjust V2 to 20 volts. The feedback current A3 is to be within + 7 to + 10mA. By adjusting V1 with the variac, set the interstage current A1 to 26 mA. If the output A2 is less than 3.0 amp., close switch Sc and, using P1, increase the feedback current A3 so that the output current A2 is 3.0 amp. The required change in A3 must not be more than 9 mA. Vary the interstage current A1 over the range 5 to 40 mA in at least 10 suitable increments, taking readings of output and interstage current. The characteristic obtained is to be within the limits specified in fig.6.

Insulation test

41. With the units disconnected from the

aircraft electrical system, the insulation resistance of the unit, measured at 500 volts d.c., between all terminals and the case should be not less than 5 megohms.

Note...

The values of resistance quoted in the paragraph above apply to units being tested under normal workshop conditions. Due allowance should be made for climatic conditions of the locality, and of the aircraft servicing area, or dispersal point. In particularly damp or humid atmospheres, the reading obtained may be low enough to give apparent cause for rejection; however, in these circumstances, discretion should be exercised.

RESTRICTED

000

0

0

00

0

|

This file was downloaded
from the RTFM Library.
Link: www.scottbouch.com/rtfm

Please see site for usage terms,
and more aircraft documents.

