

Chapter 6

REGULATOR AMPLIFIER UNIT, ROTAX, TYPE U6101

LIST OF CONTENTS

	<i>Para.</i>		<i>Para.</i>
<i>Introduction</i>	1	<i>Testing</i>	
Description	4	<i>General</i>	15
<i>Operation</i>	5	<i>Continuity tests</i>	16
<i>Electrical connections</i>	12	<i>Insulation resistance test</i>	17
Installation	13	<i>Setting-up procedure</i>	18
Servicing	14	<i>Gain adjustment</i>	20
		<i>Gain test</i>	21

LIST OF TABLES

	<i>Table</i>		<i>Table</i>
<i>Circuit component details</i>	1	<i>Test circuit components</i>	2

LIST OF ILLUSTRATIONS

	<i>Fig.</i>		<i>Fig.</i>
<i>General view of Type U6101 unit</i>	1	<i>Circuit diagram</i>	4
<i>Layout of components (top cover removed)</i>	2	<i>Test circuit diagram</i>	5
<i>Layout of components (bottom cover removed)</i>	3		

LEADING PARTICULARS

Regulator amplifier, Type U6101	Ref. No. 5UC/6883
<i>Voltage regulation</i>	112V d.c. $\pm 1\frac{1}{2}$ per cent
<i>Temperature range</i>	-40 deg. C to +70 deg. C
<i>Cooling</i>	natural
<i>Operational ceiling</i>	60 000 ft. (max.)
<i>Mounting</i>	see <i>Installation</i> (para. 13)
<i>Associated equipment</i>	Carbon pile regulator, Type 120
<i>Overall dimensions:</i>					
<i>Length</i>	6.125 in. (max.)
<i>Width</i>	5.000 in. (nominal)
<i>Height (base to top of cover)</i>	3.500 in. (max.)
<i>Height (base to cover screws)</i>	3.671 in. (max.)
<i>Weight</i>	1 lb. 15 oz.

RESTRICTED

Introduction

1. The regulator amplifier unit, Type U6101 is used in conjunction with the carbon pile regulator, Type 120 to control the output of the generator, Type 551. The amplifier employs three transistors and uses two zener diodes as the reference. The action of the amplifier is to reduce any error in the generated voltage by providing an adjustment in the ampere-turns on the regulator; the ultimate reference therefore is removed from the regulator spring.

2. The carbon pile regulator differs from conventional types in having the equalizing and shunt series stabilizing coils removed and having in their place a single auxiliary coil, fed from the output of the regulator amplifier. Stabilization is obtained by feedback of the generator shunt field volts into the transistor amplifier; similarly the equalizing signal obtained from the series field volts is also fed into the amplifier. By this means, closer voltage regulation is obtained than that achieved by a conventional carbon pile regulator alone.

3. The primary object of using the transistor amplifier in conjunction with the carbon pile regulator is to improve the system stability when large dynamic loads are present on a system which has no battery. It is therefore essential that the a.c. gain of the amplifier is correctly matched to both the system response and to the carbon pile characteristics. The a.c. gain of the amplifier is therefore adjusted to give sufficient gain at 5 c/s for good system transient stability, while the gain at 200 c/s is sufficiently attenuated to ensure that local loop spring resonance cannot occur.

DESCRIPTION

4. The amplifier employs three silicon transistors, two zener diodes, two capacitors, 20 fixed resistors, one Silistor and four potentiometers, also a transistor heat sink assembly together with a terminal block and cover assembly. The chassis assembly embodies two group board assemblies, on which all the component parts are mounted within the chassis framework. Contained within the top cover are the fixed resistors, and the potentiometer lock-nuts and lock bodies; the cover is secured to hexagonal supports by four captive cheese-head screws and associated locking washers. An insulating bottom cover plate protects the transistors, diodes, capacitors and potentiometers, contained within the chassis framework, and is

secured to the base by four countersunk captive screws. The main chassis assembly embodies the four mounting feet as an integral part of the chassis; the top face incorporates the terminal block which is mounted and secured by two studs and is situated outside the top cover.

Operation

5. At normal system voltage the amplifier is adjusted by means of variable resistors RV1 and RV3, so that there is no current flowing in the auxiliary coil. The carbon pile is then doing all the regulating of the system. Two zener diodes MR1 and MR2 in series are used as the reference of the amplifier and are connected in the emitter circuit of transistor T3. An increase in line voltage results in a proportional increase in the collector current of T3, as the base current of the transistor increases from the feed through the resistors RV3 and R14.

6. From the increase in collector current of T3 an increase in the potential drop across resistor R7 results in a reduction in the current of transistor T2. Since transistors T1 and T2 are connected as a common emitter amplifier, a fall in current of T2 gives a corresponding rise in the current of T1. When this condition exists the collector potential of transistor T2 is higher than the collector potential of T1. Therefore a current will flow in the winding of the carbon pile, which is connected between the collectors of T1 and T2 so as to increase the ampere turns

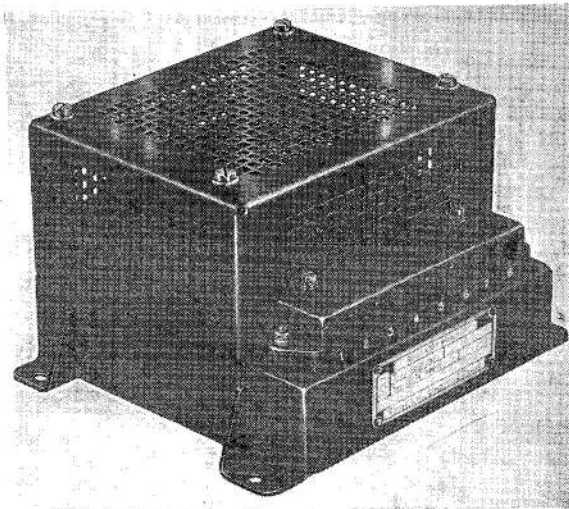

Fig. 1. General view of Type U6101 unit

RESTRICTED

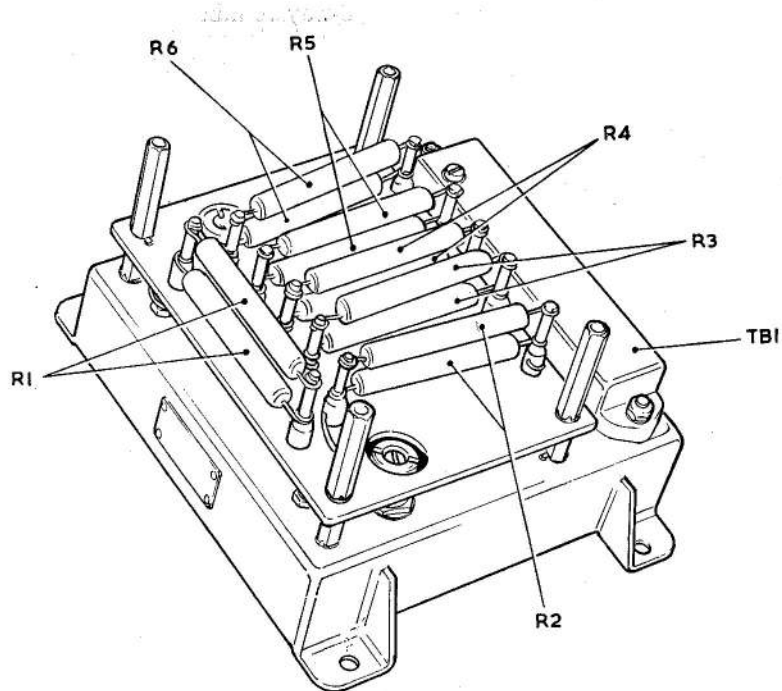

Fig. 2. Layout of components (top cover removed)

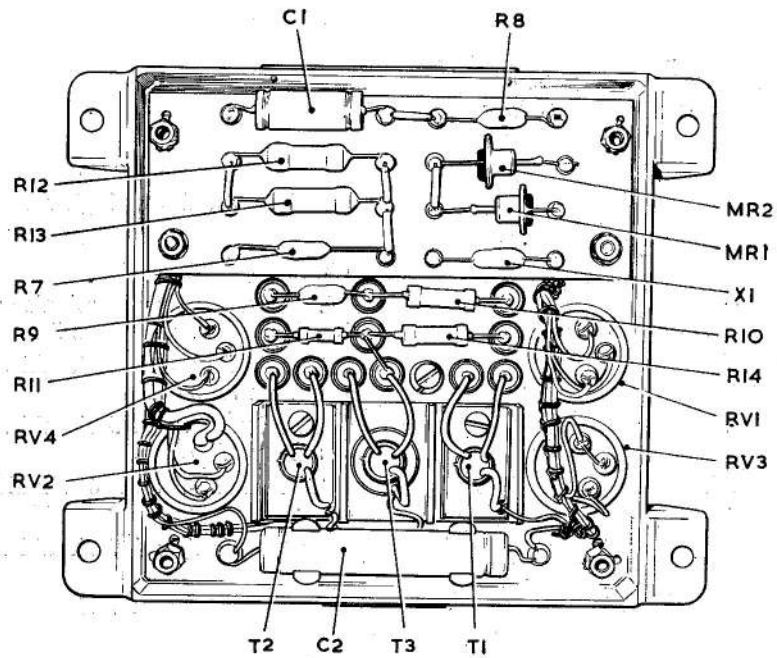

Fig. 3. Layout of components (bottom cover removed)

RESTRICTED

on the pile, with a consequent decrease in the generated voltage. Similarly, the reverse procedure takes place for a fall in the generated voltage.

7. The negative connection of the zener diode MR2 is connected to the slider of potentiometer RV2, which is connected across the series field of the generator. This is necessary to avoid a rising or falling voltage characteristic with application of load.

8. If the slider of RV2 is adjusted to the series field end of the potentiometer, the armature will continue to generate at 112 volts with increase in load, since the amplifier is sensing across the armature. However, there will be a fall in the generated terminal voltage according to the voltage drop across the series field, in this case two volts at full load.

9. If, on the other hand, the slider of RV2 is adjusted to the generator negative terminal there will be a rising voltage characteristic with application of load. This results from the fact that the negative terminal of the generator goes more positive with relation to the negative brush of the generator, with increased load, due to the voltage drop across the series field.

10. In effect, the emitter of T3 goes more positive with respect to the base of the transistor and the nett result of the amplifier is the same as an apparent fall in generated volts. The amplifier therefore reduces the ampere-turns on the pile, with the result that the terminal voltage rises with increased load. In practice, the slider of the potentiometer is adjusted to a point where the generator is unaffected by switching full load on the machine.

11. Stabilization of the system is obtained by feedback of the shunt field volts through the resistance and capacitance R11 and C2, and by the capacitor C1 connected between base and collector of transistor T3. The gain of the amplifier is adjusted by varying the potentiometer RV4 which controls the amount of negative feedback applied to the transistors T1 and T2 which are connected as a common emitter amplifier. Negative feedback is also provided to the transistor T3 by the silicon resistor X1. This silicon resistor varies with temperature and therefore provides gain compensation with temperature.

Electrical connections

12. Electrical connections are made via an 8-way terminal block, incorporating 4 B.A. terminals, numbered 1 to 8. The internal connections are shown in the circuit diagram (fig. 4).

Note . . .

Terminal No. 8 is not connected internally in the circuit.

INSTALLATION

13. The unit should be mounted in such a position as to ensure the maximum air flow in the direction of the terminal block side; the perforated sides and top of the cover should be kept well clear of any obstruction and should not be mounted closer than one inch to any blanking surface. Integral with the chassis assembly are four mounting feet provided with 2 B.A. clearance holes positioned on 4.000 in. \times 5.562 in. centres respectively.

SERVICING

14. Servicing is normally confined to ensuring that the unit is clean and free from damage, all terminal block screws and external nuts and screws should be checked for tightness. The insulation of the connecting leads should be examined for signs of fraying or deterioration and all connections should be checked to ensure that they are secure.

Testing

General

15. All soldered joints should be carefully inspected for dry or high resistance joints.

Continuity tests

16. Tests between terminals on the terminal block should be made as follows:—

Terminals 1 and 2 should show approximately 1000 ohms

Terminals 3 and 5 should show approximately 850 ohms

Terminals 4 and 6 should show open circuit

Terminals 5 and 7 should show approximately 25 ohms

Terminals 6 and 7 should show approximately 5.6 ohms

These tests should be made using an Avometer on resistance range.

RESTRICTED

RESTRICTED

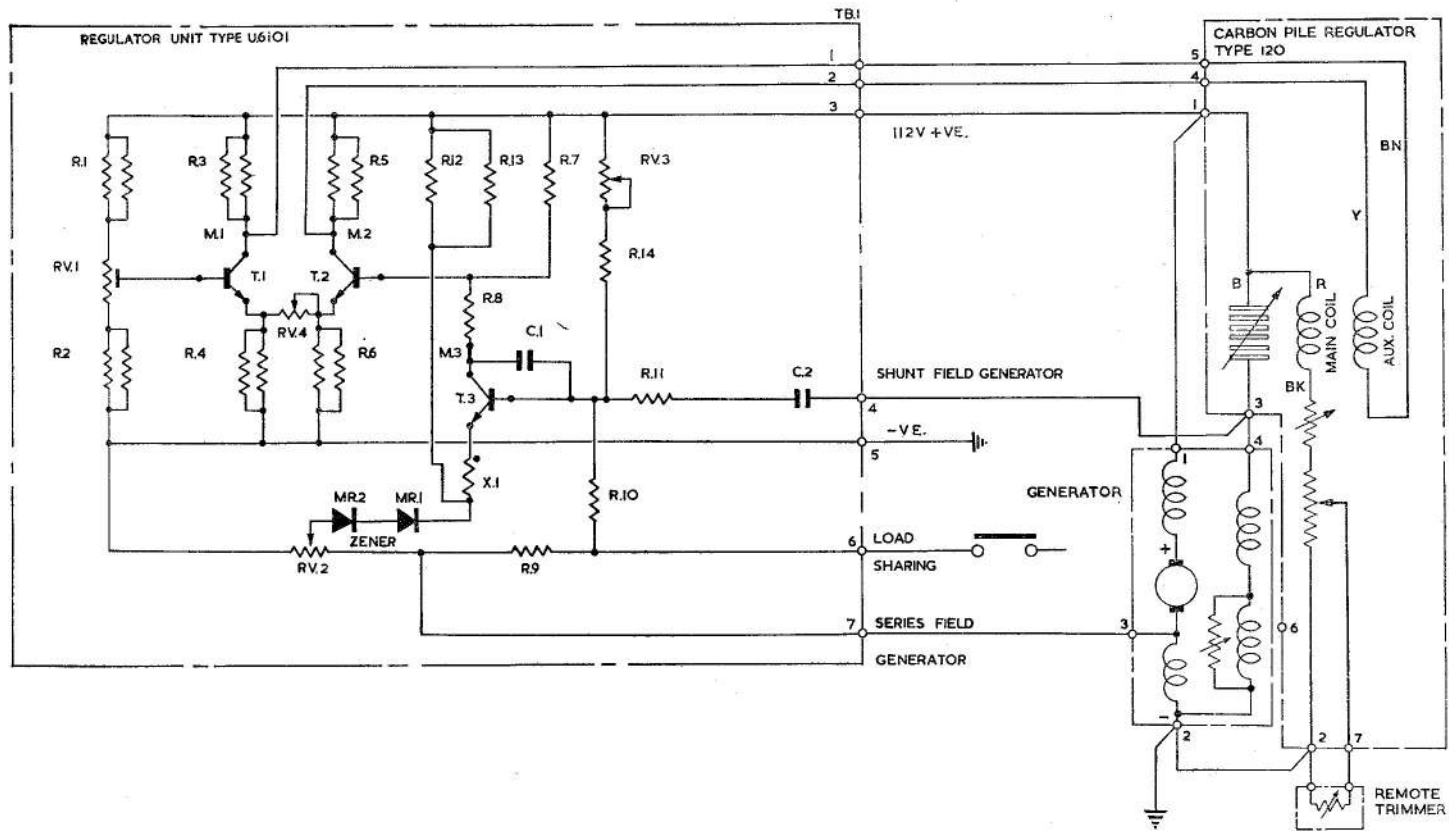

Fig. 4. Circuit diagram

Table 1
Circuit component details

Circuit Ref.	Description	Value	Rotax No.
R1	Resistor W/W 6W (2 in parallel)	1.2 K ohms	N112593/51
R2	Resistor W/W 6W (2 in parallel)	1 K ohms	N113593/49
R3	Resistor W/W 6W (2 in parallel)	1 K ohms	N112593/49
R4	Resistor W/W 6W (2 in parallel)	1 K ohms	N112593/49
R5	Resistor W/W 6W (2 in parallel)	1 K ohms	N113593/49
R6	Resistor W/W 6W (2 in parallel)	1 K ohms	N113593/49
R7	Resistor W/W 1½W	5.1 K ohms	N113590/66
R8	Resistor W/W 1½W	1.5 K ohms	N113590/53
R9	Resistor W/W 1½W	5.6 ohms	N113590/110
R10	Resistor Carbon ½W	6.8 K ohms	N151641/69
R11	Resistor Carbon ¼W	100 K ohms	N146589/97
R12	Resistor W/W 3W	10 K ohms	N113591/73
R13	Resistor W/W 3W	10 K ohms	N113591/73
R14	Resistor Carbon ½W	43 K ohms	N151641-88
RV1	Potentiometer W/W 1W	50 ohms	N145623/6
RV2	Potentiometer W/W 1W	25 ohms	N145623/4
RV3	Potentiometer W/W 1W	10 K ohms	N145623/23
RV4	Potentiometer W/W 1W	50 ohms	N145623/6
T1	Transistor	—	N151493-4
T2	Transistor	—	N151493-4
T3	Transistor	—	N151493-4
MR1	Zener diode	—	N147074-2
MR2	Zener diode	—	N147074-7
C1	Capacitor	0.1 µF	N152008-1
C2	Capacitor	8 µF	N151917-33
X1	Silistor	68 ohms	N154533-6
TB1	Terminal block	—	N143742-1

Insulation resistance test

17. The insulation resistance test should show insulation resistance of not less than 5 megohms.

Common together terminals 1, 2, 3, 4, 5, 6, and 7, and test between the commoning lead and chassis.

Note . . .

This is the only insulation resistance test to be carried out.

Setting-up procedure

18. A controlled 120V d.c. supply capable of supplying 400 mA is required for test on this unit, also a separate variable 6V d.c. supply capable of supplying 250 mA.

19. Connect the regulator amplifier in the circuit as shown in fig. 5 without connecting milliammeter A4 (Table 2).

- (1) Switch on and adjust V1 to 112 volts with S1 in position A on fig. 5.

RESTRICTED

- (2) Balance the current A1 and A2 within 2 mA of each other in the range 92.5 ± 2.5 mA. If the current is high or low when balanced, adjust RV1 to reduce or increase the current in A1 as required. Re-balance by adjustment of RV3 (repeat as necessary).
- (3) Connect ammeter A4 to meter link M3. Switch on and adjust voltage to V1 to balance the amplifier.
- (4) Adjust V2 to 4 volts.
- (5) Switch S1 to position B and observe the movement of A4. Adjust RV2 for zero change in current of A4 when alternatively switching S1 from position A to B and B to A.
- (6) Tighten potentiometer locking device RV2. Remove A4 from circuit and solder meter link M3 in place.
- (7) Switch S1 to position A and adjust V1 to 112V. Adjust current in A3 to zero by alteration of RV3; check that A1

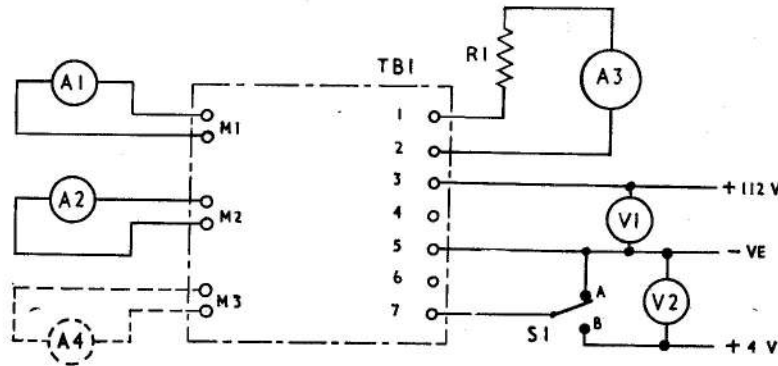

Fig. 5. Test circuit diagram

Table 2

Test circuit components

V1	150V F.S.D. moving coil voltmeter
V2	10V F.S.D. moving coil voltmeter
A1	150mA F.S.D. moving coil milliammeter
A2	150mA F.S.D. moving coil milliammeter
A3	150mA F.S.D. centre zero moving coil milliammeter
A4	15mA F.S.D. moving coil milliammeter
R1	220 ohm 1.5 watt resistor
S1	Single pole double throw switch

- (1) A controlled 50 to 120 volt d.c. supply capable of supplying 400mA.
- (2) A controlled 6 volt d.c. supply capable of supplying 250mA.
- (3) A low frequency decade oscillator capable of supplying 10V r.m.s. at 5 c/s and 200 c/s into an impedance of 100 000 ohms.
- (4) A d.c. oscilloscope with a calibrated voltage scale of 4V/cm.

RESTRICTED

and A2 are 92.5 ± 2.5 mA. Tighten potentiometer locking device for RV1.

- (8) Switch off and remove milliammeters A1 and A2 from circuit and solder meter link M1 and M2 in place.
- (9) Switch on and adjust V1 to 112 volts and leave unit for 10 minutes to warm up.
- (10) Adjust V1 to 112 ± 0.25 volts and adjust RV3 to bring A3 to zero. Tighten potentiometer locking device for RV3.

Gain adjustment

20. A low frequency decade oscillator capable of supplying 10V r.m.s. at 5 c/s and 200 c/s into an impedance of 100 000 ohms is required for these tests. A d.c. oscilloscope with a calibrated voltage scale of 4V/cm is also required.

- (1) Remove ammeter A3 from the circuit as left in para. 19. Connect the output of the decade oscillator to terminals No. 4 and No. 5.
- (2) Switch on d.c. supply and adjust V1 to 112 volts. Connect the oscilloscope to terminals 4 and 5 and adjust the output

of the oscillator to give 10 volts peak to peak on the oscilloscope (d.c. range 4V/cm) at 5 c/s.

- (3) With the oscilloscope sensitivity as in para. 19, sub-para. (2), connect it to terminals 1 and 2 so as to read the voltage swing across the 220 ohm resistor.
- (4) Adjust RV4 so that the voltage deflection across terminals 1 and 2 is 13.2 ± 1.1 volts peak-to-peak, i.e. the amplifier gain should be 6.0 ± 0.5 mA/V at 5 c/s.
- (5) Connect the oscilloscope to terminals 4 and 5, and adjust the oscillator output to 10 volts peak-to-peak at 200 c/s.
- (6) Connect the oscilloscope to terminals 1 and 2; the voltage deflection must not be greater than 2.2 volts peak-to-peak (i.e. amplifier gain is not to be greater than 1 mA/V at 200 c/s).

D.C. gain test

21. (1) Remove oscillator from terminals 4 and 5 and replace ammeter A3 in circuit.
- (2) Switch on d.c. supply, adjust to 110 volts, and note the current indicated by A3. Adjust the voltage to 114 volts; the current in A3 must have changed by 36 ± 6 mA.

RESTRICTED

This file was downloaded
from the RTFM Library.

Link: www.scottbouch.com/rtfm

Please see site for usage terms,
and more aircraft documents.

