

*Cancelled*  
*Now 113D-07124-1*

**Chapter 8**

**VOLTAGE REGULATOR TYPE 122  
 (E.E. Type AE.7301)**

**LIST OF CONTENTS**

	<i>Para.</i>		<i>Para.</i>
<i>Introduction</i> ... ..	1	<i>Stabilizing</i> ... ..	18
<b>Description</b>		<b>Servicing</b> ... ..	19
<i>General</i> ... ..	2	<b>Testing</b> ... ..	20
<i>Voltage reference circuit...</i> ... ..	4	<i>Wiring check</i> ... ..	21
<i>Reactive load sensing circuit</i> ... ..	6	<i>Test of reactive load sensing circuit using inductive load</i> ... ..	22
<i>First stage magnetic amplifier</i> ... ..	7	<i>Test of reactive load sensing circuit using non-inductive load</i> ... ..	23
<i>Second stage magnetic amplifier...</i> ... ..	8	<i>Voltage regulation test</i> ... ..	24
<b>Operation</b>		<i>Insulation test</i> ... ..	25
<i>Generator output voltage constant at 200V</i> ... ..	9		
<i>Out of balance reactive load condition</i> ... ..	13		
<i>Generator overvolting</i> ... ..	17		

**LIST OF ILLUSTRATIONS**

	<i>Fig.</i>		<i>Fig.</i>
<i>Voltage regulator, Type 122</i> ... ..	1	<i>Reactive load sensing circuit</i> ... ..	4
<i>Underside view of panel assembly</i> ... ..	2	<i>Wiring diagram</i> ... ..	5
<i>Topside view of panel assembly</i> ... ..	3	<i>Test circuit</i> ... ..	6

**LEADING PARTICULARS**

<i>Voltage regulator, Type 122</i> ... ..	<i>Ref. No. 5UC/6884</i>
<i>Line voltage</i> ... ..	<i>200 V, r.m.s. ± 2½% over the full environmental range</i>
<i>Line frequency</i> ... ..	<i>400 c/s ± 1%</i>
<i>Phases...</i> ... ..	<i>Three</i>
<i>Output (to main exciter)</i>	
<i>Normal</i> ... ..	<i>2.75 A. d.c.</i>
<i>Range</i> ... ..	<i>0.3 to 8A</i>
<i>Load sharing</i> ... ..	<i>within 5 kVAR under all load and input speed changes</i>
<i>Rating...</i> ... ..	<i>Continuous</i>
<i>Cooling</i> ... ..	<i>Natural</i>
<i>Maximum altitude</i> ... ..	<i>65,000 ft.</i>
<i>Temperature range</i> ... ..	<i>-65°C to +70°C</i>
<i>Weight</i> ... ..	<i>10.5 lb.</i>

**RESTRICTED**

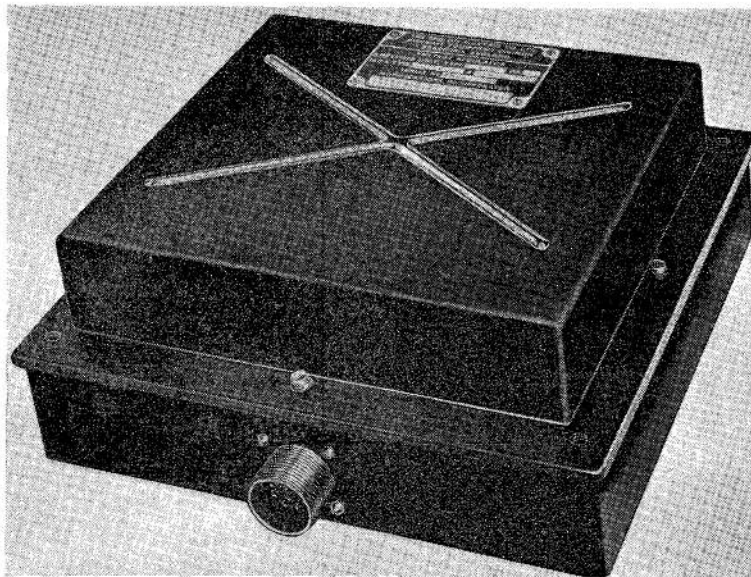

Fig. 1. Voltage regulator, Type 122

### Introduction

1. The voltage regulator Type 122 is designed to control the voltage output of a generator within close limits as given in Leading Particulars. It is intended for use with brushless a.c. generators, both air-cooled and oil-cooled, and may be used in single or multi-generator a.c. systems. The unit is totally enclosed between two containers, the cover and the box assembly. The box assembly provides four holes in the corners, for mounting the unit to the airframe.

### DESCRIPTION

#### General

2. The panel assembly comprises the main electrical components of the unit, with a steel panel as the base; it accommodates all the electrical components comprising the unit. The physical layout of the components is shown in figs. 2 and 3, they may be identified by the code symbols given in the key to the wiring diagram (fig. 5). The assembly is mounted on the lower container, so that on removal of the cover access is gained to components on the topside of the panel assembly. To expose the components fitted to the underside of the panel, the lower container must be removed.

3. The electrical circuit has four stages, the voltage reference and reactive load sensing stage, two magnetic amplifier stages, and a

power bridge rectifier output stage. The connections from the generator feeders via pins A, B and C in the Plessey UK-AN connector, are made to the voltage reference circuit via a full wave bridge rectifier encapsulation.

#### Voltage reference circuit

4. The three-phase bridge rectifier, wholly encapsulated (E1) are positioned on the underside of the panel at the end of a series of a bank of six encapsulations similar in size and shape. Situated next to the three-phase bridge encapsulation and in the same bank, is a resistor and capacitor encapsulation (E2) containing a capacitor, and two resistors Resistor R1-R6 are all contained in another encapsulation (E7) cylindrical in shape and secured to the topside of the panel with two half-circle clips. The resistor R1, R2, R4 and R5 form two limbs of a bridge arrangement, with two neon trigger tubes providing the other two limbs. This is the voltage reference stage and determines the magnitude and direction of current flow in one d.c. control winding of the first stage magnetic amplifier.

5. To complete the voltage reference circuit a potentiometer P1, which presets the signal to the resistance trigger tube bridge, and a temperature compensating coil, are placed in series in the positive line from the three-phase rectifier bridge. The output from the voltage

RESTRICTED

reference stage is passed through two series resistors, to supply the control winding of the first stage magnetic amplifier. The function of the series resistors is to control the gain and time constants of the amplifier.

**Reactive load sensing circuit**

6. A further control winding is supplied from the reactive load sensing circuit, which in conjunction with an external current transformer network, senses any change in reactive load within the system. The transformer T1, which is wholly encapsulated, is situated on the underside of the panel immediately underneath the other transformer (T2) fitted to the topside of the panel. Included in this encapsulation are two silicon diodes which act as demodulating rectifiers. Resistor R9, a wire-wound type,

secured to the inderside of the panel with a 4 B.A. screw, is the load resistor for the load sharing current transformer network. This, in conjunction with the potential divider P2, supplies the out of balance signal to charge capacitors C2 and C4. The output from the capacitors is the signal applied to the second control winding of the first stage magnetic amplifier. The two capacitors C2 and C4 are tantalytic types mounted on a preformed bracket on the underside of the panel and adjacent to the encapsulated transformer T1.

**First stage magnetic amplifier**

7. Reference should be made to A.P.4343, Vol. 1, Sect. 1, Chap. 3, for general and technical information on Magnetic Amplifiers. The main supply to the first stage magnetic amplifier is from the generator

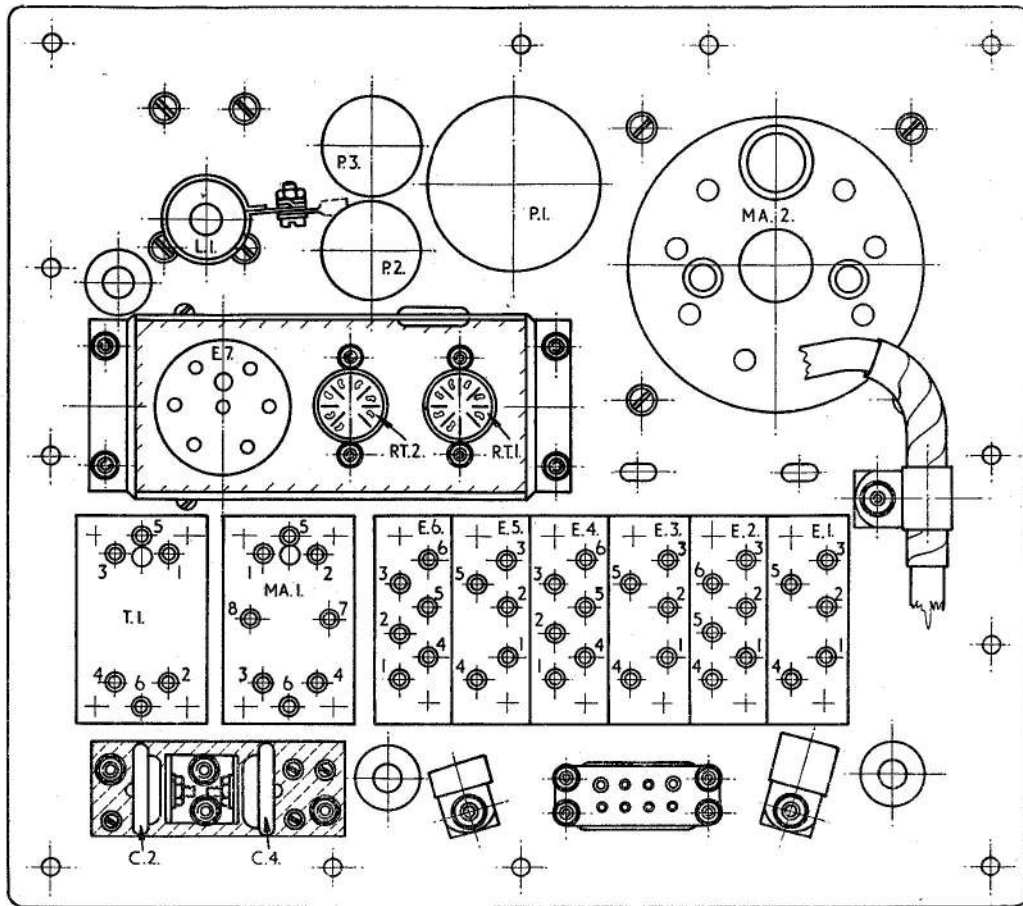

Fig. 2. Underside view of panel assembly

**RESTRICTED**

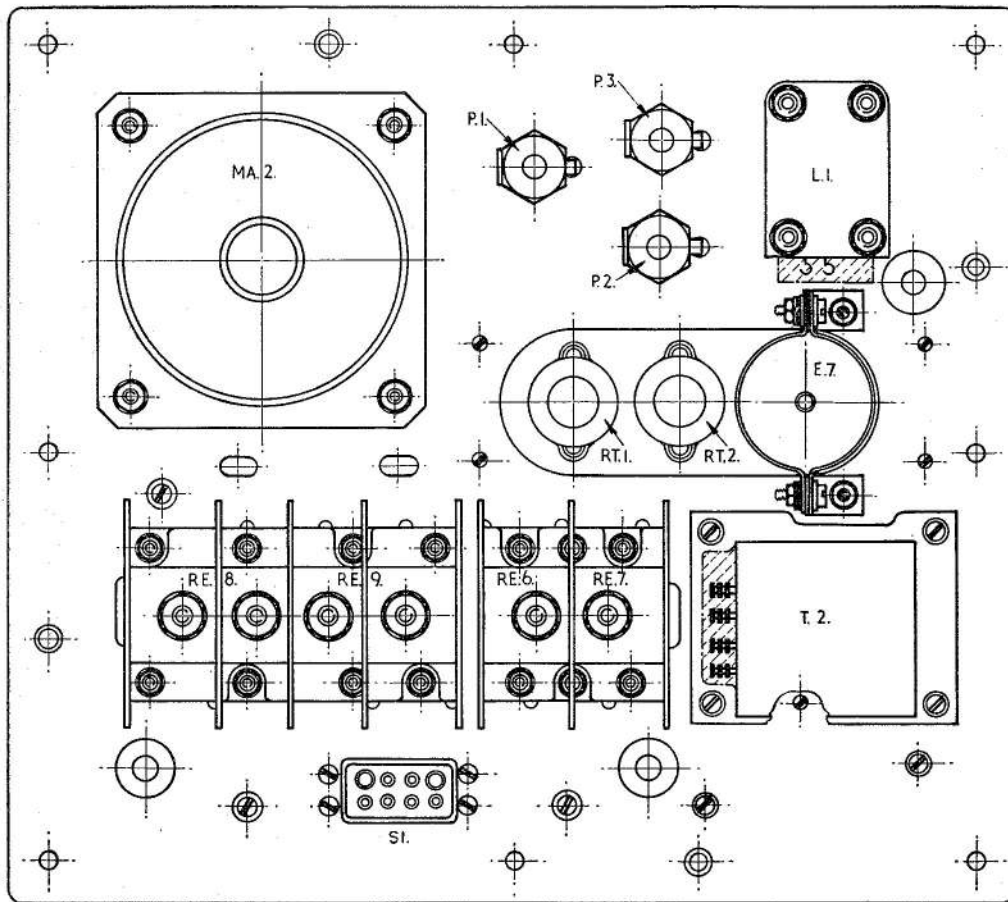

Fig. 3. Topside view of panel assembly

pilot exciter, and the two control windings receive their signals from the voltage reference and the load sensing circuits. Transformer T2, which is a stabilizing transformer to obviate hunting, is fitted to the topside of the panel adjacent to the cylindrical resistor encapsulation (E7). The transformer senses any change in main exciter field current and induces a secondary signal proportionate to the rate of this change. This signal is applied to the second control winding of the first stage magnetic amplifier but in the opposite sense to the signal effecting the change; thus damping the action of the magnetic amplifier. A means of adjusting this signal is provided in potentiometer P3. Interstage coupling is provided between the first and second stage magnetic amplifiers, in the form of a resistor-capacitor filter network. This consists of capacitor C3 and resistors R14 and 15, all encapsulated (E3)

and fitted to the underside of the panel adjacent to the resistor and capacitor encapsulation (E2).

#### Second stage magnetic amplifier

8. The main supply to this magnetic amplifier is from the same source as that of the first stage amplifier, namely the generator pilot exciter. Rectifiers RE6 and RE7 are contained in a heat sink bracket to dissipate the heat. This is fitted to the topside of the panel next to the damping transformer T2. The resistor R16 is contained within the interstage coupling encapsulation E3 and is electrically connected in parallel with RE6 and RE7 to stabilize the action of the amplifier. The bridge rectifiers RE8 and RE9 are fitted next to the RE6 and RE7 rectifiers in the same heat sink on the topside of the panel. RE8, RE9, RE10, and RE11 form the bridge for the final output stage of

**RESTRICTED**

the unit, supplying the generator main exciter via the UK-AN connector.

### OPERATION

#### Generator output voltage constant at 200V

9. The generator feeders are tapped and the resulting supply fed to the full wave bridge rectifiers via pins A, B, C, on the UK-AN connector. The rectified output of approximately 265V is applied to the smoothing circuit consisting of series resistor R6, and capacitor C1 which is connected across the two lines. The smoothing circuit causes a voltage drop in the order of 45V. In series with the resistor R6 is potentiometer P1 which provides the means of adjusting the applied voltage to the trigger tube bridge. The striking voltage of each trigger tube is 115V maximum, and after about three minutes warming up period the voltage across the tubes is virtually constant at 85V irrespective of current flow.

10. If the bridge is balanced, i.e. the voltage drop in each limb of the bridge is equal, no current will flow from the voltage reference stage to the first stage magnetic amplifier. In the unit the bridge is slightly unbalanced at 200V output from the generator, thus causing a slight voltage drop across the resistors but not across the trigger tubes. This unbalance will result in a slight current flow through one control winding of the first stage magnetic amplifier.

11. Consider a magnetic amplifier to be a variable impedance, the current flowing in the control windings will vary this impedance according to the magnitude and direction of the control current. Therefore the output from the voltage reference and/or reactive load sensing circuits will vary the impedance of the first stage magnetic amplifier causing less or more current to flow to the second stage. The main windings of the first stage magnetic amplifier are supplied from the generator pilot exciter at a frequency of 1600 c/s. This supply is rectified via RE4 and RE5.

12. The two amplifiers, connected in cascade, are coupled through an interstage filter circuit which smooths the output from the first stage magnetic amplifier, and also prevents harmonic feedback from the second stage. As with the first stage, the main windings of the stage are supplied from the generator pilot exciter at 1600 c/s. One control winding of the second stage magnetic amplifier is supplied via a full wave bridge rectifier RE12 from the pilot exciter. This rectified supply is passed through the series resistors R8 and R13 to bias the magnetic amplifier within working limits. The other control winding of the second stage magnetic amplifier is supplied with a signal from the first stage magnetic amplifier. This varies the impedance, and the output, due to the gain of the two stages and provides the necessary excitation for the generator main exciter.

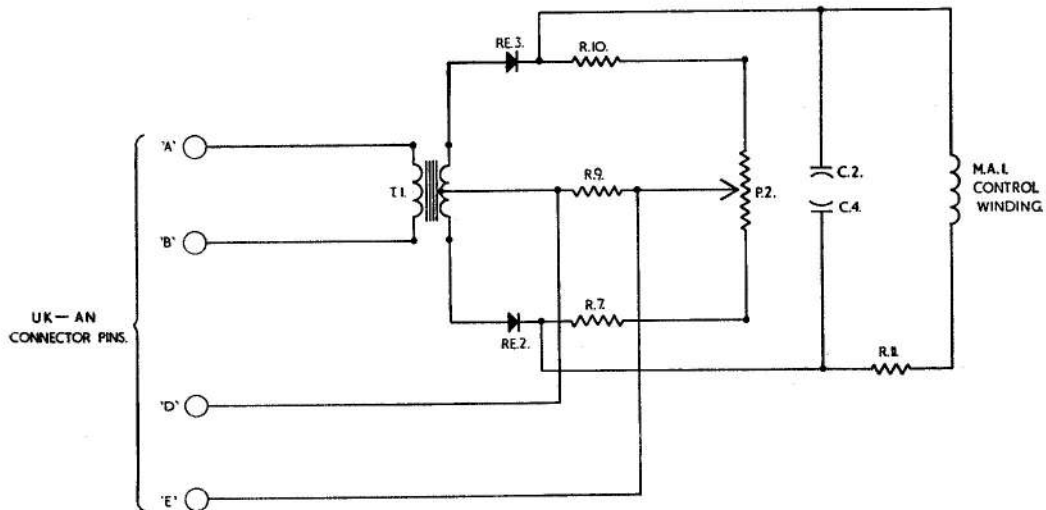

Fig. 4. Reactive load sensing circuit

**RESTRICTED**

RESTRICTED

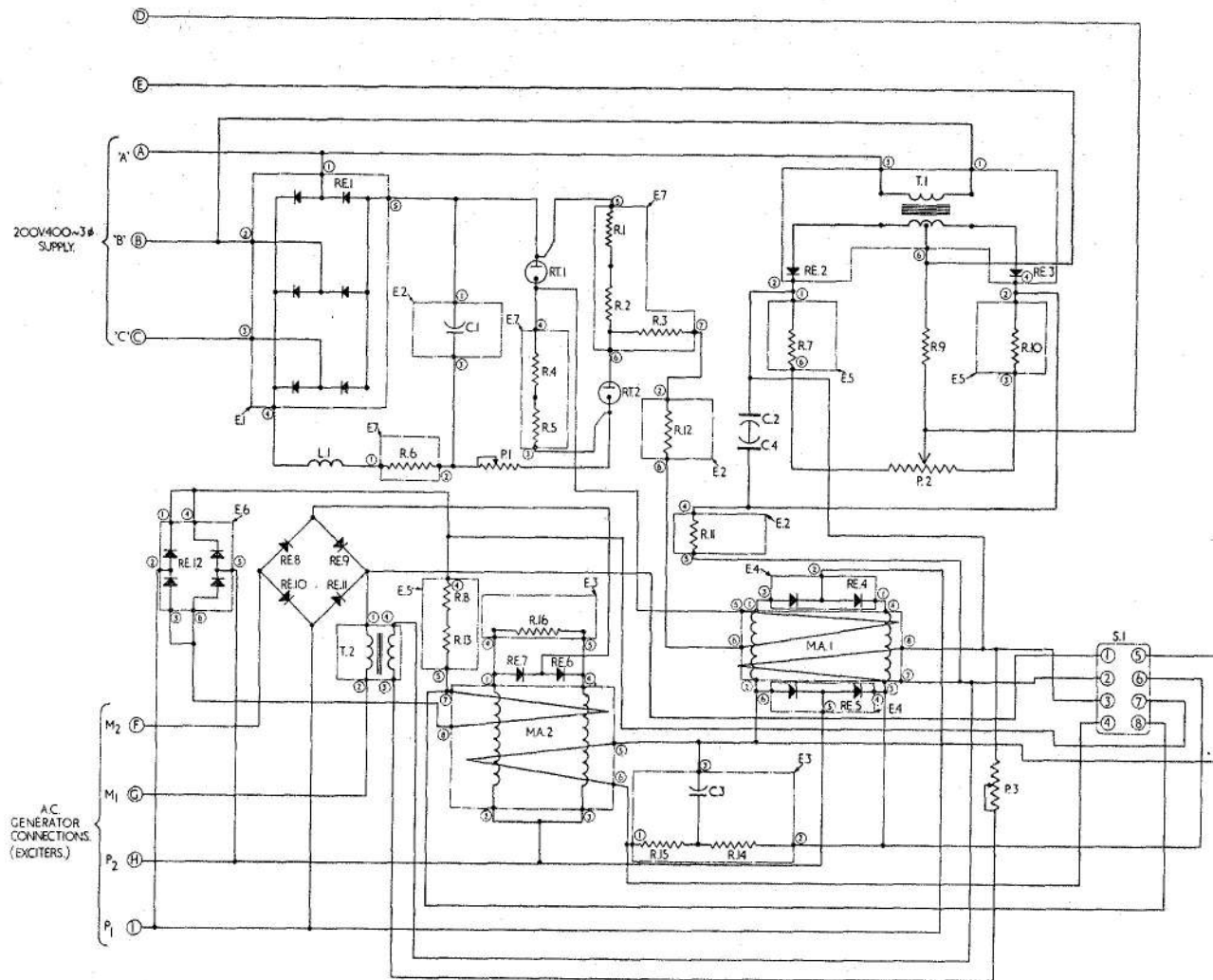

Fig. 5. Wiring diagram

## Key to Fig. 5

C.1	CAPACITOR 0.25 MFD.
C.2	CAPACITOR 50 MFD.
C.3	CAPACITOR 0.25 MFD.
C.4	CAPACITOR 50 MFD.
E.1	THREE-PHASE BRIDGE ENCAPSULATION
E.2	RESISTOR AND CAPACITOR ENCAPSULATION
E.3	FILTER ENCAPSULATION
E.4	RECTIFIER ENCAPSULATION
E.5	RESISTOR ENCAPSULATION
E.6	RECTIFIER ENCAPSULATION
E.7	RESISTOR ENCAPSULATION
L.1	TEMPERATURE COMPENSATING COIL
M.A.1	1st STAGE MAGNETIC AMPLIFIER
M.A.2	2nd STAGE MAGNETIC AMPLIFIER
P.1	POTENTIOMETER 5 K $\Omega$
P.2	POTENTIOMETER 500 $\Omega$
P.3	POTENTIOMETER 1 K $\Omega$
R.1	RESISTOR 7.5 K $\Omega$
R.2	RESISTOR 7.5 K $\Omega$
R.3	RESISTOR 10 K $\Omega$
R.4	RESISTOR 7.5 K $\Omega$
R.5	RESISTOR 7.5 K $\Omega$
R.6	RESISTOR 3.9 K $\Omega$
R.7	RESISTOR 1.2 K $\Omega$
R.8	RESISTOR 350 $\Omega$
R.9	RESISTOR 20 $\Omega$
R.10	RESISTOR 1.2 K $\Omega$
R.11	RESISTOR 4.7 K $\Omega$
R.12	RESISTOR 4.7 K $\Omega$
R.13	RESISTOR 350 $\Omega$
R.14	RESISTOR 330 $\Omega$
R.15	RESISTOR 330 $\Omega$
R.16	RESISTOR 100 $\Omega$
RE.1	SILICON GLASS DIODE TYPE IS.115
RE.2	SILICON DIODE TYPE ZS.20B
RE.3	SILICON DIODE TYPE ZS.20B
RE.4	SILICON DIODE TYPE ZS.21
RE.5	SILICON DIODE TYPE ZS.21
RE.6	SILICON DIODE TYPE ZR.22
RE.7	SILICON DIODE TYPE ZR.22R
RE.8	SILICON DIODE TYPE ZR.22R
RE.9	SILICON DIODE TYPE ZR.22
RE.10	SILICON DIODE TYPE ZR.22R
RE.11	SILICON DIODE TYPE ZR.22
RE.12	SILICON DIODE TYPE ZS.21
R.T.1	VOLTAGE REFERENCE TUBE
R.T.2	VOLTAGE REFERENCE TUBE
S.1	UNITOR SOCKET
T.1	TRANSFORMER
T.2	DAMPING TRANSFORMER

## Out of balance reactive load condition

13. In this circuit the potential divider P2 is connected to the secondary of transformer T1 via the ballast resistor R7 and R10 as shown in fig. 4. The transformer primary is connected across lines A and B of the generator feeders via pins A and B of the UK-AN connector. The electrical centre of P2 is connected to the centre tapping of this transformer through the load resistor R9. The current transformer, which is used to sense any out of balance reactive load in one line of the generator, is connected across this load resistor.

14. Initially ignoring any effect by the current transformer, for each half-cycle it will be seen that current may flow in one loop but will be blocked by the rectifier in the other loop. It follows then, that potentials of 30 volts produced across each half of P2 for each cycle will be equal and opposite, and that the net voltage appearing across capacitors C2 and C4 will be zero. Thus no current will flow in the associated control winding of the first stage magnetic amplifier.

15. Consider now the effect of the current transformer connected across the load resistor R9, the current flowing from it will produce a voltage across R9. With the primary of transformer T1 tapped into the generator feeders A and B and the current transformer connected in line C, the voltage produced across R9 will be in phase with that produced by transformer T1. Thus only reactive load is sensed and real load has virtually no effect upon the sensing circuit.

16. Assume the voltage produced across R9 to be 3 volts. Depending upon which direction the current is flowing in the current transformer the 3 volts applied will be added to the voltage of one loop and subtracted from the voltage of the other. For a complete cycle then, a voltage will appear across the capacitors C2 and C4 approximately equal to  $\sqrt{2} \times$  the difference between voltages, that is,  $\sqrt{2} (33-27) = 8.5V$ . This output from the reactive load sensing circuit is applied to the other control winding of the first stage magnetic amplifier causing an increase or decrease in the magnetic amplifier output.

## Generator overvolting

17. If the generator overvolts but not sufficiently to throw it off line, the unit will

RESTRICTED

function in the following manner. An increase in generator output voltage will result in a positive increase of reference stage output current. This has the desired effect of reducing the first and second stage magnetic amplifier outputs, and thus the main exciter field current. The subsequent result of this is a reduction of generator output voltage to thin operational limits. For a decrease in generator output voltage the action is the opposite of the foregoing.

#### Stabilizing

18. Stabilizing or damping is achieved through a form of negative feedback provided by a transformer in the output to the generator main exciter field. The transformer, induces a secondary signal when any change in primary current occurs. The feedback signal is passed to a first stage control winding in opposite sense to the signal effecting the change, thus damping any tendency to oscillate.

#### SERVICING

19. Servicing of this unit will normally be restricted to the checking of electrical connections for security, and the inspection of components to see that no damage or corrosion is apparent. The unit should be removed for Bay Servicing at the periods specified in the appropriate servicing schedule. The method of manufacture, design and

construction of the components in the unit does not readily admit to repair; any component found to be defective should be replaced with a new serviceable item.

#### TESTING

20. The a.c. generator Type 168 (E.E. Type AE.2046) should be used as the power supply for testing. The voltmeters and ammeters required for the test circuit (fig. 6) are as follows:—

Voltmeter V1 should have a range of 160-270 volts at 400 c/s and must be accurate to  $\pm 1\frac{1}{2}$  volts

Voltmeter V2 should have a range of 30-70 volts at 1600 c/s and must be accurate to  $\pm 1$  volt

Ammeter A1 should have a range of 0-5A at 400 c/s and must be accurate to  $\pm 0.1$ A.

Ammeter A2 should have a range of 0-10A, d.c. and must be accurate to  $\pm 0.05$  A.

#### Wiring check

21. Check the wiring by connecting a low voltage d.c. resistance meter across the

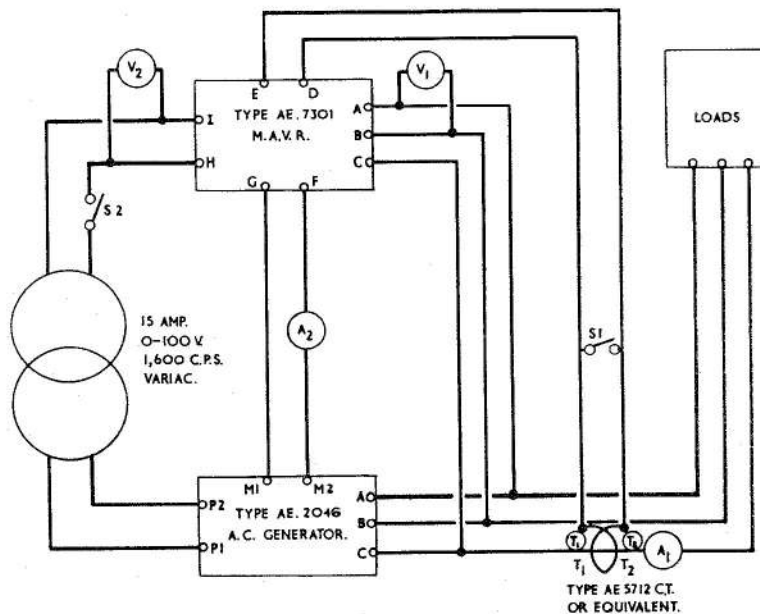

Fig. 6. Test circuit

**RESTRICTED**

following terminals, and check that the results are within the limits quoted

Terminals	Resistance value
A-B	162 $\pm$ ohms
A-C	not less than 47 kilohms
B-C	not less than 47 kilohms
A-D	not less than 10 megohms
A-H	not less than 10 megohms
H-D	not less than 10 megohms

#### Test of reactive load sensing circuit using inductive load

22. With the generator Type 168 operating at a speed of 6,000 rev/min, voltage V1 will be regulating at  $202 \pm 1.5$  volts. The variac should be adjusted to 54 volts precisely, indicated by voltmeter V2. Switch on a 25 kVAR (lag) load, open switch S1 and check that the value of V1 is between 185 and 175 volts. Repeat this test with a 15 kVAR (lag) load. The value of V1 should be between 194 and 186 volts.

#### Test of reactive load sensing circuit using non-inductive load

23. Repeat the procedure of the previous test with a load of 25 kW. The change in voltage, indicated on V1, when S1 is opened should not exceed 3 volts.

#### Voltage regulation test

24. Record the line voltage under the following load conditions. N.L., 12.5, 25, 37.05, 50, 37.5, 25, 12.5. N.L., kVA at 0.75 pf. lag and at 50 kW. The line voltage should remain within  $201 \pm 2.5$  volts and the voltage at N.L. must be  $202 \pm 1.5$  volts. Check that the line voltage does not fall to a value less than 196 volts when loaded to 60 kVA at 0.75 p.f.

#### Insulation resistance test

25. Measure the insulation resistance at 500V, d.c. after 15 seconds electrification between the following points:—

- (1) All plug pins shorted together and the case
- (2) plug pins A.B. and C. shorted together and plug pins D. and E. shorted together.
- (3) plug pins A.B. and C. shorted together and plug pins F.G.H. and I. shorted together.
- (4) Plug pins D. and E. shorted together and plug pins F.G.H. and I. shorted together.

For all tests the values obtained should be not less than 5 megohms.

**RESTRICTED**

( ) ( )

( )

( )

( )

( )

This file was downloaded  
from the RTFM Library.

Link: [www.scottbouch.com/rtfm](http://www.scottbouch.com/rtfm)

Please see site for usage terms,  
and more aircraft documents.



LIGHTNING MK. 1  
COVER PITOT HEAD  
EB2-88-511