

Chapter 9

VOLTAGE REFERENCE UNIT, ROTAX, TYPE U3606/1

LIST OF CONTENTS

	Para.		Para.
Introduction	1	Testing	
Description	2	General	13
Operation	4	Continuity tests	14
Installation	10	Insulation resistance test	15
Electrical connections	11	Performance test	16
Servicing	12		

LIST OF TABLES

	Table
<i>Circuit component details</i>	1

LIST OF ILLUSTRATIONS

	Fig.		Fig.
<i>General view of Type U3606/1</i>	1	<i>Layout of components (bottom cover removed)</i>	3
<i>Layout of components (top cover removed)</i>	2	<i>Circuit diagram</i>	4

LEADING PARTICULARS

Voltage reference unit, Type U3606/1	Ref. No. 5UC/6855
Voltage	100V d.c.
Pull-in voltage	102V $\begin{matrix} +3V \\ -2V \end{matrix}$ d.c.
Load current	60 mA $\begin{matrix} +10 \\ -15 \end{matrix}$ mA
Reduced supply voltage	94V \pm 2V with load current less than 0.5 mA
Rating (maximum permissible current)	70 mA
Altitude rating	60,000 ft. (max.)
Ambient temperature range	-40 deg. C to +70 deg. C.
Overall dimensions—	
Length	3.562 in.
Width	3.000 in.
Height	4.218 in.
Weight	14 oz.

RESTRICTED

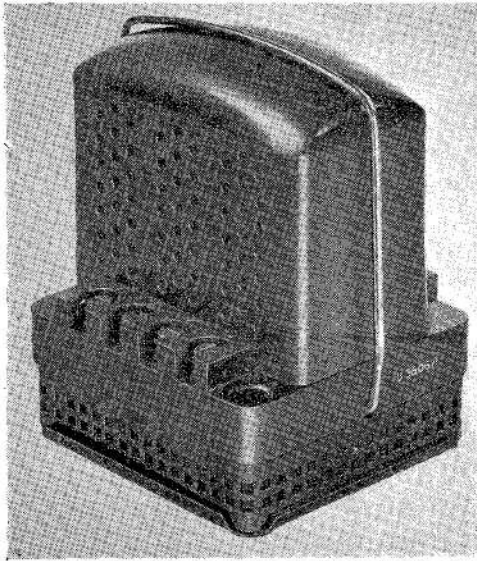

Fig. 1. General view of Type U3606/1

Introduction

1. The unit (*fig. 1*) is designed for use on a 112-volt d.c. aircraft electrical system to initiate automatically the transfer of a single bus-bar load from its generator to a pair of paralleled generators and their bus-bar when the single generator voltage falls to a value of 94 ± 2 volts. The circuit also prevents the manual transfer of the single bus-bar from the paralleled generators until the single generator voltage rises to $102 \begin{smallmatrix} +3 \\ -2 \end{smallmatrix}$ volts. The unit therefore operates both as an under-speed and under voltage relay. A transistorized trigger circuit is employed and the current available at the output terminals is adequate for the operation of a standard 12-volt, 180-ohm relay such as that embodied in relay type F7401. Transient feedback is utilized to avoid nuisance tripping of the relay.

DESCRIPTION

2. A moulded base supports an insulated plate on which are mounted the two transistors, four zener diodes and a capacitor (*fig. 2*). Above these, supported on four pillars, is a metal plate carrying the two pre-set potentiometers and four small resistors. The complete assembly is protected by a ventilated moulded cover which is held in place by a wire clip.

3. The five higher wattage resistors are contained in a ventilated compartment fixed

below the moulded base (*fig. 3*). Provision is made for the two unit fixing bolts to pass through tubes built into the corners of this lower compartment. Access to these resistors is gained by removing the two lower compartment retaining screws from the base. The circuit component details will be found in Table 1 of this chapter.

Operation

4. Terminals 1 (negative) and 2 (positive) are connected to the generator output. Terminals 3 and 4 are connected to the coil of the associated relay (*fig. 4*). As the voltage across the potential divider network between terminals 1 and 2 increases, the base potential of transistor T1 is maintained positive with respect to the emitter. T1 therefore passes more current with increase in supply voltage. Due to the voltage drop in resistors R2 and R3, the base/emitter potential of transistor T2 is reduced to such an extent that T2 is switched "hard off".

5. When the supply voltage reaches 100 volts, the zener diode sensing bridge provides a signal to the base of transistor T1 which results in a reduction of the collector and emitter currents. This reduction in current causes a drop in potential across resistors R2 and R3, and has the effect of increasing the base/emitter potential of transistor T2 which starts to conduct.

6. As the current in T2 and hence resistor R3 increases, the emitter potential of transistor T1 is driven more positive with the result

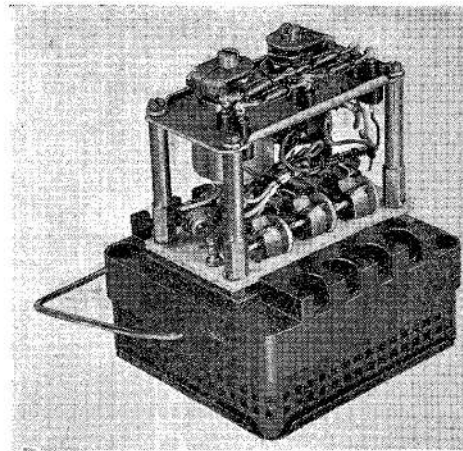

Fig. 2. Layout of components (top cover removed)

RESTRICTED

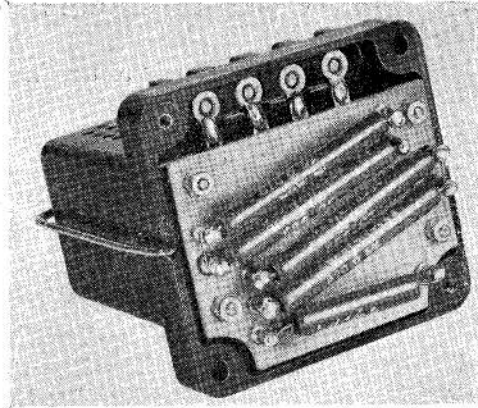

Fig. 3. Layout of components (bottom cover removed)

that T1 tends to be cut off. Transistor T2, however, is tending to go harder on as the current in R2 is falling and the base potential of T2 is going more positive. This action is cumulative and results in a definite trigger switching action. A similar action occurs when the supply voltage drops to 96 volts. Transistor T2 switches "hard off" and T1 switches "hard on".

7. The zener reference diodes, MR1 to MR4, form one arm of the voltage sensing bridge and provide a stabilized voltage for the

transistors, providing protection from over-voltage surges. MR1 and MR2 have opposite temperature co-efficient characteristics to MR3 and MR4, thus effecting temperature compensation for the circuit.

8. The potentiometers RV1 and RV2 provide adjustment of pick-up and drop-out voltages respectively, while R6 to R9 are incorporated to effect power dissipation. Capacitor C1 prevents nuisance tripping of the relay by utilizing transient feed back to effect a short time delay in the transient operation (fig. 4).

9. The value of the time delay should not be less than 20 milliseconds and not greater than 40 milliseconds for a drop of 40 per cent from a given voltage (i.e., for a drop in voltage from 100 volts to 60 volts), the time taken from the application of undervoltage to the operation of the relay should not be less than 20 milliseconds and not greater than 40 milliseconds.

INSTALLATION

10. The unit may be mounted in any attitude by means of two fixing holes, 0.193 in. diameter, situated in diagonally opposed corners of the base and corresponding to fixing centres of 2.718 in. and 2.500 in. respectively.

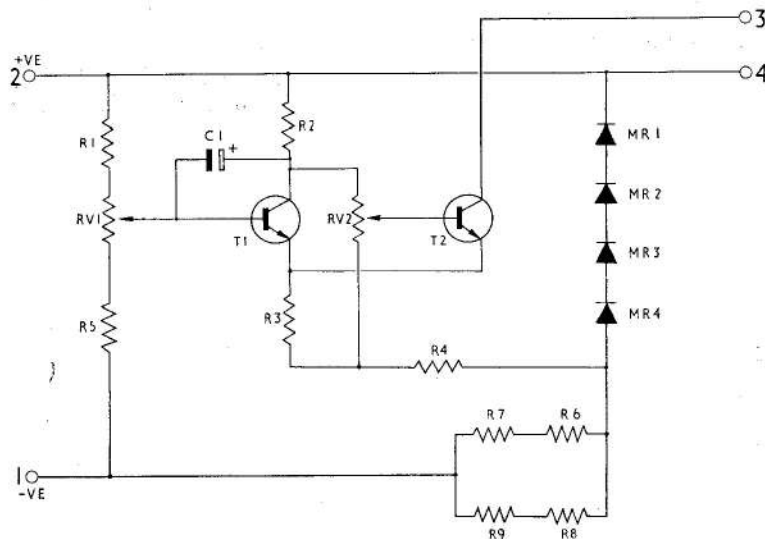

Fig. 4. Circuit diagram

RESTRICTED

Electrical connections

11. Electrical connections are made via four 4 B.A. screw and washer terminations (numbered 1 to 4) in the moulded base. The internal connections are shown in the circuit diagram (fig. 4).

SERVICING

12. Servicing is normally confined to ensuring that the unit is clean and free from damage, all terminal block screws and external nuts and screws should be checked for tightness. The insulation of the connecting leads should be examined for signs of fraying or deterioration and all connections should be checked to ensure that they are secure.

Testing

General

13. All soldered joints should be carefully inspected for dry or high resistance joints.

Continuity tests

14. Terminals 1 and 2 should show approximately 2000 ohms. With the Avometer on the resistance range and the +ve terminal of the Avo connected to terminal 4, there should be an apparent open circuit between terminals 3 and 4.

Insulation resistance test

15. The insulation resistance when measured between the following points should not be less than 0.5 megohm (for R.N.) or 5 megohms (for R.A.F.) when measured with a 250-volt insulation resistance tester.

- (1) Common together terminals 1 and 2.
- (2) Test between commoning lead and metal chassis.

Performance test

16. Connect the units as follows:—

(1) Positive of the supply to terminal 2 of U3606/1.

(2) Negative of the supply to terminal 1 of U3606/1.

(3) Connect voltmeter between terminals 1 and 2 (+ve) of U3606/1.

* (4) Connect milliammeter between terminal 4 (+ve) on U3606/1 and terminal 4 on F7401.

* (5) Connect terminal 3 of U3606/1 to terminal 3 of F7401.

(6) Switch on, and with the supply voltage at a minimum, slowly increase the supply voltage until the current suddenly increases. The pull-in voltage should be 102 volts $\begin{matrix} +3 \\ -2 \end{matrix}$ volts and the load current shall be 60 mA $\begin{matrix} +10 \\ -15 \end{matrix}$ mA.

(7) Slowly reduce the supply voltage until the current suddenly reduces. The supply voltage should be 94 volts ± 2 volts and the load current should be less than 0.5 mA.

Note . . .

(a) The load current, as indicated on the milliammeter, should show a definite switching action and once switched, should show no sign of instability.

(b) All these tests may be carried out without removing the cover.

*Alternatively, a dummy load of 180-ohm 3-watt resistor may be connected via the milliammeter in place of the F7401 relay.

RESTRICTED

Table 1
Circuit component details

Circuit Ref.	Description	Value	Rotax No.
R1	Resistor W/W	470 ohms, 1½ W	N.113590/41
R2	Resistor W/W	270 ohms, 1½ W	N.113590/35
R3	Resistor W/W	47 ohms, 1½ W	N.113590/17
R4	Resistor W/W	56 ohms, 1½ W	N.113590/19
R5	Resistor W/W	4.3 kilo-ohms, 4½ W	N.113592/64
R6	Resistor W/W	820 ohms, 6 W	N.113593/47
R7	Resistor W/W	820 ohms, 6 W	N.113593/47
R8	Resistor W/W	820 ohms, 6 W	N.113593/47
R9	Resistor W/W	820 ohms, 6 W	N.113593/47
RV1	Potentiometer W/W	500 ohms, 1 W	N.145623-214
RV2	Potentiometer W/W	5 kilo-ohms, ½ W	N.67351
T1	Transistor	—	N.151493
T2	Transistor	—	N.151493
C1	Capacitor	12µF 70 V. d.c. Wkg.	N.144000
MR1	Zener diode	—	N.147074/8
MR2	Zener diode	—	N.147074/8
MR3	Zener diode	—	N.147074/2
MR4	Zener diode	—	N.147074/2

RESTRICTED

100

100

100

100

100

This file was downloaded
from the RTFM Library.

Link: www.scottbouch.com/rtfm

Please see site for usage terms,
and more aircraft documents.

