

Chapter 15

CONTROL PANEL, TYPE 15B (ROTAX U1506)

LIST OF CONTENTS

	<i>Para.</i>		<i>Para.</i>
<i>Introduction</i>	1	<i>Voltage control</i>	18
Description	3	<i>Use with Type 24B panel</i>	22
<i>Operation</i>	13	Installation	24
<i>Frequency control</i>	14	Servicing	26

LIST OF ILLUSTRATIONS

	<i>Fig.</i>		<i>Fig.</i>
<i>General view of control panel, Type 15B...</i>	1	<i>Printed circuit</i>	4
<i>Unit with cover removed</i>	2	<i>Circuit diagram</i>	5
<i>Layout of components</i>	3		

LIST OF TABLES

	<i>Table</i>
<i>Control panel components</i>	1

LEADING PARTICULARS

Control panel, Type 15B	<i>Ref. No. 5UC/6539</i>
<i>Voltage output</i>	115V a.c. \pm 2 per cent
<i>Frequency</i>	400 c/s \pm 2 per cent
<i>Temperature range</i>	-50 deg. C to + 100 deg. C.
<i>Overall dimension—</i>	
<i>Length (over feet)</i>	12.186 in.
<i>Width</i>	8.135 in.
<i>Height</i>	5.765 in.
<i>Weight</i>	9 lb. 10 oz.

RESTRICTED

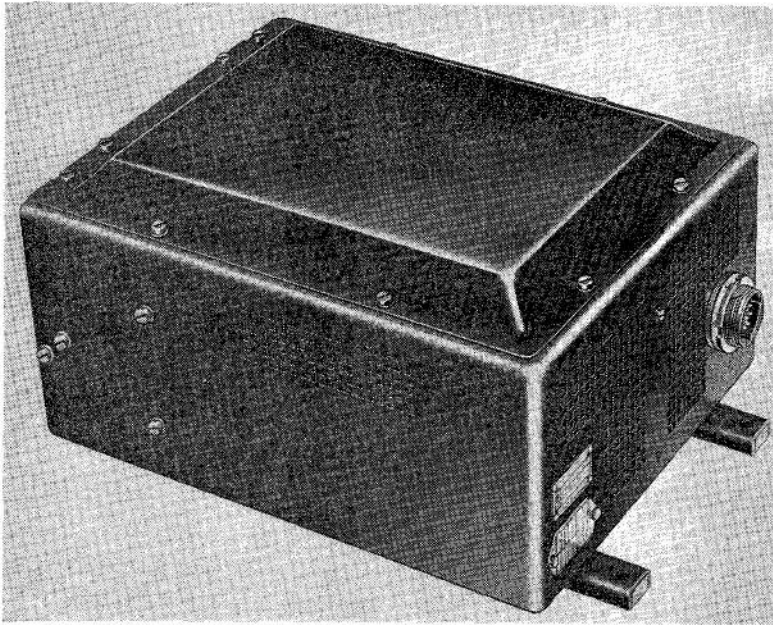

Fig. 1. General view of control panel, Type 15B

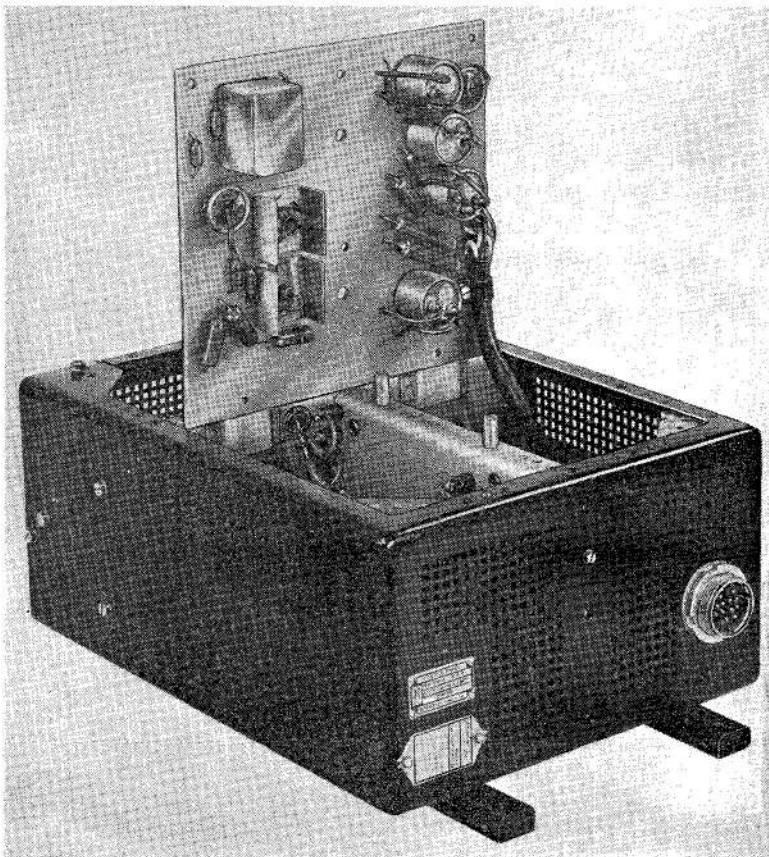

Fig. 2. Unit with cover removed

RESTRICTED

Introduction

1. The control panel, Type 15B (*Rotax U1506*) is designed to control the output of the inverter, Type 103B (*Rotax S3109*). The output of the inverter is controlled at 115-volts, 3-phase, 400 c/s.

2. The maximum load is 770 watts at 0.8 p.f. This load may be increased to 1,500

watts when required by the use of the 24B (*Rotax U2404*) control panel.

DESCRIPTION

3. The control panel, Type 15B (*fig. 1 and 2*) is a completely self-contained unit. It is provided with a 12-pole, high temperature, Mk. 4 miniature plug for connection direct to the Type 103B inverter, or, in some cases,

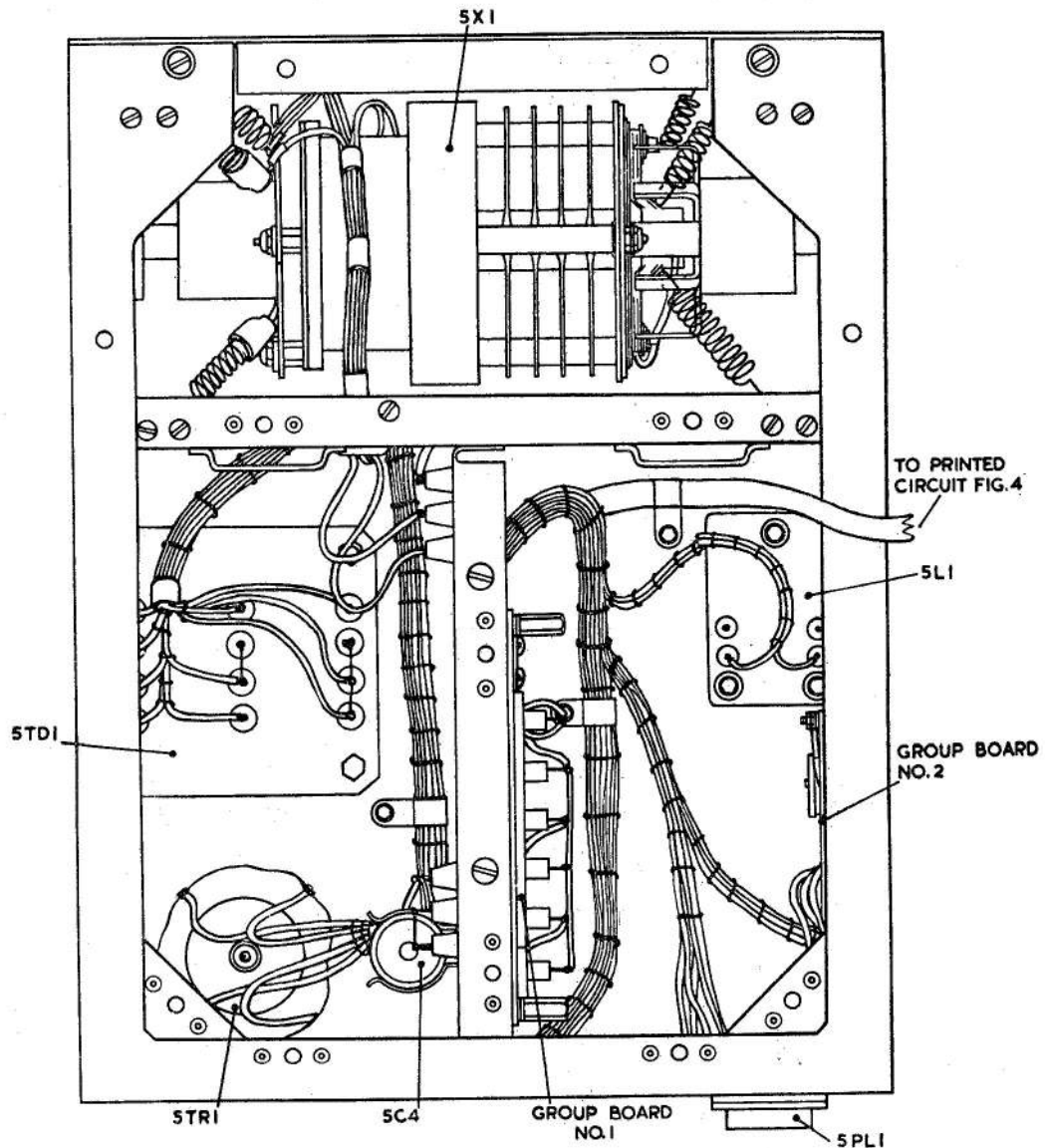

Fig. 3. Layout of components

RESTRICTED

to the Type 24B control panel and thence to the inverter. The plug is fitted to one end of the case and is easily removed for access to the cable form by releasing the external slotted lock-nut, and extracting the plug 5PL1 from inside the case.

4. The unit is in the form of a rectangular metal case perforated at the ends and sides to provide for cooling air circulation. The cover for the unit is formed to permit clearance for the component parts and potentiometer adjustment screws located on the top of the printed circuit panel.

5. Mounted within the case and secured to the base is the toroidal transformer 5TR1, transductor 5TD1, and inductor 5L1 (fig. 3).

6. Supported on each side of the case at one end, is the Newton carbon pile regulator (5X1), held in suspension by eight tension springs, each of which are secured to a removable support plate at one end, and located in two regulator support assemblies at the other end.

7. Integral with the case is the main support partition in the form of a mounting panel; fitted to one side is capacitor 5C4, and on the other side of the panel is a removable glass group board assembly No. 1 incorporating the silicone diodes MR1, MR2, MR3, MR4, MR5, MR6, MR7, MR8, MR10, MR11, MR12, MR13, MR14, MR15 together with resistors 5R9, 5R10 and 5R11.

8. Capacitors 5C2 and 5C3 together with resistors 5R2, 5R7 and 5R8 are located on group board No. 2, which is mounted on the inner face of the outer casing (fig. 3).

9. Two positioning pins are fitted on the top side of the main support partition (para. 7) locating a 0.125 in. thick silicon bonded glass board panel that is copper clad on one side only with copper foil 0.00135 in. thick

10. This constitutes the printed circuit (fig. 4) and is used for inter-connecting the associated component parts assembled on the panel as follows:—Potentiometers 5RV1, 5RV2, 5RV3, and 5RV4, transistor and diode

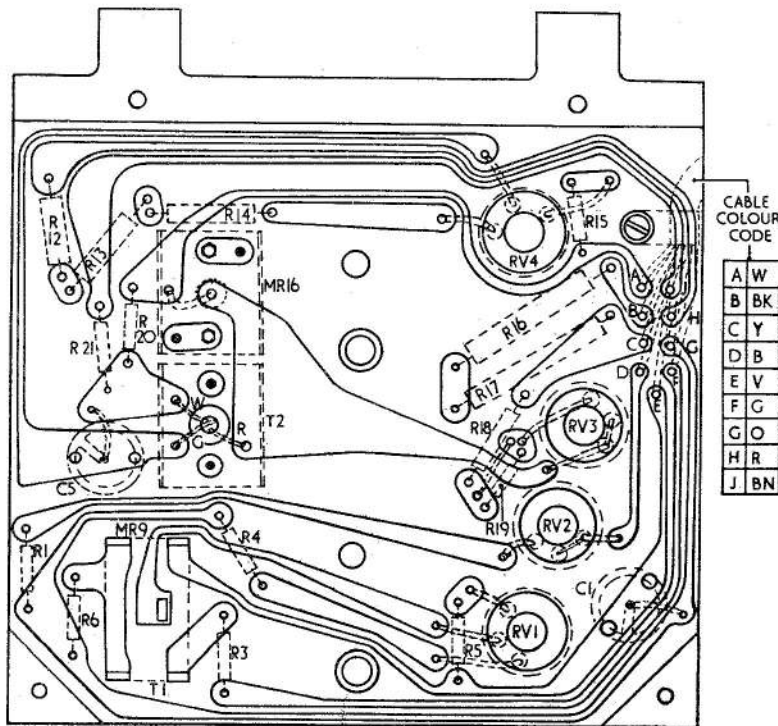

Fig. 4. Printed circuit

RESTRICTED

assembly incorporating transistor 5T1 and reference diode MR9, transistor 5T2, also resistors 5R1, 5R3, 5R4, 5R5, 5R6, 5R12, 5R13, 5R14, 5R15, 5R16, 5R17, 5R18, 5R19, 5R20 and 5R21. Interconnection between these components and the rest of the unit is made by means of the cable shown on fig. 3; the various cores, colour coded as shown on fig. 4 are soldered to nine lettered junction points on the printed circuit panel.

11. If it is found necessary to make adjustment to the potentiometers listed in para. 10, this can be effected by removing the cover and exposing the adjusting screws and locking nuts situated on the panel top of the printed circuit.

12. To gain access to the carbon pile regulator, remove the end plate assembly from one end of the case assembly by first removing the cover; unscrew four cheese-head screws from top and bottom of the case and one screw from each side. The end plate assembly can now be dismantled exposing the carbon pile regulator.

Operation

13. It will be useful to refer to the circuit diagram in fig. 5 of this chapter when reading the following paragraphs, and the system circuitry shown in A.P.4343B, Vol. 1, Book 2, Sect. 7, Chap. 16, App. 1 for further information on the 103B inverter and 24B panel when used in conjunction with the 15B control panel.

Frequency control

14. Frequency control consists of frequency sensitive and transistor driven magnetic amplifier error circuits. The frequency sensitive circuit consists of a saturating transformer 5 TR1 which is supplied from one phase of the 115-volt lines. The output pulses from the transformer are rectified and smoothed, the mean level of the output being proportional to the input frequency from the supply. The mean d.c. is used to supply bias current to magnetic amplifier 5TD1 in the winding C1-C2. The bias level is controlled by means of potentiometer 5RV2.

15. The d.c. is also used to drive the error sensitive circuit of 5T1. A voltage is developed across the potential divider 5R4, 5RV1 and 5R5; the small portion of this voltage developed across 5R5 and the slider of 5RV1 is compared with the constant

voltage developed on zener diode 5MR9. If it is larger the transistor is forced to conduct, if it is smaller the transistor stops conducting.

16. Consider the former. This condition will arise if the frequency rises; the increased output from 5T1 overcomes the bias current and the magnetic amplifier is forced to conduct a high current into the control field of the machine, thus forcing the output frequency down. The converse will be true if the frequency falls below a stipulated value.

17. The magnetic amplifier 5TD1 has a stabilizing winding A1-A2 which is fed from the transducer output via 5R7, 5R8, 5R2, 5C3 and 5C2. Trimming of the output frequency is obtained by adjustment of potentiometer 5RV1 in the potential divider circuit. This alters the base signal applied to the transistor 5T1 thereby modifying the collector current flowing to the transducer.

Voltage control

18. Voltage supplied by the alternator is controlled by the sub-circuits as follows: error detecting amplifier 5T2, 5MR16, potential divider 5R12, 5R13, 5R14, 5R15, carbon pile regulator 5X1 and its ballast resistors 5R16 and 5R17.

19. The three-phase output from the machine is rectified by the silicone diodes 5MR10-5MR15 and the resultant d.c. output of approximately 157 volts is applied across the potential divider 5R12, 5R13, 5R14, 5R15. A portion of this voltage is tapped off at the slider 5RV4 and applied to the base of the transistor 5T2. This voltage is compared with the standing voltage present on zener diode 5MR16; if they are equal no current will flow through the transistor, if it is greater than the standing voltage, a proportionately larger current will flow.

20. The carbon pile is a variable resistance device, the resistance being regulated by isolated control coils. Thus as the current through the control coils is increased, the resistance of the carbon pile increases proportionately to reduce the current in the controlled equipment. The control coils of the carbon pile are split into two windings, one having 1050 turns, the other having 550 turns. The larger is known as the main coil, the other as the auxiliary coil. A standing current is forced to flow via 5MR16, 5RV3, 5R19 and 5R18, through the ballast resistors

RESTRICTED

5R17 and 5R16 to the main coil. This current sets the initial level of carbon pile resistance and hence the level of current which will flow from the 28-volt supply via 4PL1-A, 5PL1-A, 5X1, 5PL1-D, 4PL-D through the alternator field.

21. This level of current will be sufficient to excite the alternator above 115-volts. Immediately it does so the error detecting circuit will conduct a large current through 5T2, 5R21, the auxiliary winding, 5R17 and 5R16 to the main coil. The auxiliary and main coil windings act together to increase the carbon pile resistance and reduce both the field current and alternator voltage. Thus the system stabilizes and the level of output voltage may be adjusted by means of 5RV4. The capacitor 5C5 provides stabilizing feedback. The resistor 5R20 prevents excessive

voltages being generated by the machine should a failure occur to transistor 5T2.

Use with Type 24B panel

22. Under certain conditions of pulsed loading the regulator cannot change its output quickly enough or supply enough excitation current to the machine to enable it to meet the demand. To cater for this a current transformer is interposed between the alternator and the pulsing load. The three alternator outputs are connected to 6PL1-A, 6PL1-B and 6PL1-C, thence to the primary of the transformer and then via 6PL4-1, 6PL4-2, 6PL4-3 to the pulsing loads.

23. Where normal loads are also being supplied these are connected to 6PL2-A, 6PL2-B and 6PL2-C; this current does not flow through the primary of the transformer

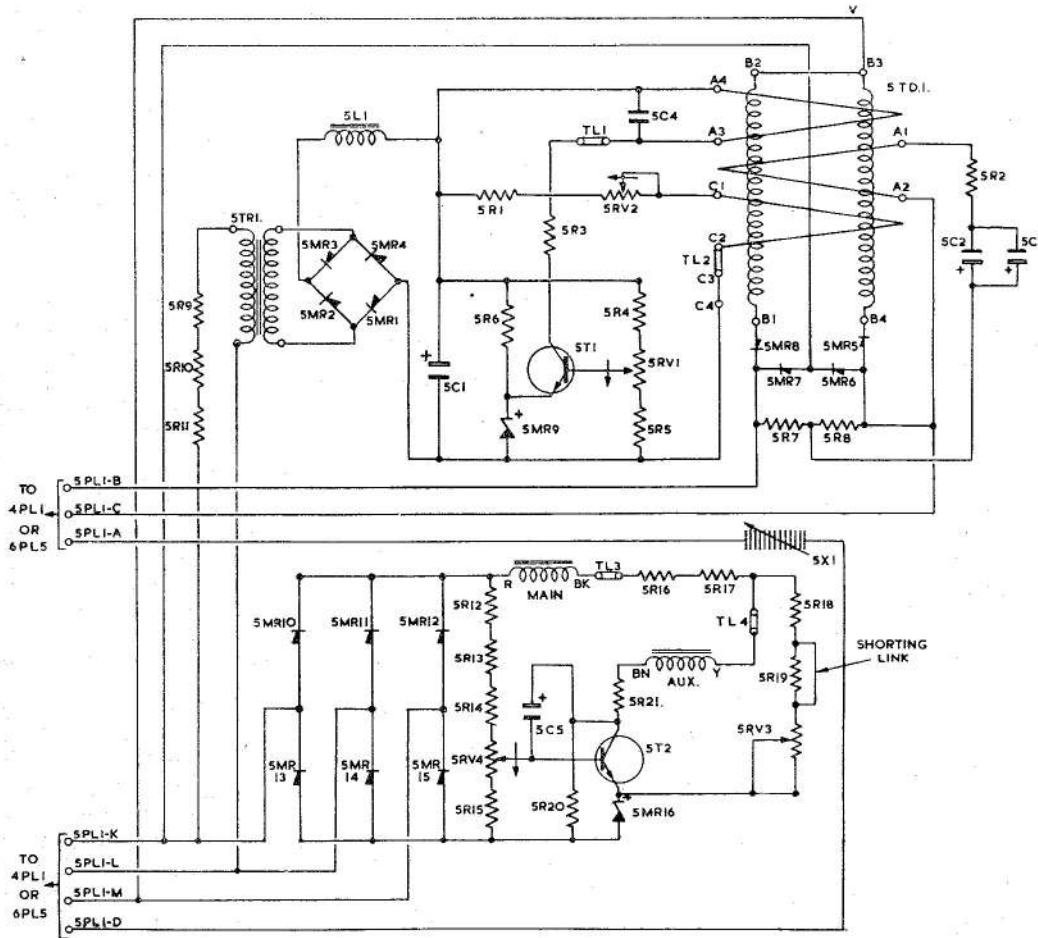

Fig. 5. Circuit diagram

RESTRICTED

6TR1. As pulsed current is drawn through the primary, a large output is generated in the secondary windings. This is full wave rectified in 6MR1 to 6MR6, the d.c. current being passed via 6PL3-D, 4PL1-D to the alternator field, and returned via 4PL1-E, 6PL3E to the rectifiers. Thus a very large pulse of excitation current is generated at the instant that additional load is being offered to the alternator.

INSTALLATION

24. This control panel should be mounted in the vertical plane. Instructions for positioning are given on the front face of the cover: "To be mounted vertically this end uppermost", with the connecting plug projecting from the lower end of the unit. It is recommended that a space of approximately 2.343 in. be provided to allow for withdrawal of the mating socket; this dimension should be taken from the end face securing the mounting plug. It is also important that all ventilating holes are free from obstruction to air flow, and a minimum space of three inches

left at the perforated ends of the unit to allow for adequate ventilation.

25. Four holes $0.265 \begin{matrix} +0.003 \\ -0.0 \end{matrix}$ in. diameter are provided for mounting the unit, and are located in the mounting feet on 11.562 in. and 4.625 in. centres respectively. A 12-pole Plessey high temperature Mk. 4 panel unit plug 2CZ84961 is provided for connecting the unit to the inverter (Type 15B) or the voltage control panel (Type 24B).

SERVICING

26. Servicing of Type 15B control panels will normally be restricted to checking security of connections and that no damage is apparent. Where it is obvious that such components as transformers, rectifiers, etc., are unserviceable, these components will need renewal. Full information will be found in A.P.4343B, Volume 6, Sect. 7, Chap. 15, on testing procedure and fault finding, also insulation resistance testing.

Table 1
Control Panel Components

Components	Description
5R1	Resistor 470 Ω , 1.5W
5R2	" 2200 Ω , 1.5W
5R3	" 200 Ω , 1.5W
5R4	" 390 Ω , 1.5W
5R5	" 270 Ω , 1.5W
5R6	" 330 Ω , 1.5W
5R7	" 470 Ω , 1.5W
5R8	" 1500 Ω , 1.5W
5R9	" 270 Ω , 4.5W
5R10	" 270 Ω , 4.5W
5R11	" 270 Ω , 4.5W
5R12	" 1000 Ω , 3.0W
5R13	" 1000 Ω , 3.0W
5R14	" 820 Ω , 3.0W
5R15	" 100 Ω , 1.5W
5R16	" 240 Ω , 4.5W
5R17	" 270 Ω , 4.5W
5R18	" 270 Ω , 3.0W
5R19	" 150 Ω , 1.5W
5R20	" 4700 Ω , 1.5W
5R21	" 220 Ω , 1.5W

RESTRICTED

Table 1—(continued)

Components		Description	
5RV1	Potentiometer	100 Ω , 1 W	Colvern
5RV2	"	1000 Ω , 1 W	"
5RV3	"	150 Ω , 1 W	"
5RV4	"	50 Ω , 1 W	"
5C1	Capacitor	50 μ F	
5C2	"	50 μ F	
5C3	"	50 μ F	
5C4	"	2 μ F	
5C5	"	50 μ F	
5MR1	Silicon diode	100 mA	Lucas
5MR2	" "	100 mA	"
5MR3	" "	100 mA	"
5MR4	" "	100 mA	"
5MR5	" "	500 mA	"
5MR6	" "	500 mA	"
5MR7	" "	500 mA	"
5MR8	" "	500 mA	"
5MR9	Reference diode	5-75V	B.T.H.
5MR10	Silicon diode	500 mA	"
5MR11	" "	500 mA	"
5MR12	" "	500 mA	"
5MR13	" "	500 mA	"
5MR14	" "	500 mA	"
5MR15	" "	500 mA	"
5MR16	Reference diode	5-75V	"
5TR1	Transformer P10501		Rotax
5L1	Inductor P5501-1		"
5TD1	Transducer P1005-1		"
5T1	Transistor Type 25017		Texas Inst.
5T2	Transistor Type 25017		" "
5X1	Carbon pile regulator Type 37/58306		Newton

RESTRICTED

This file was downloaded
from the RTFM Library.

Link: www.scottbouch.com/rftm

Please see site for usage terms,
and more aircraft documents.

