

Chapter 2

CONTROL PANEL, TYPE 39 (ROTAX U3401/1)

LIST OF CONTENTS

	Para.		Para.
<i>Introduction</i>	1	<i>Frequency regulation</i>	10
Description	2	Installation	15
<i>Voltage regulation</i>	4	Servicing	16

LIST OF TABLES

	Table
<i>List of components</i>	1

LIST OF ILLUSTRATIONS

	Fig.		Fig.
<i>U3401/1 control panel</i>	1	<i>View of right-hand rear of control panel</i> ...	4
<i>View from left-hand rear of control panel</i> ...	2	<i>Theoretical circuit diagram</i>	5
<i>Underside view of control panel</i>	3		

LEADING PARTICULARS

Control panel, Type 39	Ref. No. 5UC/6444
<i>Input voltage</i>	100 to 116 volts d.c.
<i>Output voltage</i>	115 volts \pm 2 per cent 3-phase a.c. (for load range given below) (average of line voltages)
<i>Frequency</i>	400 c/s \pm 2 per cent
<i>Load range</i>	187.5 to 750 watts
<i>Power factor</i>	0.8 lagging to unity
<i>Temperature range</i>	-40 deg. C. to +50 deg. C. (operation may continue down to -55 deg. C.)
<i>Maximum altitude</i>	35,000 ft. (inverter limitation)
<i>Weight</i>	15 lb.

RESTRICTED

Introduction

1. The control panel, Type 39 (Rotax U3401/1), has been designed to control the output voltage and frequency of the rotary inverter, Type 153 (Rotax S3102/1). The input to the system is 100 to 116 volts d.c. and the output is regulated to 115 volts ± 2 per cent 3-phase a.c. (average of line voltages) at a frequency of 400 c/s ± 2 per cent. The performance is maintained with loads between 187.5 watts and 750 watts and a power factor between 0.8 lag and unity.

DESCRIPTION

2. The control panel (*fig. 1*) is a completely self-contained unit provided with a 12-pole plug for connection direct to the associated rotary inverter. The version illustrated in *fig. 2* to 4 is the U3401; the later U3401/1 as described throughout the chapter differs in the addition of a bias circuit and a bias winding to transducer STD3 to achieve optimum voltage regulation. The circuit diagram in *fig. 5* shows the connections for the U3401/1; the list of components in Table 1 and the keys to *fig. 2* indicate which components differ between the two versions.

3. The unit comprises a single deck chassis upon which are mounted various components of the unit. A vertical front-plate is riveted to the chassis. This plate has a voltage trimmer potentiometer, and a frequency trimmer potentiometer mounted behind it,

access to these components being gained from outside through a hole protected by a swing cover plate. A handle is also fitted to the plate. The unit is enclosed by a box cover which is secured by two captive thumb-screws at the rear.

Voltage regulation

4. Excitation of the generator is provided from two sources; the 112 volt d.c. supply through suitable resistors, and the generator's rectified 3-phase a.c. output.

Note . . .

The generator referred to is the a.c. section of the inverter, Type 153.

The latter excitation is governed by the control panel. Should the generator output voltage depart from the required value an error signal is produced in the voltage sensing circuit, amplified, and used to vary the generator excitation to maintain the generator output voltage within specified limits.

5. To obtain sensing to the arithmetical average of the three r.m.s. line voltages, use is made of a positive phase sequence network. The network comprises two circuits forming an open delta, or "V" connection across the generator output lines. Each circuit contains a resistor and capacitor in series. The primary of a step-down transformer is connected between the junction point of resistor and

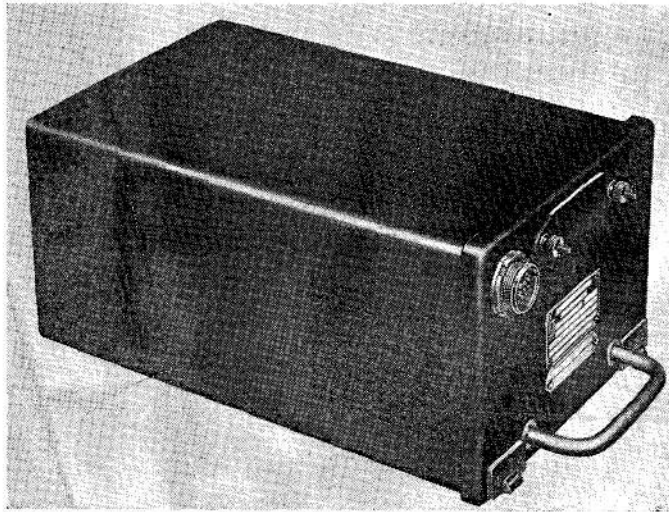
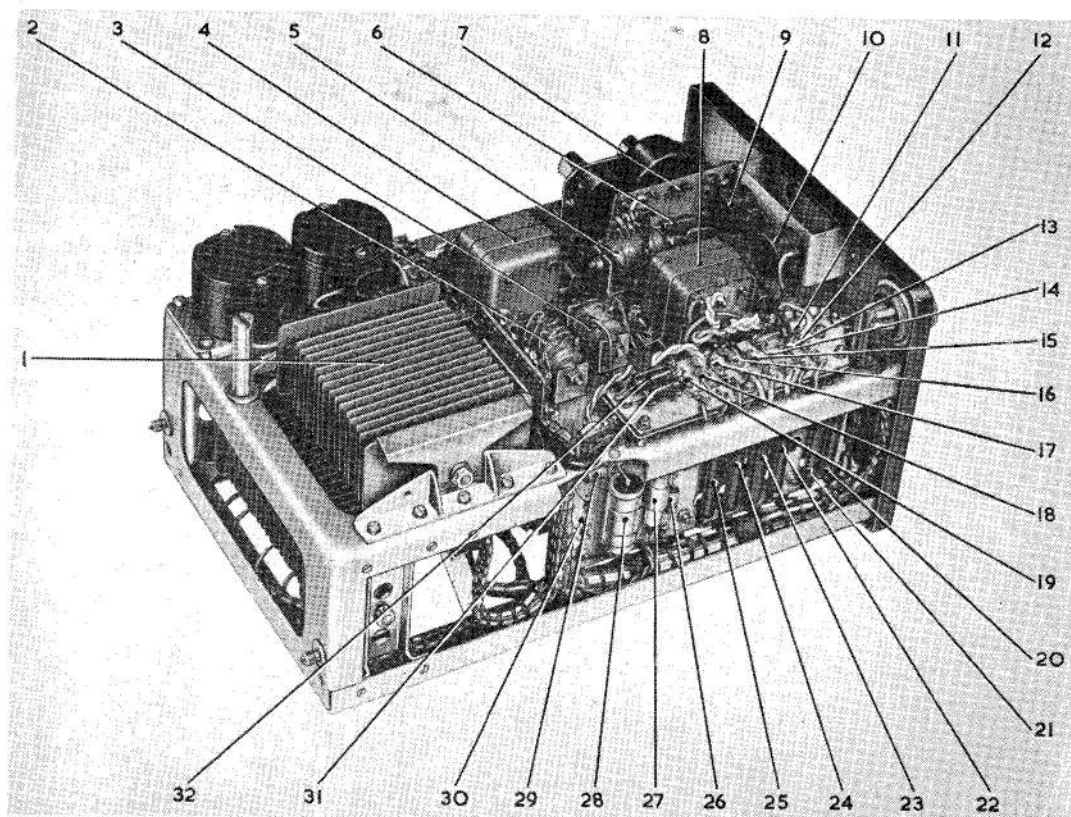

Fig. 1. U3401/1 control panel

RESTRICTED



1	5MR6	12	5TL1	23	5R5
2	5MR5	13	5TL2	24	5R6
3	5MR4	14	5TL3	25	5R7
4	5TR3	15	5TL4	26	5R14
5	5MR1	16	5TL5	27	5C11
6	5R8	17	5TL7	28	5C8
7	5R15	18	5TL8	29	*5R9
8	5TR4	19	*5TL9	30	5TL6
9	5RV3	20	5R2	31	*5R12
10	5RV1	21	5R3	32	*5R13
11	5C3	22	5R4		

* Fitted to U3401 only

Fig. 2. View from left-hand rear of control panel

RESTRICTED

capacitor in one circuit and the corresponding junction in the other circuit. The secondary of the transformer energizes the voltage sensitive circuit.

6. With normal (positive) phase sequence, the component voltage across the transformer primary is proportional to the r.m.s. line voltage for balanced load conditions, and approximately proportional to the average of the three r.m.s. line voltages under conditions of unbalance.

7. The voltage sensing circuit comprises two branches, the first containing resistors, a bridge rectifier, and a control winding of a single-phase transductor; the second contains a barretter, a rectifier and a second control winding of the transductor. The current through the first control winding will be proportional to the average of the generator's three r.m.s. line voltages. The current in the second control winding will not vary to the same extent, for the barretter will tend to maintain a constant reference current. This

reference current will be related to the above r.m.s. value, the operating resistance of the barretter depending upon the filament temperature, and filament heating is proportional to the square of the r.m.s. line voltage.

8. Since the control windings of the transductor are connected in opposition, the magnitude and direction of the resultant magnetizing force will depend upon the difference between the two control currents. The current in the resistor branch circuit is adjusted so that at correct generator output voltage a small differential is produced, sufficient to provide bias for the transductor.

Key to Fig. 3

1	5MR2	6	5C5
2	5MR3	7	5TD2
3	5TR1	8	5TR2
4	5TD1	9	5TD3
5	5B	10	5C6

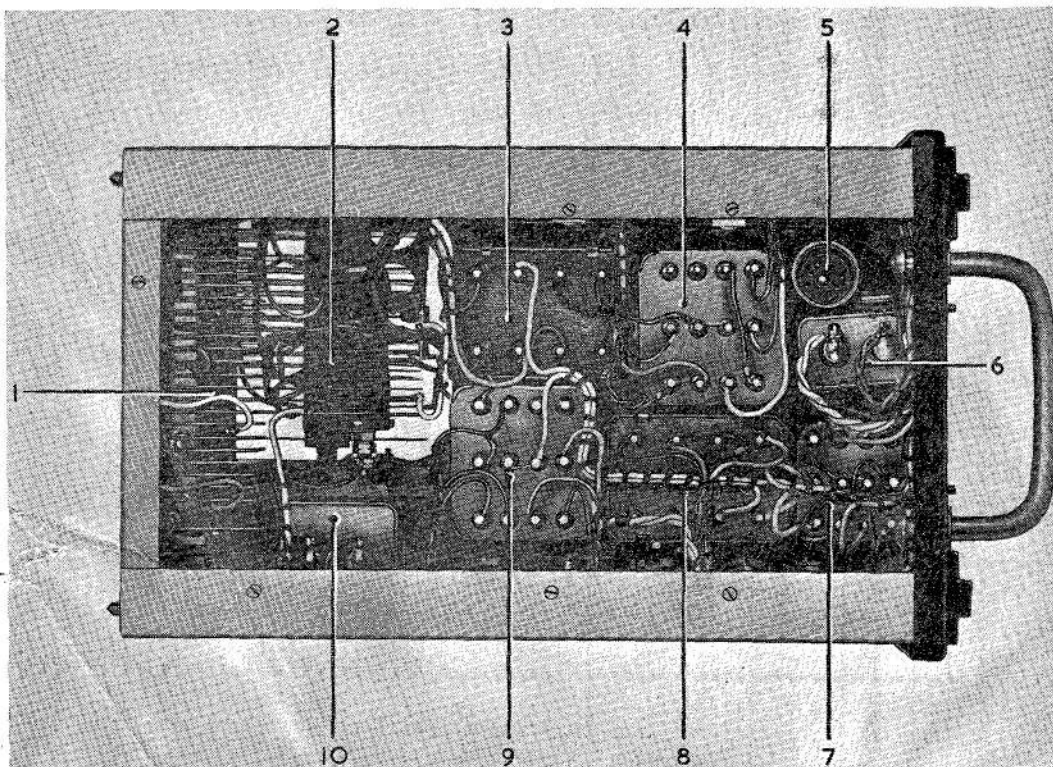

Fig. 3. Underside view of control panel

RESTRICTED

9. A fall in generator output voltage will decrease the differential thereby increasing the core saturation and generator excitation. A rise in generator output voltage will produce the reverse effect. To prevent hunting, the voltage control transducer is provided with a stabilizing winding supplied from the rectified output of the transducer. This feed back is only operative when the output of the transducer is varying.

Frequency regulation

10. Excitation of the motor is provided from three sources:—

(1) By a shunt winding supplied from the 112 volt d.c. supply.

(2) By a series winding carrying the full armature current.

(3) By a control winding supplied from the generators output via the frequency control panel.

Key to Fig. 4

1	5RV2	7	5R11
2	5RV4	8	5C10
3	5L2	9	5C9
4	5L1	10	5C4
5	5C1	11	5R1
6	5C2		

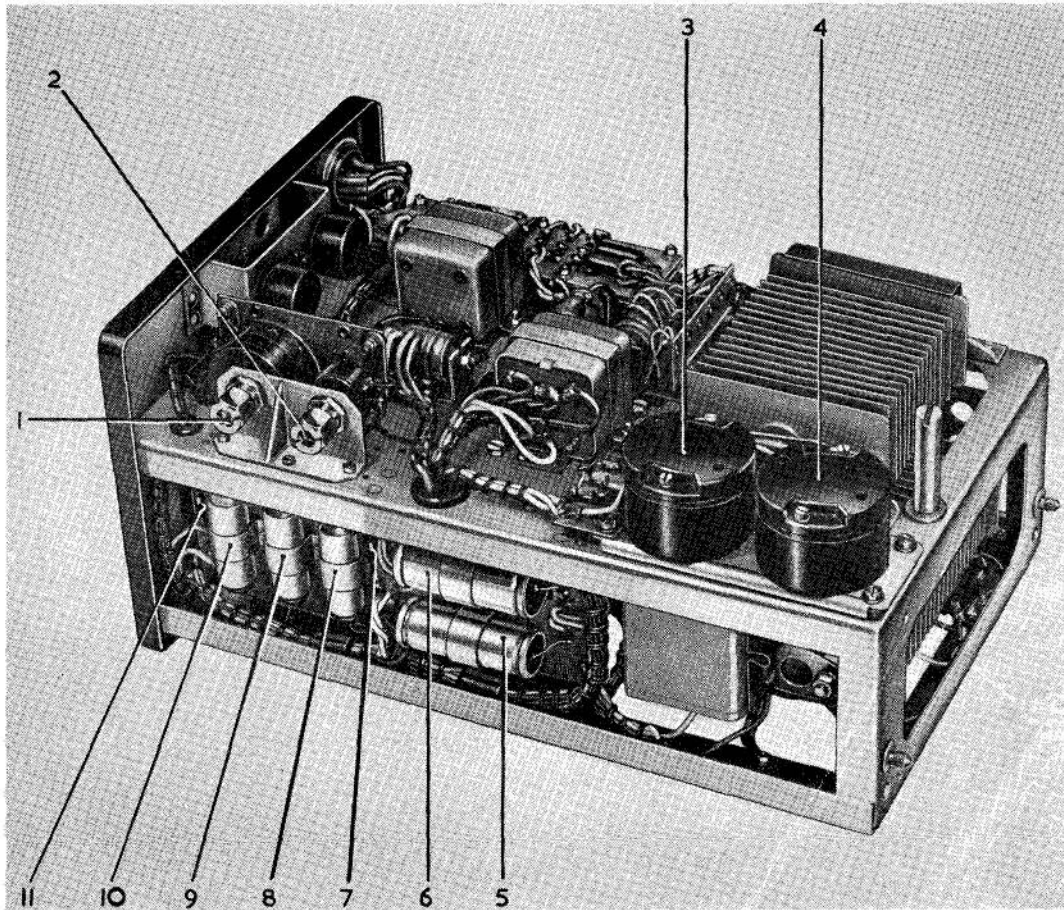

Fig. 4. View of right-hand rear of control panel

RESTRICTED

The control current from the frequency sensing circuit varies the transducer core saturation, and hence varies the impedance of the transducer. This current enables the transducer to govern the speed of the motor, thus keeping the frequency of the generator within the prescribed limits.

11. The frequency sensing circuit comprises two series tuned circuits, the outputs of which are rectified before passing to a control winding on the transducer via a resistive mixing circuit.

12. Each tuned circuit contains a capacitor and a variable inductance. They are supplied from two 10 volt windings on the Scott connected transformers and are tuned to 400 c/s \pm 50 c/s respectively. In consequence their resonance curves cross at approximately 400 c/s.

13. A rise in frequency above 400 c/s causes current in one tuned circuit to rise and that in the other to fall. This differential causes an increase in the transducer output and motor excitation thereby returning the frequency to approximately 400 c/s. In the event of the frequency falling below 400 c/s the reverse effect is produced.

14. To prevent frequency hunting the frequency control transducer is provided with a stabilizing winding supplied from the rectified output of the transducer. This feedback is only operative when the output of the transducer is varying.

INSTALLATION

15. The control panel is designed to be secured to M.O.A. standard tray mounting EL.39463-3B, with flexible mountings. The chassis size is 12 in. in length and 8 in. in width. An air space of at least 2 in. must be allowed, above and below the panel, to provide adequate cooling.

SERVICING

16. Servicing of these units will normally be restricted to checking security of connections and that no damage is apparent.

17. Where it is obvious that such components as transformers, rectifiers, etc. are unserviceable these components will need renewal. A list of components is given in Table 1.

Table 1
List of components

Item	Details
Barretter	
5B	
Capacitors	
5C1	0.39 μ F
5C2	0.56 μ F
5C3	10 μ F
5C4, 5C9, 5C10	40 μ F
5C5	0.9 μ F
5C6	1.6 μ F
†5C7	2 μ F
5C8	1 μ F
5C11	8 μ F
Inductors	
5L1, 5L2	450 mH
Rectifiers	
5MR1-7	(5MR7 on U3401/1 only— not illustrated)
Resistors	
5R1	3.3 K Ω
5R2	130 Ω
5R3	120 Ω
5R4, 5R5, 5R6	110 Ω
5R7, *5R9	100 Ω
5R8	50 Ω
†5R10	100 Ω
5R11	330 Ω
*5R12, *5R13	6.8 Ω
5R14	8 K Ω
5R15	15 Ω
Variable resistors	
5RV1, 5RV2	100 Ω
5RV3	25 Ω
5RV4	750 Ω
Transducers	
5TD1-3	
Transformers	
5TR1-4	
Test links (removable)	
5TL1	Between tags 1 and 2
5TL2	Between tags 3 and 4
5TL3	Between tags 5 and 6
5TL4	Between tags 7 and 8
5TL5	Between tags 9 and 10
5TL6	Between tags 11 and 12
5TL7	Between tags 13 and 14
5TL8	Between tags 15 and 16
*5TL9	Between tags 17 and 18

* Fitted to U3401 only

† Fitted to U3401/1 only—not illustrated.

RESTRICTED

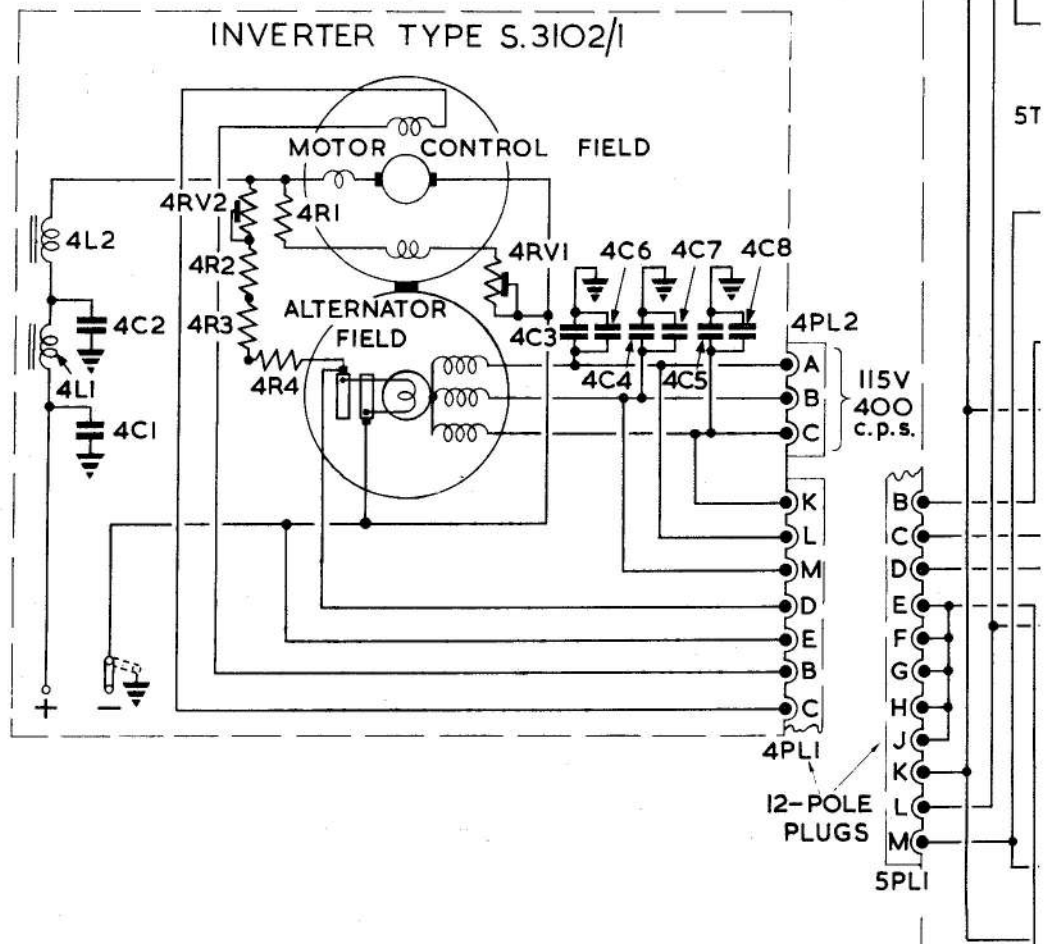

NOTE
 PINS A, F, G, H, & J ON "4 PL1" NOT USED
 PIN A ON "5 PL1" NOT USED

Fig. 5

CONTROL PANEL TYPE

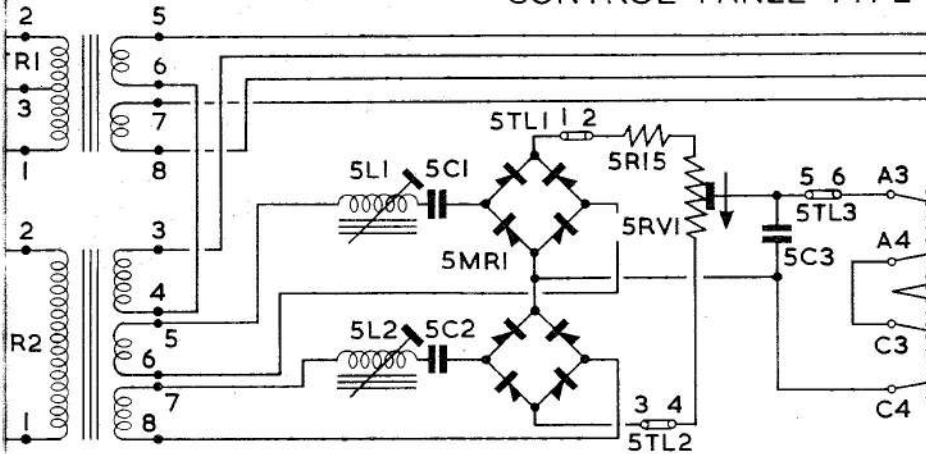

16 15
5TL8

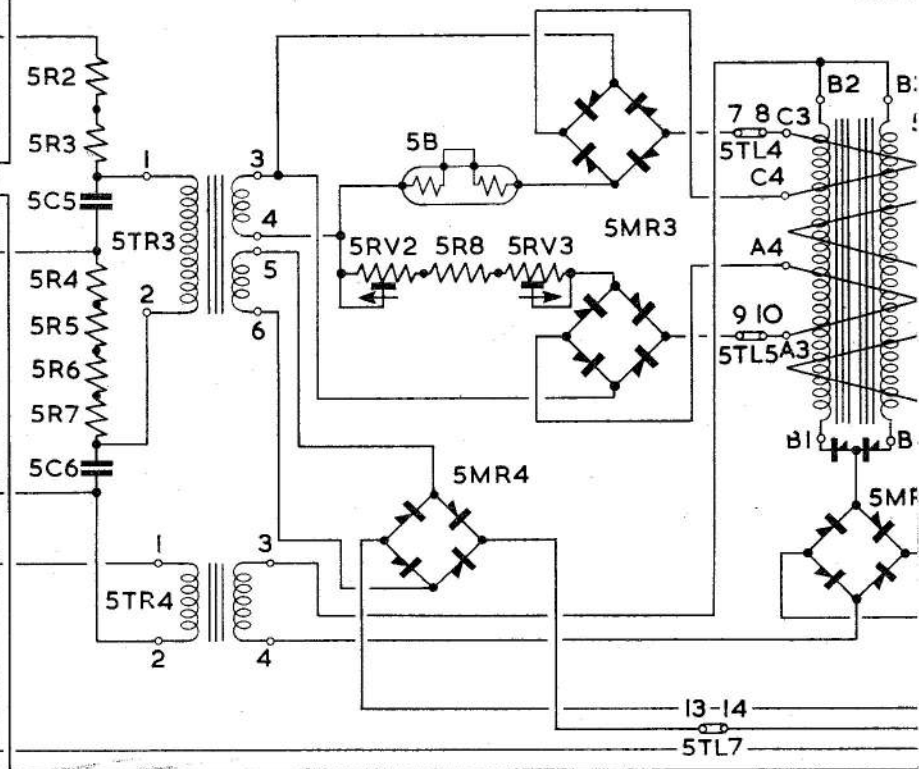

Theoretical circuit diagram
RESTRICTED

L TYPE U.340I/I

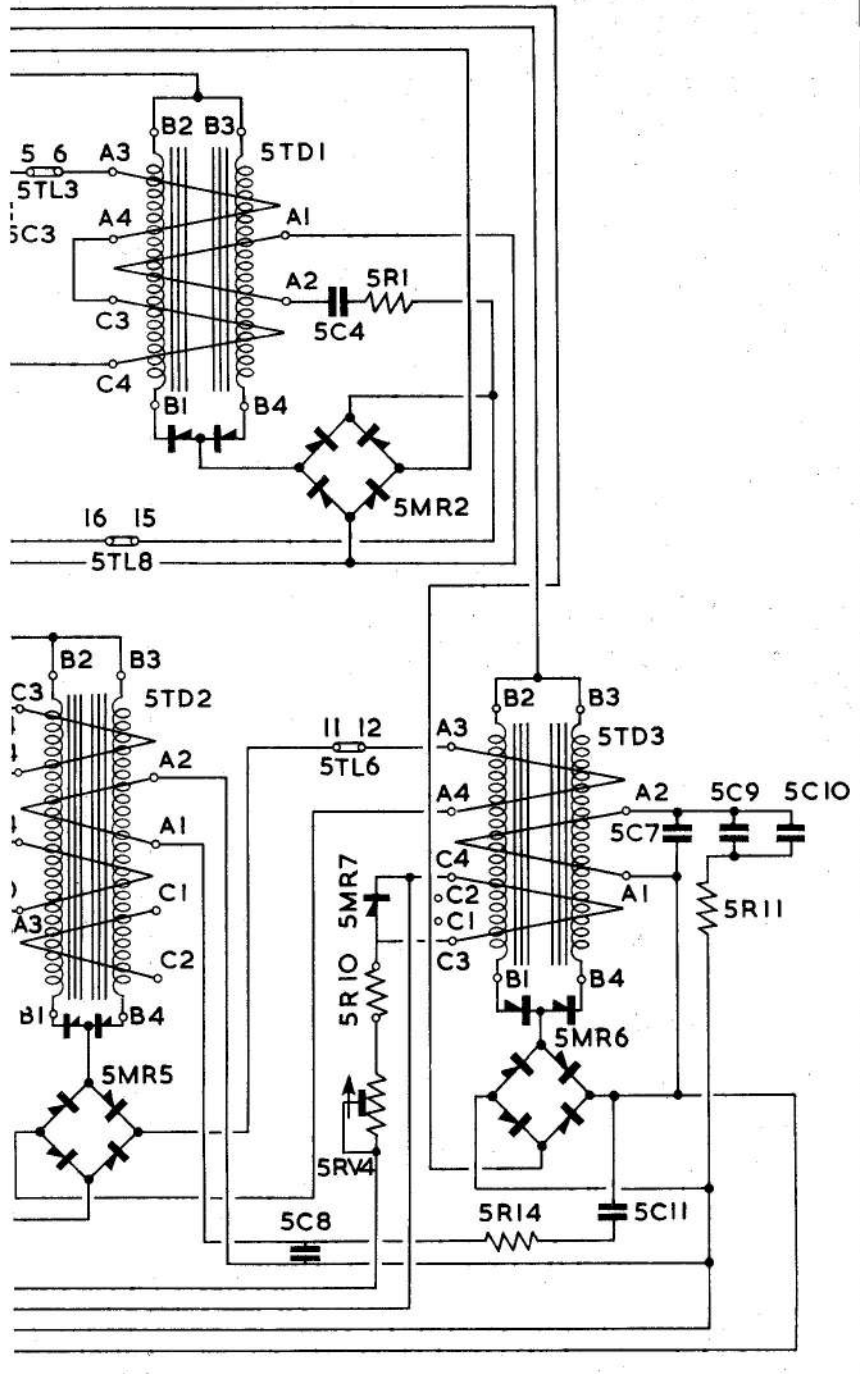

Fig. 5

19

→

→

)

This file was downloaded
from the RTFM Library.

Link: www.scottbouch.com/rtfm

Please see site for usage terms,
and more aircraft documents.

