

**Chapter 4**

**CONTROL PANEL, TYPE 25 (ROTAX U2402)**

**LIST OF CONTENTS**

	<i>Para.</i>		<i>Para.</i>
<i>Introduction</i> ... ..	1	<b>Installation</b> ... ..	4
<b>Description</b> ... ..	2	<b>Servicing</b> ... ..	7
<i>Operation</i> ... ..	3		

**LIST OF ILLUSTRATIONS**

	<i>Fig.</i>		<i>Fig.</i>
<i>Type 25 control panel</i> ... ..	1	<i>Composite circuit diagram</i> ... ..	3
<i>Type 25 control panel, with cover removed</i>	2		

**LEADING PARTICULARS**

<b>Control panel, Type 25</b> ... ..	Ref. No. 5UC/5507
<i>Performance (in conjunction with a Type 153 inverter and a Type 19 control panel)</i>	
<i>Input</i> ... ..	100-V to 116-V d.c.
<i>Output</i> ... ..	115-V $\pm$ 2 per cent. 3-phase a.c. (average of line voltages) 400 c/s $\pm$ 2 per cent.
<i>Operational ceiling</i> ... ..	55,000 ft.
<i>Operational temperature range</i> ... ..	- 55 deg. C to + 50 deg. C.
<i>Length</i> ... ..	6.469 in.
<i>Width (including mounting lugs)</i> ... ..	6.374 in.
<i>Height</i> ... ..	3.200 in.
<i>Weight</i> ... ..	4 lb. 8 oz.

**RESTRICTED**

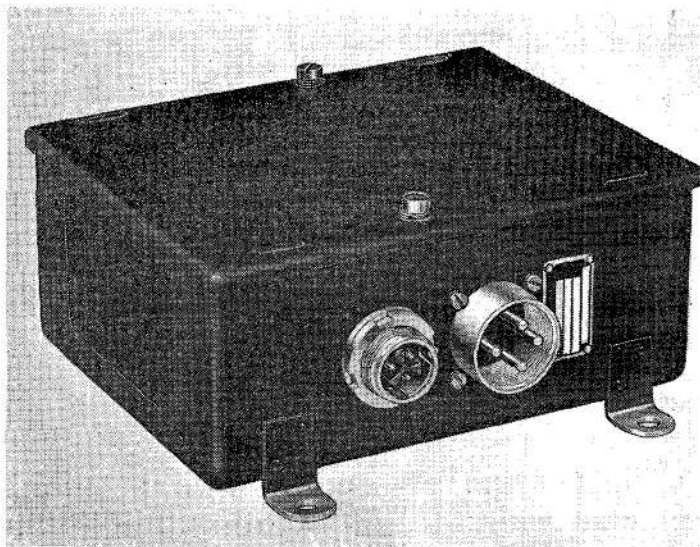

Fig. 1. Type 25 control panel

#### Introduction

1. Type 25 control panel is designed to supplement the Type 19 control panel in regulating the output of the Type 153 inverter in order that, while the rated output is maintained at constant load condition, an additional, pulsating load of 800 watt, unity power factor, duration 400 milliseconds twice per second, may be imposed.

#### DESCRIPTION

2. The panel consists of a three-phase transformer and a rectifier bolted to the interior of an aluminium box. Two opposite sides of the box have gauze windows for ventilation while the remaining sides each carry two plugs (*para.* 6) for external connection. Four mounting lugs are riveted to the sides of the box which is closed by an aluminium cover secured by two screws.

#### Operation

3. Since the Type 19 control panel is not able to respond in sufficient time to the pulses of the additional load, the compounding unit, control panel Type 25, is employed to boost the excitation of the alternator during the load pulses. The primary of the three-phase (compounding) transformer (7 TR 1) within the Type 25 panel is in series with the pulsating load so that an output is obtained

from the two secondary windings only during the pulses. The output from one secondary winding is rectified (7MR 1) and fed directly to the alternator field, thus boosting the excitation during the load pulse. This additional excitation causes an increase in the apparent resistance of the field winding (i.e., as presented to the associated transductor (5 TD 3) of the Type 19 panel) which, uncorrected, would result in a reduction of the transductor output, thereby rendering its control ineffective. The other winding of the compounding transformer, however, is connected in the primary circuit of the output transformer (6 TR 1) in the rectifier unit and thus in the a.c. supply from the transductor (5 TD 3). During the load pulse the transductor supply, and therefore the transformer (6 TR 1) output, is increased and hence the Type 19 panel maintains its contributions to the excitation of the alternator field. By this means the controlled voltage is maintained practically constant during the application of the pulse load.

#### INSTALLATION

4. Four 0.281 in. diameter holes in four lugs riveted to the aluminium box are provided for mounting. Their fixing centres form a rectangle 5.750 in. by 4.500 in.

**RESTRICTED**

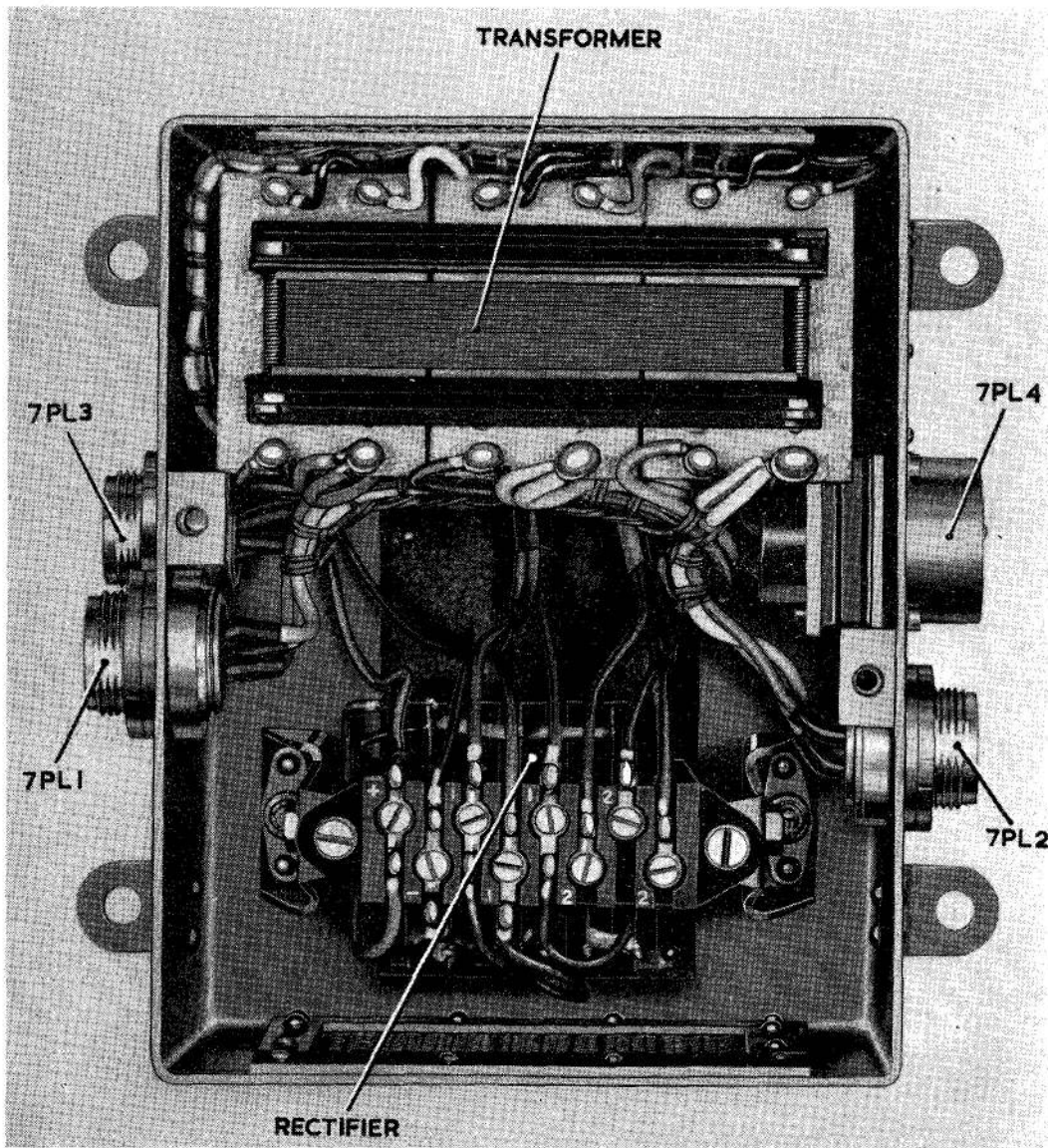

Fig. 2. Type 25 control panel, with cover removed

RESTRICTED

5. The panel must be mounted in a vertical position with the gauze window, through which the transformer is visible, at the top. There must be no obstruction within 1 in. of either window.

6. There are four plugs for external connection, viz:—

7 PL 1 3-pole miniature plug Inter-service Ref. No. Z.560060 requiring mating socket Inter-service Ref.No. Z.560100.

7 PL 2 3-pole miniature plug Inter-service Ref. No. Z.560060 requiring mating socket Inter-service Ref. No. Z.560100.

7 PL 3 6-pole miniature plug Interservice Ref. No. Z.560581 requiring mating socket Inter-service Ref.No. Z.560521.

7 PL 4 4-pole standard plug Ref. No. 5X/6056 requiring mating socket Ref. No. 5X/6059.

#### SERVICING

7. This panel requires no servicing while it is mounted in the aircraft. Trimming adjustments are made at the Type 19 panel and are described in Chapter 3 of this section (*para.* 13).

**RESTRICTED**

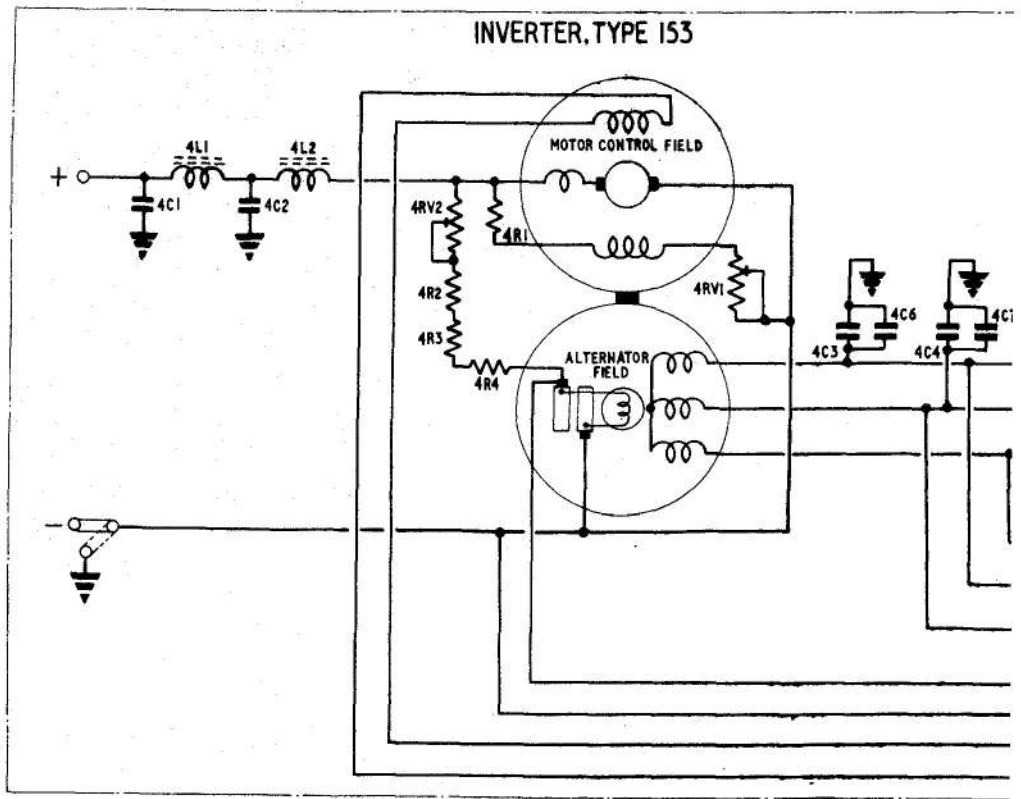
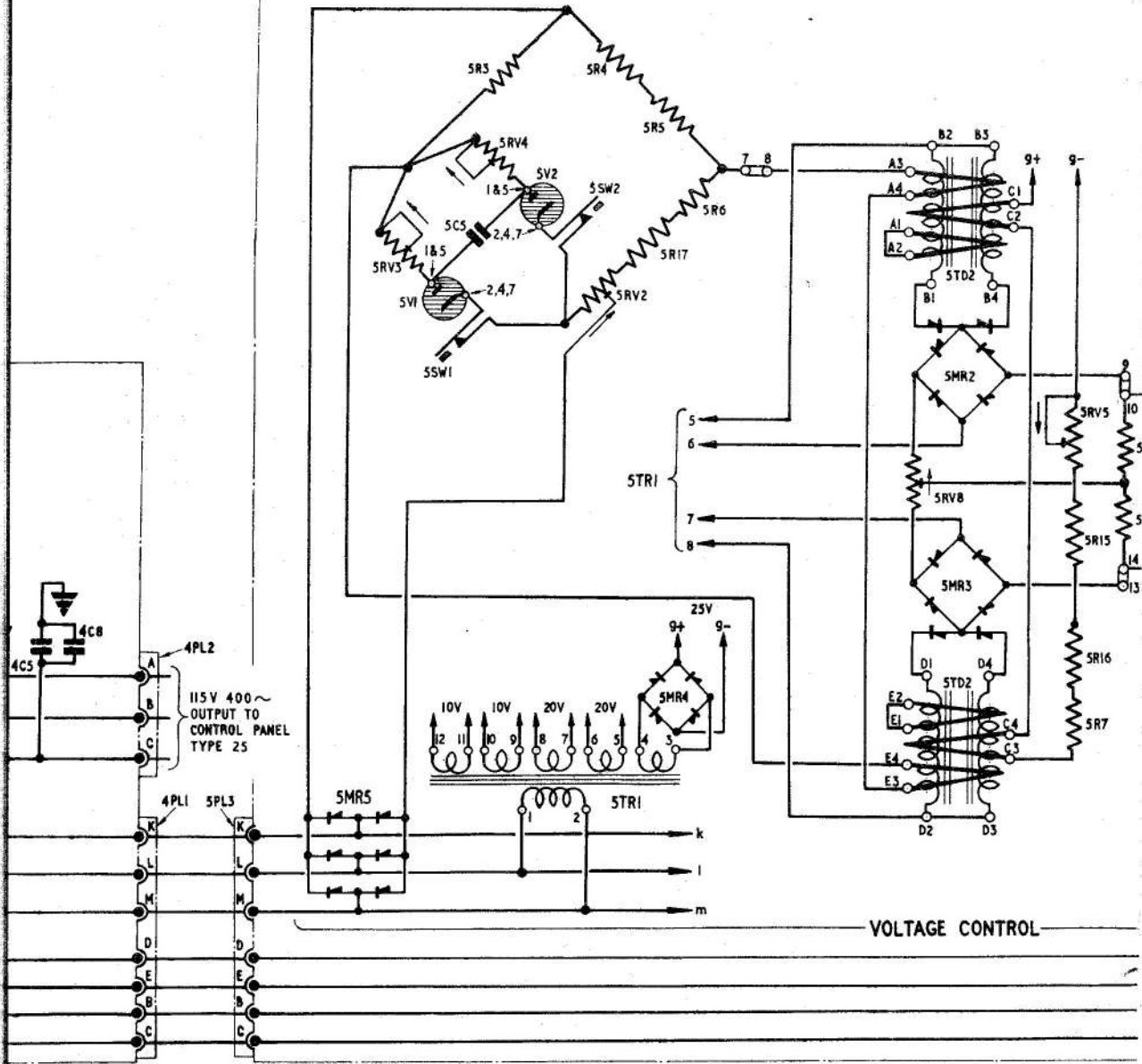
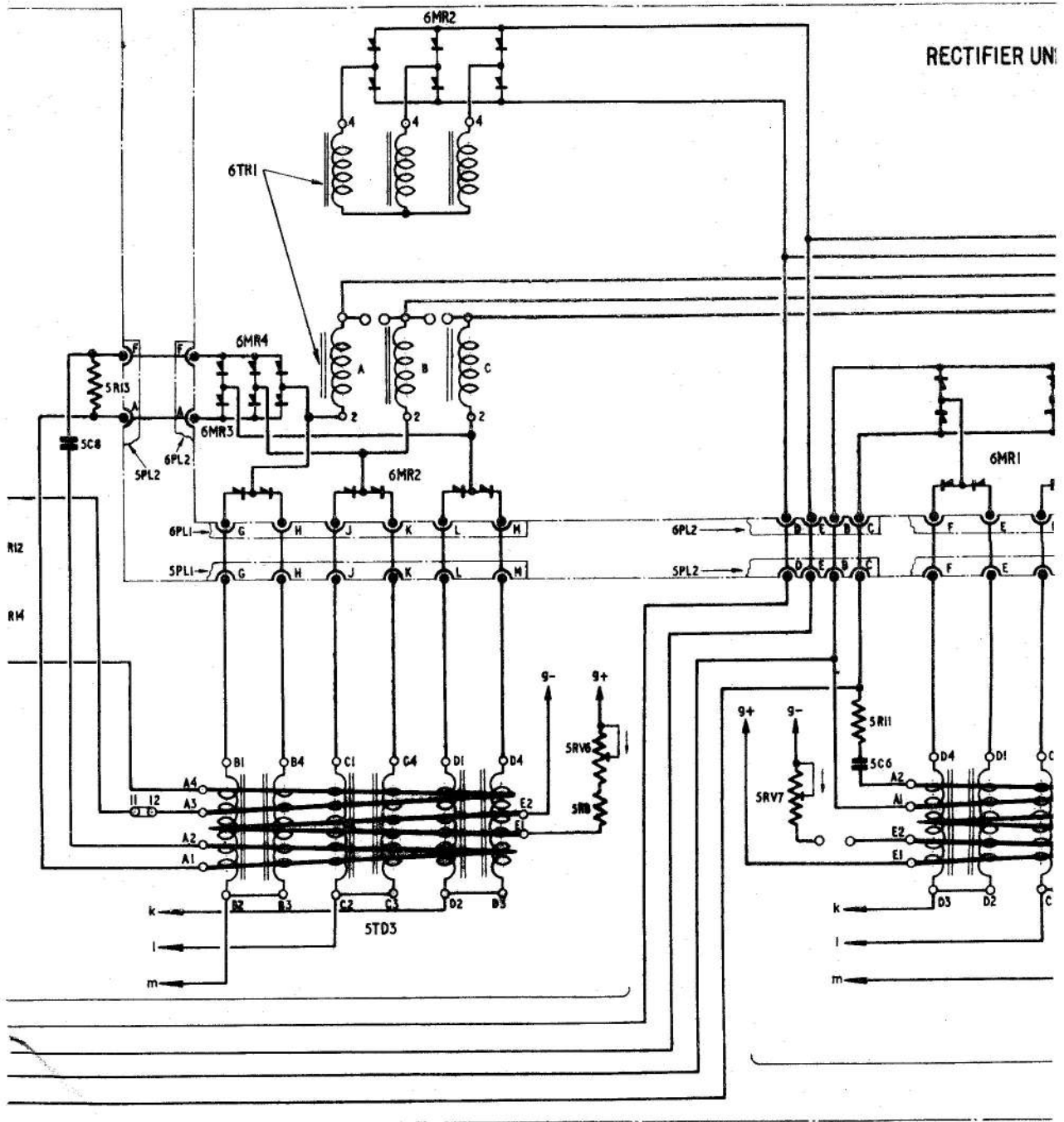

Fig. 3

# CONTROL PANEL, TYPE 19



Composite circuit dia  
RESTRICTE



gram  
D

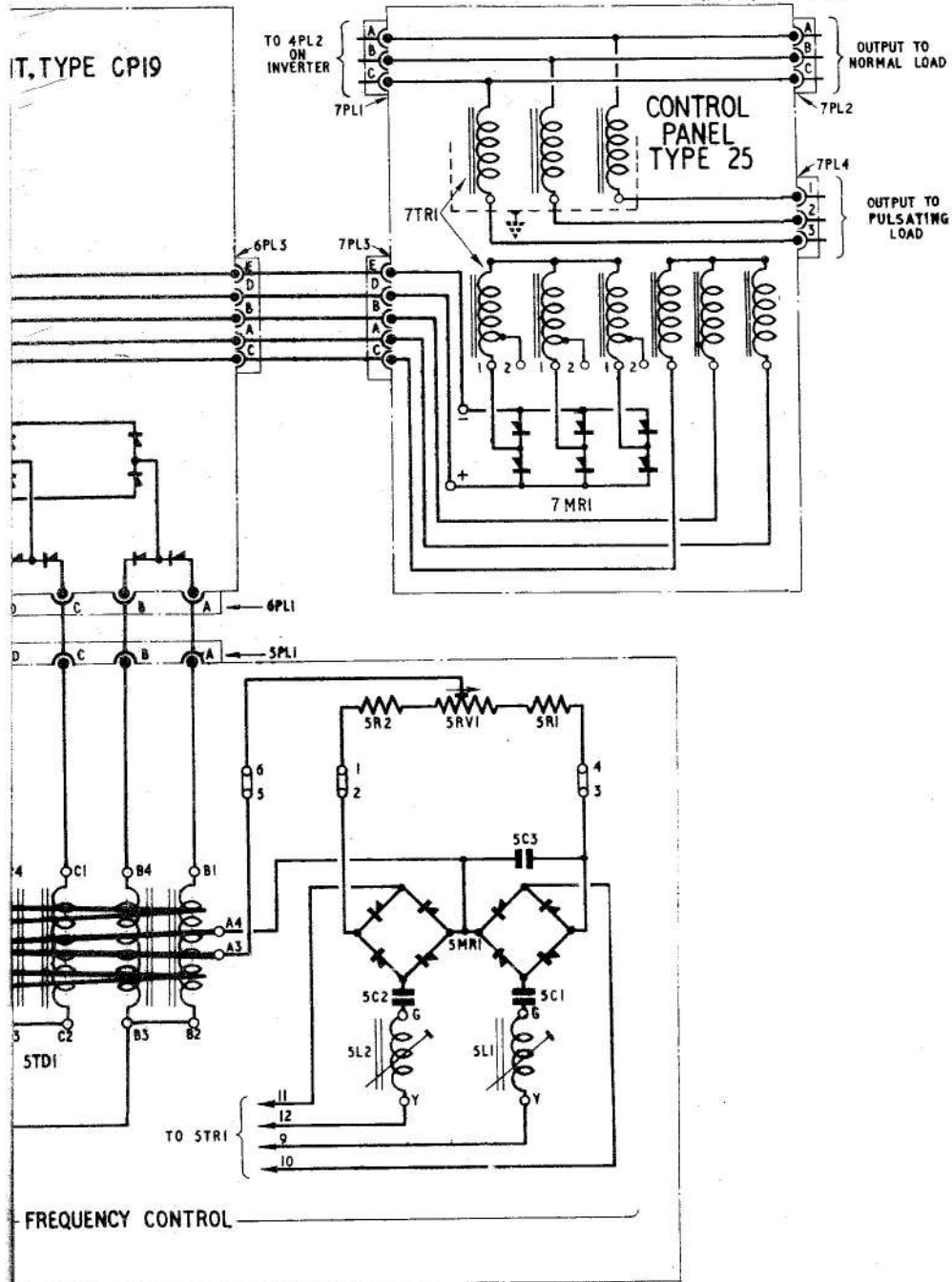

Fig. 3

This file was downloaded  
from the RTFM Library.  
Link: [www.scottbouch.com/rtfm](http://www.scottbouch.com/rtfm)

Please see site for usage terms,  
and more aircraft documents.

