

Chapter 9

CONTROL PANEL, TYPE 9A

LIST OF CONTENTS

	Para.		Para.
Introduction...	1	Installation	9
Description	3	Servicing	10

LIST OF ILLUSTRATIONS

	Fig.
Circuit diagram	1

LEADING PARTICULARS

Control panel, Type 9A	Stores Ref. 5UC/5085
Incorporating—			
Voltage regulator, Type EU2	Stores Ref. 5UC/3886
Magnetic relay switch, Type K3	Stores Ref. 5CW/2472
Switch, Type B	Stores Ref. 5CW/543
Fuse box, Type F	Stores Ref. 5CZ/883
Fuses, Type S	Stores Ref. 5CZ/881
Plugs, Type W198 (4-pole)	Stores Ref. 10H/391
Capacitor, Type 4019 (10 μ F)	Stores Ref. 10C/12582
Capacitor, Type 4188 (4 μ F)	Stores Ref. 10C/12046
Trimmer resistor (50 ohms)	Stores Ref. 5UC/5906

Introduction

1. The control panel, Type 9A, is used for the starting and voltage control of the rotary inverter, Type RC2, which has an a.c. output of 6.25 amp. at 80 volts for an input of 24 volts d.c.

2. The control panel consists of a right-angled metal chassis, with a vertical plate forming the front of the panel, a base plate on which the components are mounted, and a ventilated cover, secured by Dzus fasteners, enclosing the assembly. A list of the principal items is given under Leading Particulars.

DESCRIPTION

3. The single-pole switch, Type B (*fig. 1*), connected in parallel with a remote control switch, is mounted flush with the vertical plate of the control panel. The closing of this switch brings into operation the magnetic relay switch, Type K3; the ON and OFF positions are marked on the front of the switch each side of the dolly.

4. The output voltage is maintained substantially constant by a voltage regulator, Type EU2, of which a full description will be found in Book 1, Sect. 1. In certain early

(A.L.1, Aug. 57)

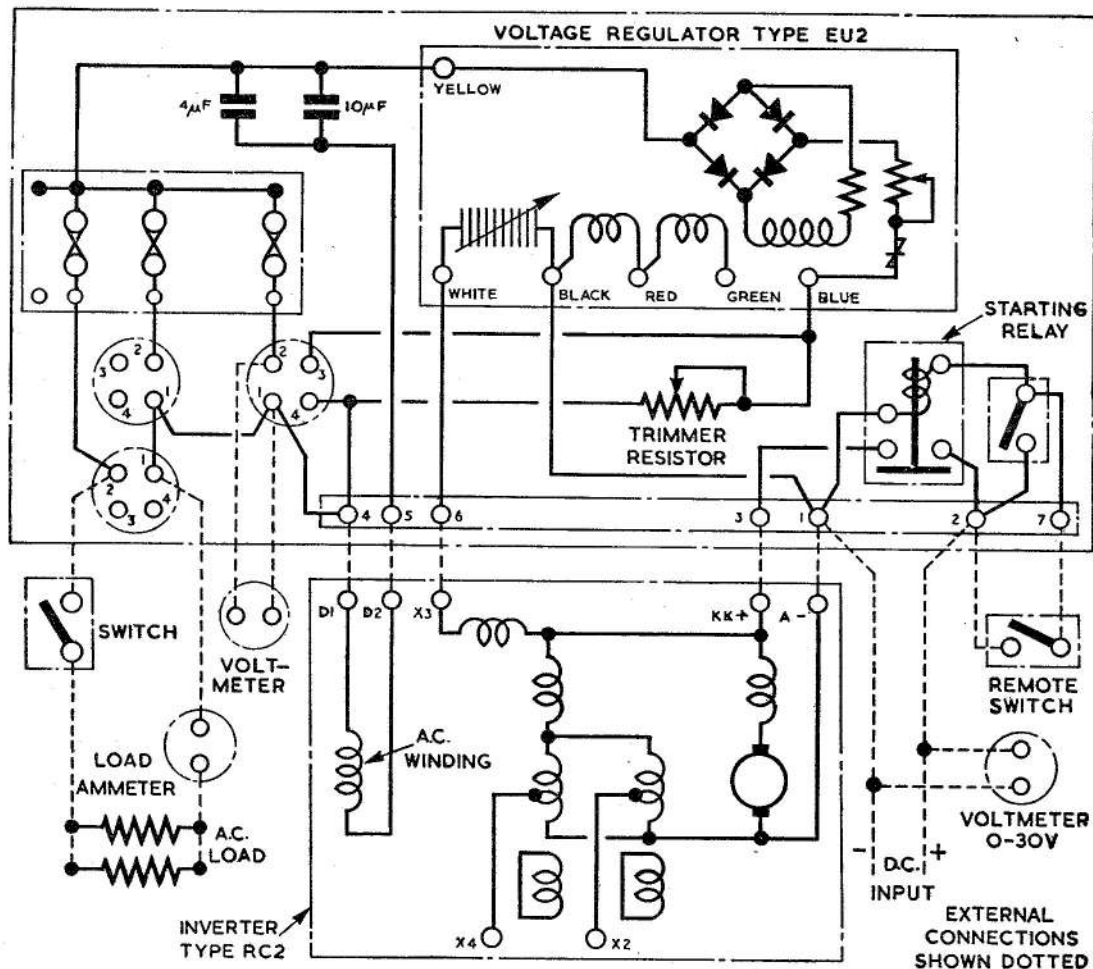

Fig. 1. Circuit diagram

control panels, the regulator will be found to differ from the standard machine in that the stabilizing coil has been removed.

5. Since the trimmer resistor on the regulator itself is not easily accessible when mounted on the control panel, an additional trimmer resistor is mounted behind the front plate of the panel in the top right-hand corner, with an opening in the vertical plate to enable adjustments to be made from the front of the panel. Arrows on the front plate indicate the direction in which the screw must be turned to raise or lower the voltage.

6. Three 10-amp. fuses, Type S, are inserted in the a.c. output leads to the 4-pole W plugs. They are mounted in a fuse box, Type F, which consists of two basic mouldings, a false lid carrying spare fuses, and a protective terminal cover. The fuse box is mounted

directly behind the front plate of the panel, and a detachable cover plate, secured by two winged Dzus fasteners, gives access to the fuse box from the front of the panel.

7. A $10\ \mu\text{F}$ and a $4\ \mu\text{F}$ capacitor, connected in parallel, are inserted in series with the a.c. output; they are mounted next to one another on the base plate of the assembly.

8. Three 4-pole W plugs are mounted on the left-hand side of the front plate; they are connected in parallel, and the a.c. output leads are taken to pins 1 and 2. The terminal block is enclosed in the metal cover at the side of the panel; flanges are provided, through which the cables are taken to their respective terminals.

INSTALLATION

9. The control panel slides into a rack screwed to the airframe. The spring plungers

RESTRICTED

help to maintain efficient earthing and the control panel is held in the rack by two knurled securing nuts bearing on the brass strips screwed to the front of the control panel.

SERVICING

10. The panel must be inspected to ensure the efficiency of all electrical connections and screening arrangements. No servicing can be undertaken on the capacitors; faulty items should be renewed.

11. The movement of the switch, Type B, should be slick and definite; if it becomes slow or sticky, a new switch should be fitted. The magnetic relay switch, Type K3, should need

no attention beyond keeping the switch contacts and the contact plate clean.

12. The voltage regulator should be kept clean and the terminals tight. Minor adjustments to the voltage level may be made by use of the additional trimmer resistor; the movable arm of the trimmer resistor fitted in the regulator is to be left in the mid position. If further adjustment is necessary, it must be done as described in Book 1, Sect. 1.

13. The fuses should be examined and new ones inserted if the element shows signs of sagging or overheating. The blowing of a fuse indicates that the apparatus has developed a fault, which must be investigated and rectified before a new fuse is fitted.



This file was downloaded
from the RTFM Library.

Link: www.scottbouch.com/rtfm

Please see site for usage terms,
and more aircraft documents.



LIGHTNING MK. 1
COVER PITOT HEAD
EB2-88-5111