

Chapter 1

CONTROL PANEL, TYPE 3A

LIST OF CONTENTS

	<i>Para.</i>		<i>Para.</i>
<i>Introduction</i>	1	<i>Installation</i>	6
<i>Description</i>	2	<i>Servicing</i>	7

LIST OF ILLUSTRATIONS

	<i>Fig.</i>
<i>Circuit diagram</i>	1

LEADING PARTICULARS

<i>Control panel, Type 3A</i>	<i>Ref. No. 5UC/2965</i>
<i>Voltage</i>	<i>28V d.c.</i>
<i>Incorporating—</i>	
<i>Voltage regulator, Type EU</i>	<i>Ref. No. 5UC/2544</i>
<i>Suppressor, Type K</i>	<i>Ref. No. 5CY/870</i>
<i>Fuse box, Type N</i>	<i>Ref. No. 5CZ/883</i>
<i>Fuse, Type S (5 amp.)</i>	<i>Ref. No. 5CZ/880</i>
<i>Capacitor, 80 pF</i>	<i>Ref. No. 5UC/1555</i>
<i>Capacitor, Type 423 (0.1 μF)</i>	<i>Ref. No. 10C/9116215</i>
<i>Warning lamp, Rotax, Type H1104 (green)</i>	<i>Ref. No. 5CX/1552</i>
<i>Filament lamp, 24V, 3W, Type A</i>	<i>Ref. No. 5L/9951230</i>
<i>Switchbox, Type B (1-unit)</i>	<i>Ref. No. 5CW/543</i>
<i>Trimmer resistor (100-ohm)</i>	<i>Ref. No. 5UC/3373</i>
<i>Plugs—</i>	
<i>Three Type W198 (4-way)</i>	<i>Ref. No. 10H/391</i>
<i>One Type W199 (6-way)</i>	<i>Ref. No. 10H/392</i>
<i>One Type W204 (2-way)</i>	<i>Ref. No. 10H/397</i>

RESTRICTED

Introduction

1. The control panel, Type 3A, is used to control the voltage output of the a.c. generators, Types R and S, at 80 volts a.c. It incorporates the items of equipment listed under Leading Particulars, and is provided with various inter-connections to a number of plugs on the panel, thus forming a distribution box for both the a.c. and the d.c. supplies to the radio equipment.

DESCRIPTION

2. The components of the control panel are carried on a sheet steel base and front

panel, a sheet steel screening cover sliding over this chassis; effective contact for screening purposes is provided by a number of spring-loaded contact fingers.

3. A circuit diagram is given in fig. 1. The input from the a.c. generator is connected to a 6-pin plug on the panel, and pins 1 and 3, and 2 and 4, of this plug are paralleled to carry the a.c. supply, while the d.c. supply to the generator field is obtained through pins 5 and 6.

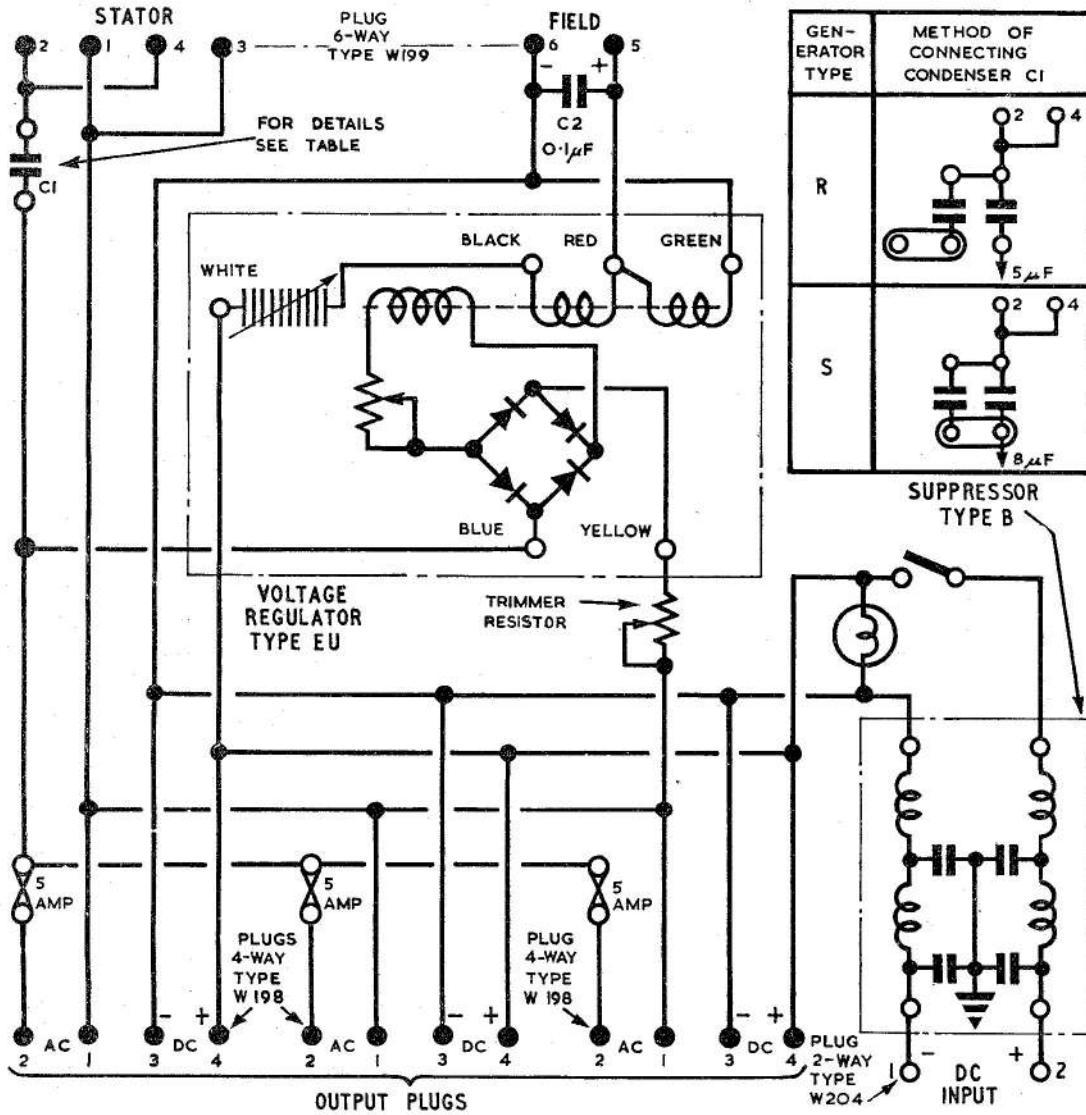

Fig. 1. Circuit diagram

RESTRICTED

4. The a.c. input is fed through capacitor C1, which is fitted to compensate for the high internal reactance of the generator. The capacitor block comprises a $3\mu\text{F}$ and $5\mu\text{F}$ capacitor, with a link arrangement to enable the capacity in circuit to be varied according to the generator employed. The alternative positions of the link are indicated in fig. 1. A $0.1\mu\text{F}$ capacitor C2 is connected across the d.c. field supply, which is fed from the aircraft general services supply through a 2-pin plug and a suppressor, Type B, and through the carbon pile of the voltage regulator, Type EU.

5. The a.c. output is fed through three 5-amp. fuses to pins 1 and 2 of the three 4-pin plugs on the panel, the d.c. supply being connected to pins 3 and 4 of these plugs, which supply the radio equipment. The d.c. supply to the panel is controlled by an on/off switch, and a pilot lamp indicates when the supply is on.

INSTALLATION

6. Care must be taken when installing the control panel to connect the leads in the manner indicated in the circuit diagram. A check should be made that the capacitor unit is correctly connected for the type of generator in use.

SERVICING

7. Servicing of the control panel is normally confined to the voltage regulator, Type EU, which is covered in Book 1, Sect. 1 of this publication.

8. For a test for correct operation of the control panel, it should be connected, by means of the appropriate plugs, to a Type R generator and to a 28-volt d.c. supply. Connect the a.c. pins on the output plugs to a non-inductive load set for 6.25 amp. at 85 volts and to an a.c. voltmeter. The d.c. pins on the output plugs are to be connected to a d.c. voltmeter. The capacitor link must be in the position appropriate to the type of generator used.

Note . . .

The a.c. voltmeter used must be of the rectifier type, free from frequency errors up to 2,500 c/s.

9. With the generator running, check that the a.c. and d.c. output pins are alive and that the generator field is excited when the panel switch is closed and that the d.c. output circuit and the generator field circuit are interrupted when the switch is opened. Each output plug is to be checked in turn.

10. Tests should be made for correct regulation and stability as laid down in Book 1, Sect. 1 for the Type EU regulator.

RESTRICTED

)

)

)

)

This file was downloaded
from the RTFM Library.
Link: www.scottbouch.com/rtfm

Please see site for usage terms,
and more aircraft documents.

