

Chapter 10

CONTROL AND PROTECTION UNIT, ROTAX, TYPE U4901/2

LIST OF CONTENTS

	Para.		Para.
<i>Introduction</i>	1	<i>D.C. section</i>	
Description	2	<i>Rectification and regulation</i>	18
Operation	6	<i>Over-voltage protection and under-voltage warning</i>	19
<i>A.C. section</i>	7	<i>Fault protection</i>	21
<i>Voltage control</i>	9	<i>Load balancing</i>	23
<i>Over-voltage and under-voltage sensing</i>	11	Servicing	24
<i>Merz Price protection</i>	14		
<i>Load and excitation sharing</i>	16		

LIST OF TABLES

	Table
<i>Circuit component details</i>	1

LIST OF ILLUSTRATIONS

	Fig.		Fig.
<i>Control and protection unit, Type U4901/2</i>	1	<i>Inner side of a.c. panel</i>	7
<i>View with d.c. panel in position</i>	2	<i>Outer side of a.c. panel</i>	8
<i>Inner side of d.c. panel</i>	3	<i>View with a.c. panel removed</i>	9
<i>Outer side of d.c. panel</i>	4	<i>Rear view of unit</i>	10
<i>View with d.c. panel removed</i>	5	<i>Plan view of unit</i>	11
<i>View with a.c. panel in position</i>	6	<i>Circuit diagram</i>	12

LEADING PARTICULARS

Control and protection unit, Type U4901/2	<i>Ref. No. 5CZ/6440</i>
Output—	
<i>A.C.</i>	<i>66 kVA, 400 c/s, 200V line</i>
<i>D.C.</i>	<i>3 kW, 28V line</i>
Overall dimensions—	
<i>Length (over mounting lugs)</i>	<i>25.125 in.</i>
<i>Width</i>	<i>12.187 in.</i>
<i>Height</i>	<i>16.250 in.</i>
<i>Weight (estimated)</i>	<i>100 lb.</i>

RESTRICTED

Introduction

1. The control and protection unit, Type U4901/2, is designed to control the output of the 66 kVA a.c. generator, Type 159 (*Rotax BA 1501*). In the Gannet AEW.3 aircraft, there are two of these generators connected in parallel, each with its own control unit. The equipment described in this chapter is to /2 standard, previous modifications causing a change of stroke number from the basic U4901 unit being as follows:—

Type U4901 (*Ref. No. 5CZ/5452*)
Basic design

Mod. Elec. B/468 deleted thermal trip units 1TH1 and 1TH2, which were situated in the lines from terminals 4 and 6 respectively of transformer 1TR2 to rectifier 1MR6. Converted to U4901/1 (*Ref. No. 5CZ/6433*).

Mod. Elec. B/470 changed 1R2 (which was 8.2 ohms, 3 watts) to 18 ohms, 1.5 watts. Converted to U4901/2 (*Ref. No. 5CZ/6440*).

DESCRIPTION

2. The components are housed within a rectangular alloy box provided with four

mounting lugs; four handles on the upper surface enable the unit to be handled easily.

3. Various views of the unit are given in fig. 1 to 11, which show the disposition of the components. Two removable hinged panels, one at each side, carry the majority of the components utilized in the a.c. and d.c. circuits respectively on their inner and outer surfaces; these panels are shown in situ in fig. 2 and 6, and in detail in fig. 3 and 4 (d.c. panel) and fig. 7 and 8 (a.c. panel).

4. A blower is used to circulate cooling air throughout the unit; air is taken in through the gauze inlet at the top of the front end face, and expelled through the outlet beneath it (*fig. 1*).

5. A circuit diagram is given in fig. 12, adjacent to which is a list of components giving such details as Rotax Part Numbers, resistor and capacitor values, fuse ratings, etc. It will be noted in this connection that for convenience, the list prefixes with "1" all items within the unit, with "2" those associated with the a.c. generator, and with "3" those other items in the external circuit; these prefixes appear in the illustrations and

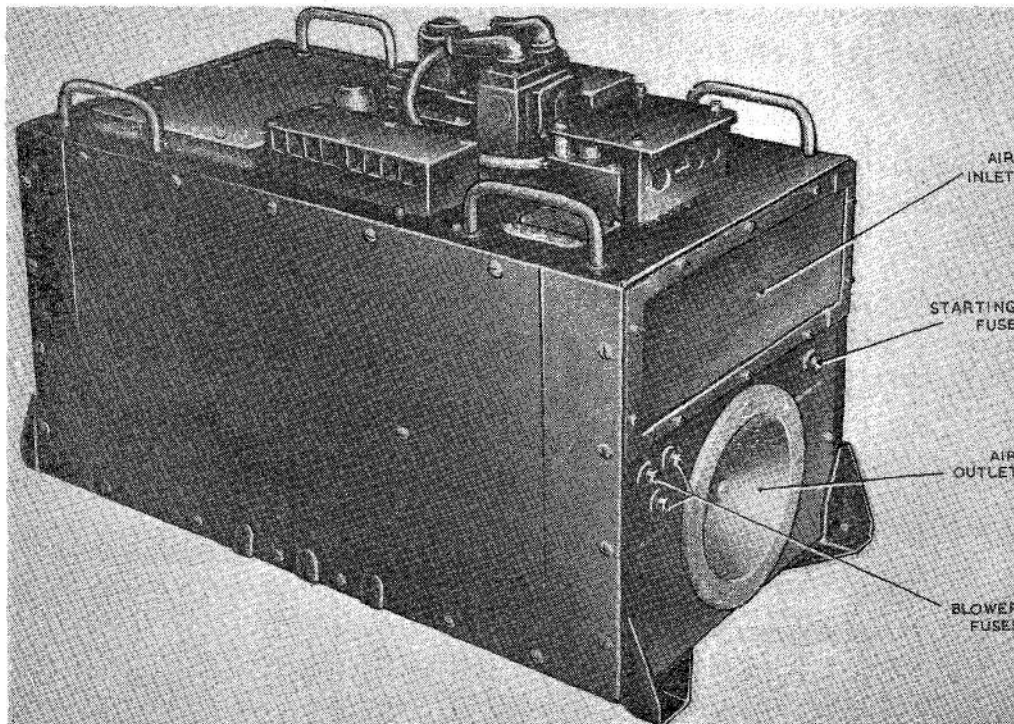

Fig. 1. Control and protection unit, Type U4901/2

RESTRICTED

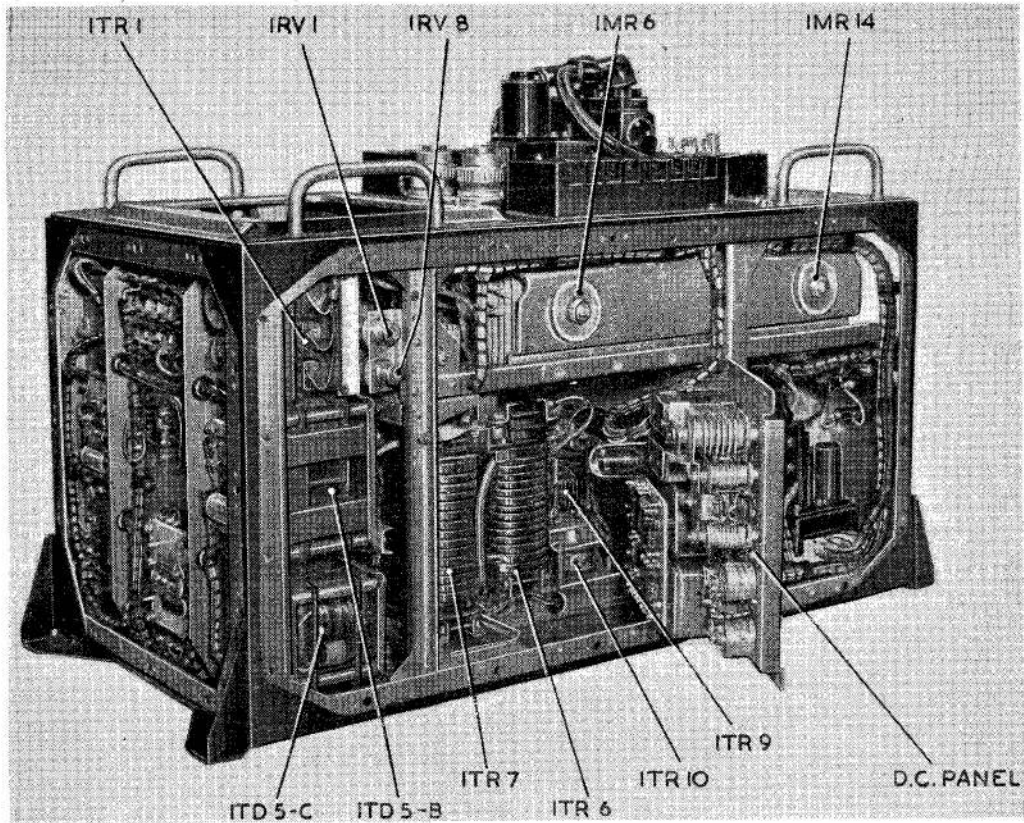

Fig. 2. View with d.c. panel in position

throughout the text, where applicable, but are omitted from the components themselves, which are identified as "MR9", "RV8", etc. on the unit, and also from the circuit diagram.

OPERATION

6. It will be useful to refer to the circuit diagram in fig. 12 when reading the following paragraphs. Further information, including more details of the operation of this equipment in conjunction with the external aircraft circuitry, will be found in the relevant Aircraft Handbook, i.e., A.P.4487C, Vol. 1, Book 2, Sect. 5, Chap. 1.

A.C. section

7. The a.c. generator, Type 159 (*Rotax BA 1501*) provides a supply, the frequency of which is kept constant at 400 c/s due to the constant speed characteristics of the engine. The stator of the a.c. generator is star connected, the star point being earthed after

energizing the Merz Price windings of transformer 2TR1.

8. The d.c. supply to the rotor is provided from the main a.c. output via rectifier 1MR6. A signal, proportional to load current, is supplied from the compounding transformer 3TR2 through the load sharing transformer 1TR10, and a regulation signal from the excitation transductor 1TD1 and excitation transformer 1TR2.

Voltage control

9. The output of the a.c. generator is held at 200V between lines with varying loads by regulating the excitation current; this is achieved by controlling the reactance of the excitation transductor 1TD1. Reactance control is effected by a d.c. winding on 1TD1 which is fed from the pre-amp. rectifier 1MR7; the pre-amp. transductor 1TD2,

RESTRICTED

supplying rectifier 1MR7, is powered from the 3-phase supply transformer 1TR3 and controlled by the signal transformer 1TR5 and rectifier 1MR11, so that its output varies with the generator output voltage.

10. In this manner a change in line voltage alters the output from the pre-amp. transducer 1TD2 applied to the control windings of the excitation transducer 1TD1, so varying the supply, via the excitation transformer 1TR2 and rectifier 1MR6, to the rotor, and thus correcting the original change in line voltage.

Over-voltage and under-voltage sensing

11. Two transducers, 1TD3 and 1TD4, are used for under- and over-voltage protection respectively. These voltage conditions are created by the various faults which may occur. Both transducers are normally quiescent, and an over-voltage will cause transducer 1TD4 to saturate and trip the a.c. protection relay 1RL7, or an under-voltage will cause transducer 1TD3 to saturate and trip the a.c. protection relay 1RL1.

12. A d.c. voltage, proportional to the average of the three line voltages, is obtained via signal transformer 1TR5 and rectifier 1MR11 for under-voltage, and via 3-phase supply transformer 1TR3 and rectifier 1MR1 for over-voltage. These are used to develop error signals in both the pre-amp. stage of regulation and the protection networks. The two control windings on each transducer are of opposite polarity, and at a line voltage of 200V will cancel each other out.

13. One control winding, however, is fed via a resistor chain and will vary with line voltage, while the other control winding is fed via barretter 1L1 and provides a constant bias. The resultant signal produced by these control windings is therefore made to vary in both sense and amplitude as the line voltage varies about 200V. The a.c. protection relays, 1RL1 and 1RL7, are operated by the under-voltage protection transducer 1TD3 and the over-voltage protection transducer 1TD4 at 160V and 245V respectively and are used to trip the main contactor. With both

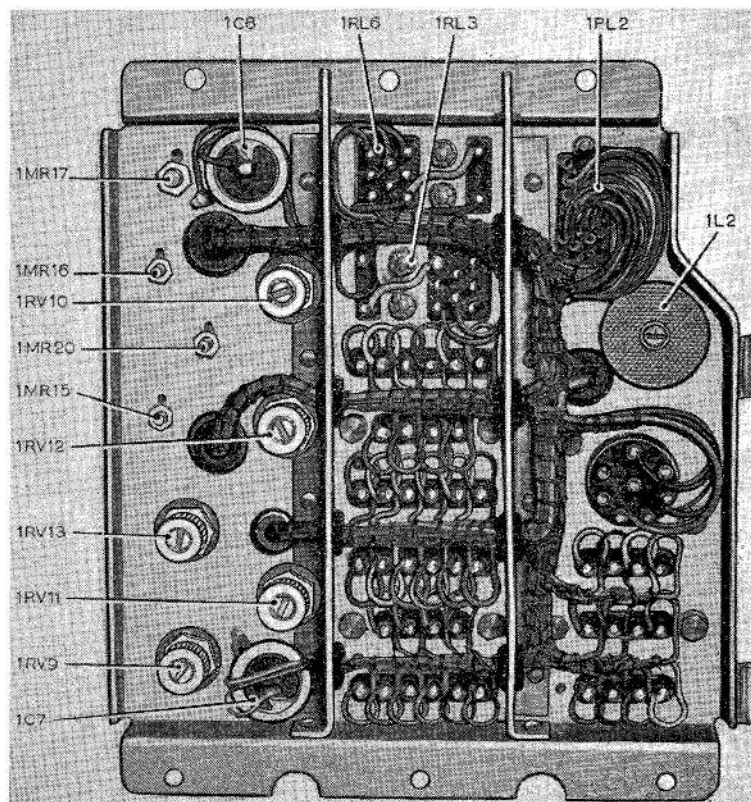

Fig. 3. Inner side of d.c. panel

RESTRICTED

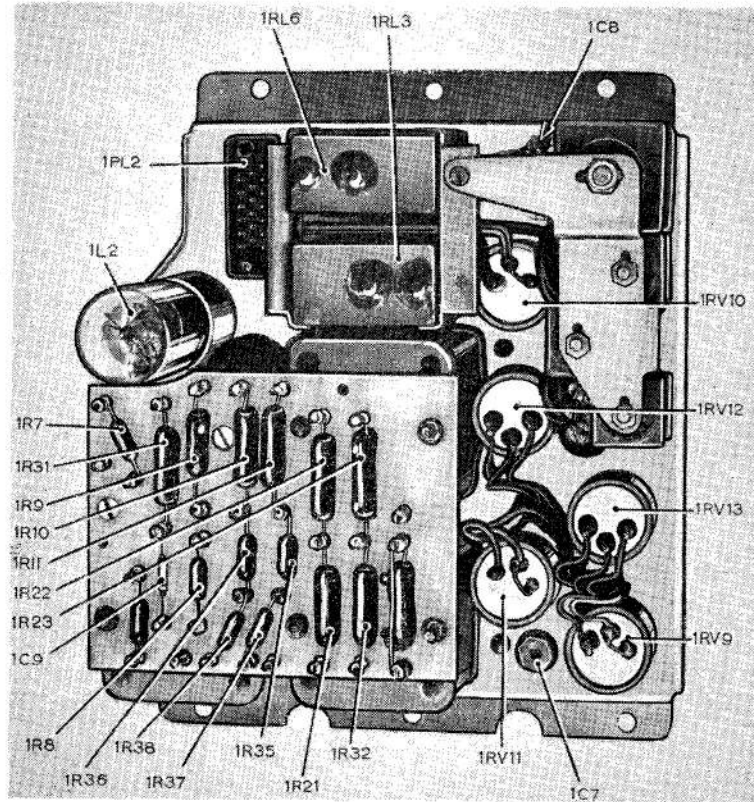

Fig. 4. Outer side of d.c. panel

a.c. generators running on line and sharing the load unequally, the out-of-balance current will flow through 1TD2, 1TD3, and 1TD4 of each control unit, causing:—

(1) On the system with the greater share of the load:—

1TD2 to reduce excitation, line voltage and hence the load taken.

1TD3 to reduce the over-voltage trip level (tripping the system if the load does not equalize).

1TD4 to reduce the under-voltage trip level.

(2) On the system with the lesser share of the load:—

1TD2 to increase excitation, line voltage and hence the load taken.

1TD3 to increase the over-voltage trip level.

1TD4 to increase the under-voltage trip level (tripping the system if the load does not equalize).

Merz Price protection

14. The Merz Price system gives a continuous check on the balance of the currents flowing in the line and neutral connections of each phase of the stator windings, and is responsive to faults either between phases or to earth within the protected zone. The output of the a.c. generator is compared by the current transformer 2TR1 with the input to the bus-bars by the current transformer 3TR1.

15. Under normal working conditions, the outputs from these two transformers will cancel each other out. Under fault conditions, the two outputs will no longer balance, and the resultant signal is rectified by 1MR12 and applied to relay 1RL9, which will trip the main contactor and isolate the unit from the bus-bars.

Load and excitation sharing

16. The load and excitation sensing is achieved by the load sharing transformer

RESTRICTED

1TR10 in the rotor excitation circuit. The secondary output is rectified by 1MR21 and applied to resistor 1R18. The P.D. developed across 1R18 is connected, through the d.c. control windings of the pre-amp. regulating transductor 1TD2 and the protection transductors 1TD3 and 1TD4, to the corresponding circuit in the other control unit.

17. Thus if the load and/or excitation is balanced, there will be no current flow in this circuit since the P.D.'s across the resistors 1R18 in each unit will cancel each other out. Should the loads become unequal, current will flow through both sets of transductors in opposite directions to achieve balanced conditions of load. Under fault conditions, this current flow will oppose the operation of the protection relays of the serviceable channel.

D.C. section

Rectification and regulation

18. The d.c. channel consists of the main transformer 1TR6 and rectifier 1MR14, producing 28V 3 kW d.c. with closed loop regulation and protective circuits. To maintain a constant output voltage, the supply to the rectifier 1MR14 is boosted by a series transformer 1TR7, the amount of boost

being regulated by the boost transductor 1TD5, which is in turn controlled by the pre-amp. transductor 1TD6.

Over-voltage protection and under-voltage warning

19. This protection is provided by two opposing control windings on protection transductors 1TD7 and 1TD8, 1TD7 controlling the under-voltage protection relay 1RL3 and 1TD8 the over-voltage protection relay 1RL6. One pair of d.c. control windings is fed with current which is maintained constant by a barretter lamp 1L2, and the other pair is output voltage sensitive. The resultant signal is arranged to vary in sense and amplitude as the line voltage varies about 28V.

20. At 30V the over-voltage protection transductor 1TD8 becomes saturated, and energizes relay 1RL6, which trips the main contactor. Similarly, with an under-voltage, transductor 1TD7 is saturated at approximately 25V; this de-energizes relay 1RL3 to indicate power failure, but does not in itself trip the main contactor. With both d.c. sections on line and sharing the load unequally, the out-of-balance current will

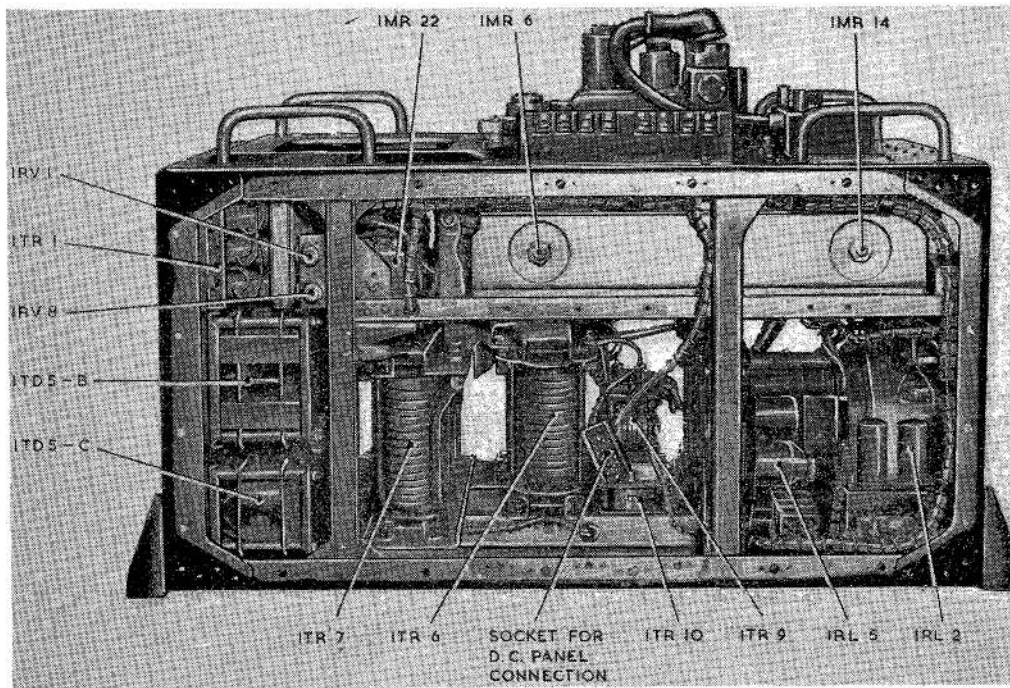

Fig. 5. View with d.c. panel removed

RESTRICTED

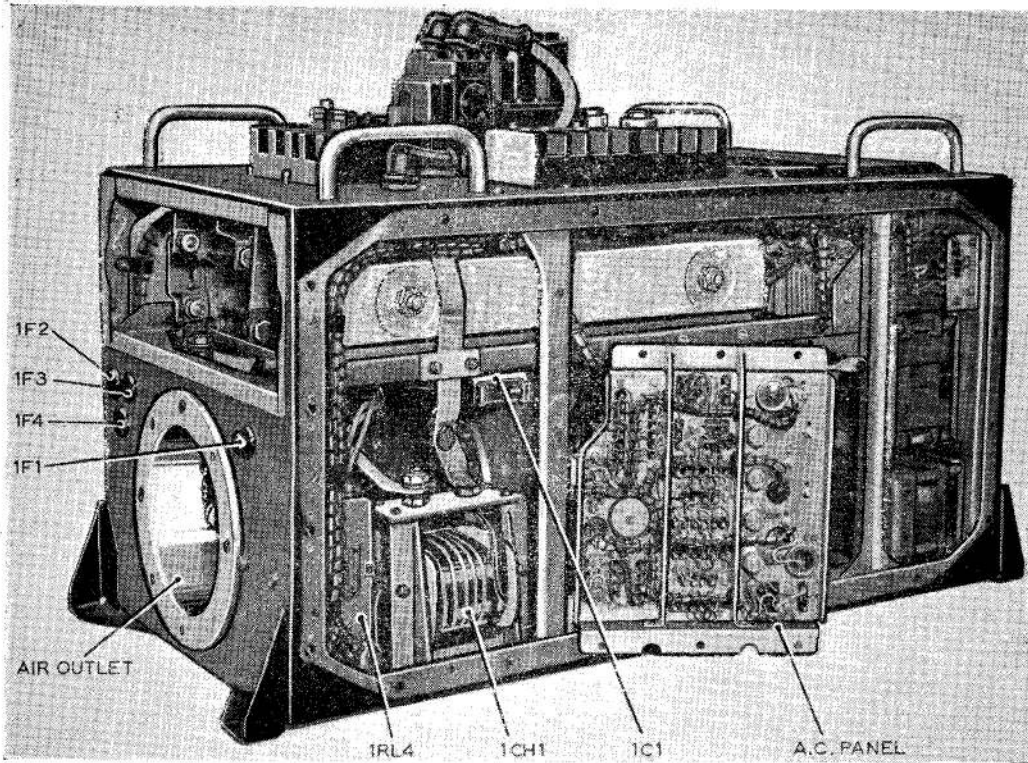

Fig. 6. View with a.c. panel in position

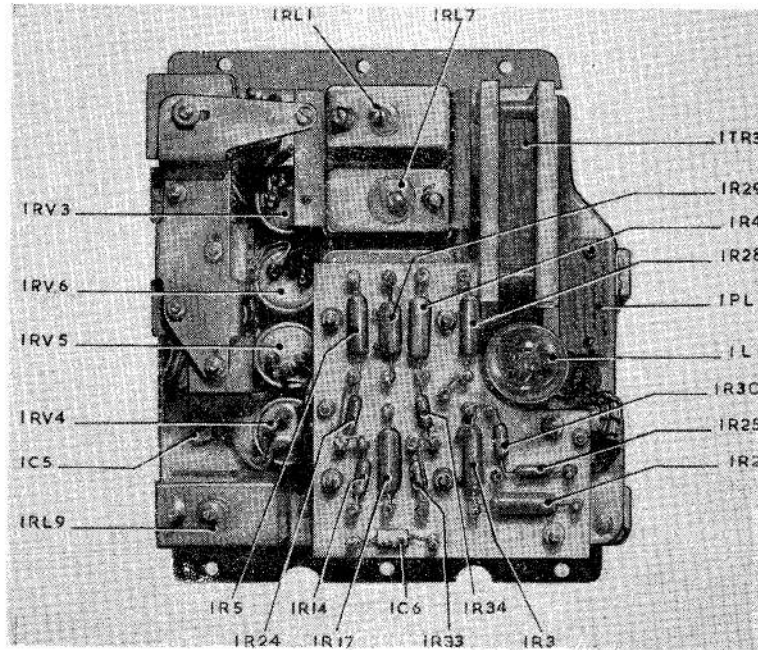

Fig. 7. Inner side of a.c. panel

RESTRICTED

flow through 1TD6, 1TD7, and 1TD8 of each control unit, causing:—

(1) On the system with the greater share of the load:—

1TD6 to reduce line voltage and hence the load taken.

1TD7 to reduce the over-voltage trip level (tripping the system if the load does not equalize).

1TD8 to reduce the under-voltage trip level.

(2) On the system with the lesser share of the load:—

1TD6 to increase the line voltage and hence the load taken.

1TD7 to increase the over-voltage trip level.

1TD8 to increase the under-voltage trip level (giving indication of power failure if the load does not equalize).

Fault protection

21. Two signals, one developed across the series resistor 1R12 and proportional to d.c. output current, and the other via the current sensing transformer 1TR9 and rectifier unit 1MR17, and proportional to input current, are applied to two control windings on the under-voltage protection transducer 1TD7 and the over-voltage protection transducer 1TD8.

22. When a fault occurs on the lines or in the control unit, or there is a d.c. reverse current, the over-voltage transducer 1TD8 will saturate and trip the d.c. channel from the line. Alternatively, should the fault be under voltage, the under-voltage transducer 1TD7 will saturate and will indicate power failure by energizing the d.c. failure magnetic indicators and power failure warning lamp.

Load balancing

23. Load balancing is achieved by comparing the input current signal, obtained

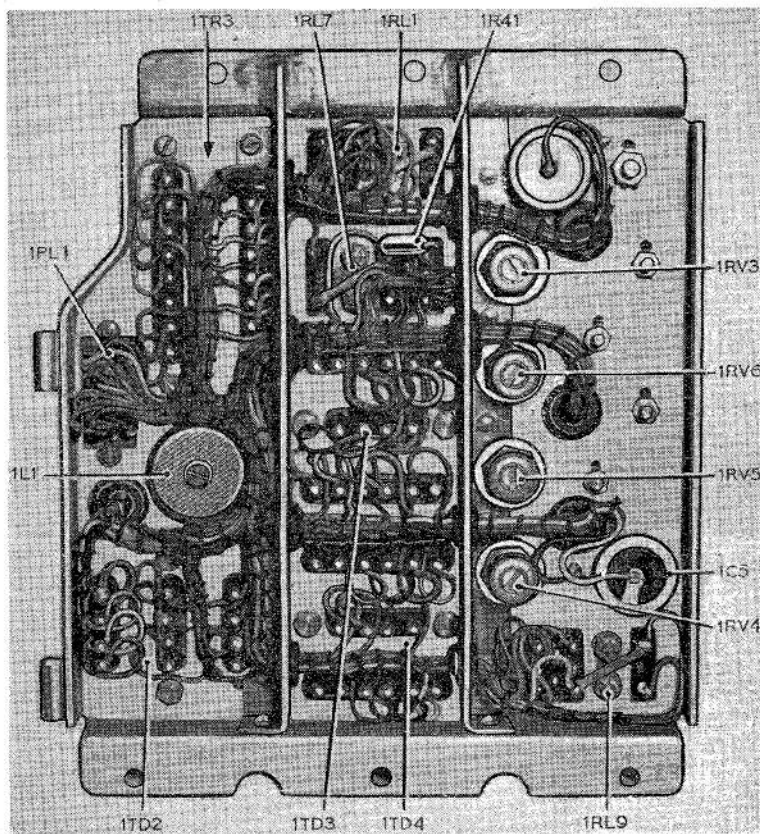

Fig. 8. Outer side of a.c. panel

RESTRICTED

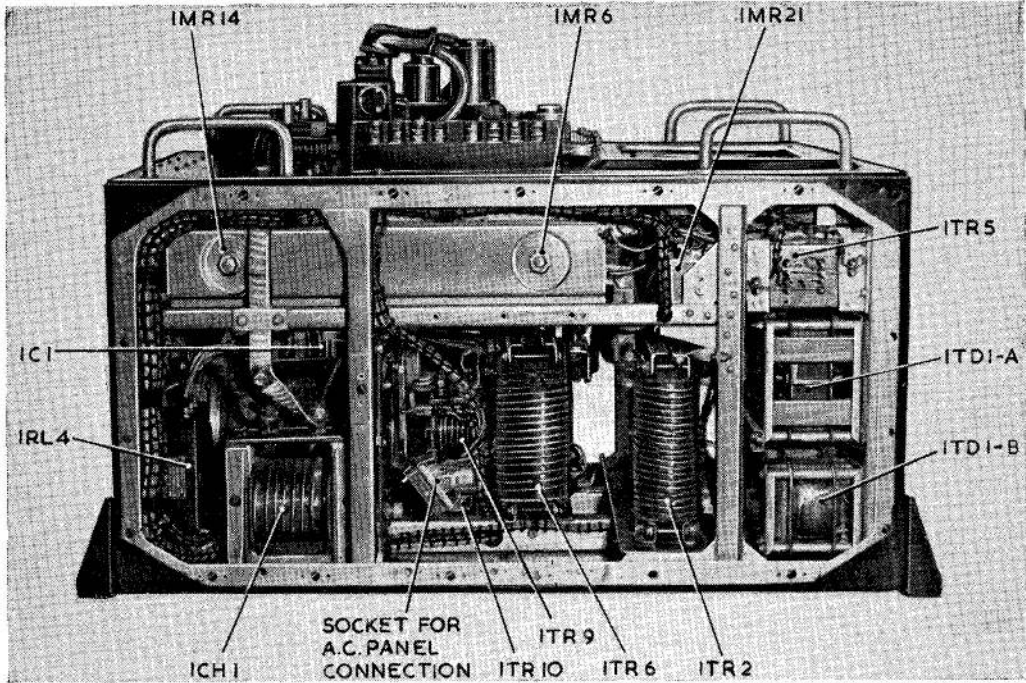

Fig. 9. View with a.c. panel removed

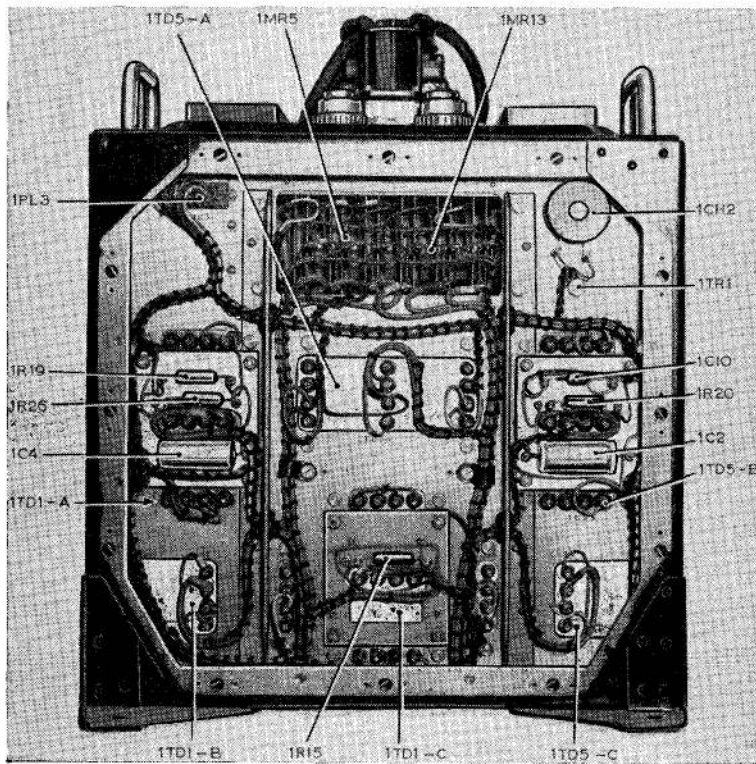

Fig. 10. Rear view of unit

RESTRICTED

through the current sensing transformer 1TR9 and rectifier 1MR7, with a similar signal from the other control unit. When both units are operating normally, the load balancing current from each control unit will cancel out, but if one control unit develops a fault, current will flow through the transductor d.c. control windings in opposite directions, i.e., in one control unit the load balancing current will flow from the pre-amp. stage to the over-voltage stage, whilst in the other control unit, the direction of flow will be from the over-voltage transductor to the pre-amp. transductor. The effect of this out-of-balance current will be to adjust the outputs of the

two d.c. channels, via the pre-amp. control of the booster transductor, so re-establishing a balance of load between the two d.c. channels.

SERVICING

24. This unit should be serviced in accordance with the relevant Servicing Schedule. Servicing consists mainly of inspection for freedom from damage, and security of electrical connections; components which are known to be faulty may be renewed. A complete list of components is given in Table 1.

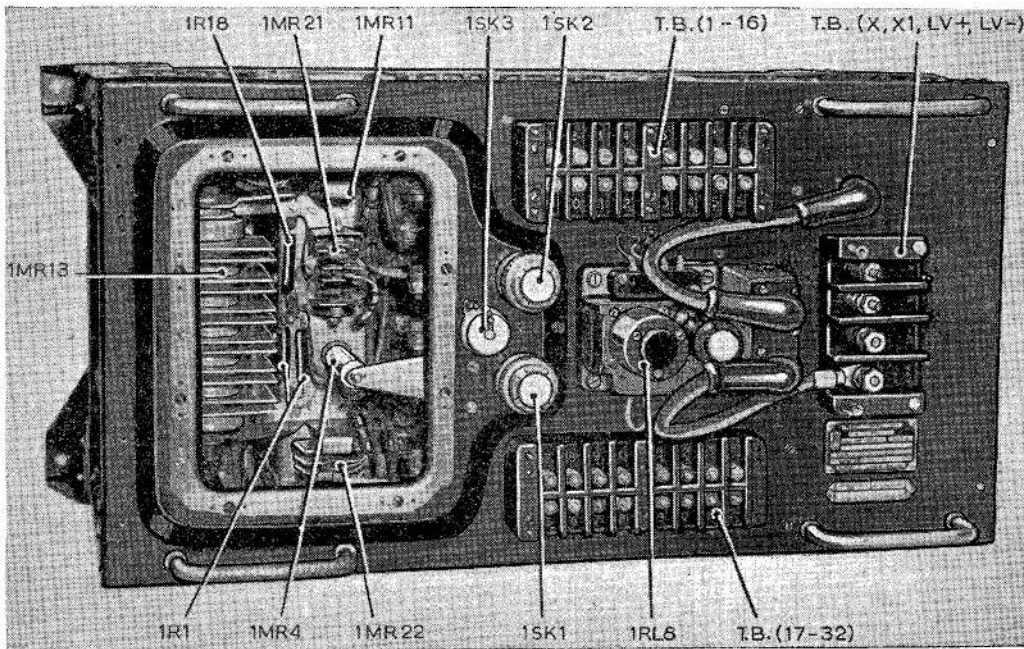

Fig. 11. Plan view of unit

RESTRICTED

Table 1
Circuit component details

Cct. Ref.	Description	Value	Part No.
1TR1	Contacto supply transformer		P1606
1TR2	Excitation transformer		P9504
1TR3	3-phase supply transformer		P8901
1TR5	Signal transformer		P9701
1TR6	Main transformer		P9403
1TR7	Booster transformer		P9503
1TR8	Pre-amp. supply transformer		P9801
1TR9	Current sensing transformer		P9901
1TR10	Load sharing transformer		P8701
2TR1	Current transformer		Part of alternator
3TR1	Current transformer		P8006
3TR2	Compounding transformer		P8006
1TD1	Excitation transductor (3 off)		P9602
1TD2	Pre-amp. transductor		P7202
1TD3	Under-voltage protection transductor		P7004
1TD4	Over-voltage protection transductor		P7004
1TD5	Booster transductor (3 off)		P9602
1TD6	Pre-amp. transductor		P7202
1TD7	Under-voltage protection transductor		P7005
1TD8	Over voltage protection transductor		P7005
1CH1	Choke	0.1 mH	P8801
1CH2	Choke		P9301
1RL1	A.C. protection relay		
1RL2	Field shorting contactor		D12802
1RL3	D.C. protection relay		
1RL4	Thermal relay		D6203/1
1RL5	A.C. line contactor to D.C.		D12601
1RL6	D.C. protection relay		
1RL7	A.C. protection relay		
1RL8	D.C. bus-bar contactor		D12701/1
1RL9	Merz Price relay		
1RL10	Holding relay		
1RL11	Holding relay		

RESTRICTED

Table 1 — continued

Cct. Ref.	Description	Value	Part No.
3RL1	A.C. busbar contactor		
3SW1	A.C. controller switch		D5503
3SW2	D.C. controller switch		D5503
1F1	Fuse	10 amp.	
1F2	Fuse	5 amp.	
1F3	Fuse	5 amp.	
1F4	Fuse	5 amp.	
1ST1	Starter unit	8 ohms	ZA10402
1MR1	Rectifier		
1MR4	Rectifier		
1MR5	Rectifier		
1MR6	Rectifier		
1MR7	Rectifier		
1MR9	Rectifier		
1MR10	Rectifier		
1MR11	Rectifier		
1MR12	Rectifier		
1MR13	Rectifier		
1MR14	Rectifier		
1MR15	Rectifier		
1MR16	Rectifier		
1MR17	Rectifier		
1MR19	Silicon diode rectifier		
1MR20	Rectifier		
1MR21	Rectifier		
1MR22	Rectifier		
1C1	Capacitor	15 μ F	
1C2	Capacitor	1 μ F	
1C4	Capacitor	1 μ F	
1C5	Capacitor	140 μ F	
1C6	Tantalum capacitor	30 μ F	
1C7	Capacitor	140 μ F	
1C8	Capacitor	50 μ F	
1C9	Tantalum capacitor	1 μ F	
1C10	Tantalum capacitor	12 μ F	
1C11	Capacitor	50 μ F	

RESTRICTED

Table 1 — continued

Cct. Ref.	Description	Value	Part No.
1L1	Barretter		
1L2	Barretter		
1SK1	Fixed socket	12-pole, 5A	
1SK2	Fixed socket	12-pole, 5A	
1SK3	Fixed socket	4-pole, 5A	
1PL1	A.C. panel fixed plug		
1PL2	D.C. panel fixed plug		
1PL3	Transducer panel fixed plug		
1RV1	Variable resistance	2.5K, $\frac{1}{2}$ W	
1RV2	Variable resistance	1.5K, $\frac{1}{2}$ W	
1RV3	Variable resistance	2.5K, $\frac{1}{2}$ W	
1RV4	Variable resistance	33 Ω , $\frac{1}{2}$ W	
1RV5	Variable resistance	33 Ω , $\frac{1}{2}$ W	
1RV6	Variable resistance	33 Ω , $\frac{1}{2}$ W	
1RV8	Variable resistance	750 Ω , $\frac{1}{2}$ W	
1RV9	Variable resistance	100 Ω , 1W	
1RV10	Variable resistance	33 Ω , $\frac{1}{2}$ W	
1RV11	Variable resistance	33 Ω , $\frac{1}{2}$ W	
1RV12	Variable resistance	25 Ω , $\frac{1}{2}$ W	
1RV13	Variable resistance	100 Ω , 1W	
3RV1	Variable resistance	25 Ω , $\frac{1}{2}$ W	
3RV2	Variable resistance	25 Ω , $\frac{1}{2}$ W	
1R1	Resistor (Two 10K, 4.5W in parallel)	5K, 9W	
*1R2	Resistor	18 Ω , 1.5W	
1R3	Resistor	110 Ω , 3W	
1R4	Resistor	220 Ω , 3W	
1R5	Resistor	150 Ω , 3W	
1R7	Resistor	100 Ω , 1 $\frac{1}{2}$ W	
1R8	Resistor	12 Ω , 1 $\frac{1}{2}$ W	
1R9	Resistor	47 Ω , 3W	

* Pre-mod. B/470. 8.2 Ω , 3W.**RESTRICTED**

Table 1 — *continued*

Cct. Ref.	Description	Value	Part No.
1R10	Resistor	150 Ω , 3W	
1R11	Resistor	180 Ω , 3W	
1R12	Resistor	0.001 Ω	
1R13	Resistor	68 Ω , 1½W	
1R14	Resistor	25 Ω , 1½W	
1R15	Resistor	620 Ω , 3W	
1R17	Resistor	330 Ω , 3W	
1R18	Resistor	100 Ω , 4.5W	
1R19	Resistor	330 Ω , 3W	
1R20	Resistor	820 Ω , 3W	
1R21	Resistor	120 Ω , 3W	
1R22	Resistor	82 Ω , 3W	
1R23	Resistor	50 Ω , 3W	
1R24	Resistor	50 Ω , 1½W	
1R25	Resistor	50 Ω , 1½W	
1R26	Resistor	390 Ω , 3W	
1R28	Resistor	82 Ω , 3W	
1R29	Resistor	1.2K, 3W	
1R30	Resistor	25 Ω , 1½W	
1R31	Resistor	1.2K, 3W	
1R32	Resistor	1K, 3W	
1R33	Resistor	25 Ω , 1½W	
1R34	Resistor	50 Ω , 1½W	
1R35	Resistor	25 Ω , 1½W	
1R36	Resistor	25 Ω , 1½W	
1R37	Resistor	50 Ω , 1½W	
1R38	Resistor	50 Ω , 1½W	
1R39	Resistor	200 Ω , 3W	
1R40	Resistor	180 Ω , 1½W	
1R41	Resistor	180 Ω , 1½W	
1R42	Resistor (Three 16 Ω in parallel)	5.35 Ω	

RESTRICTED

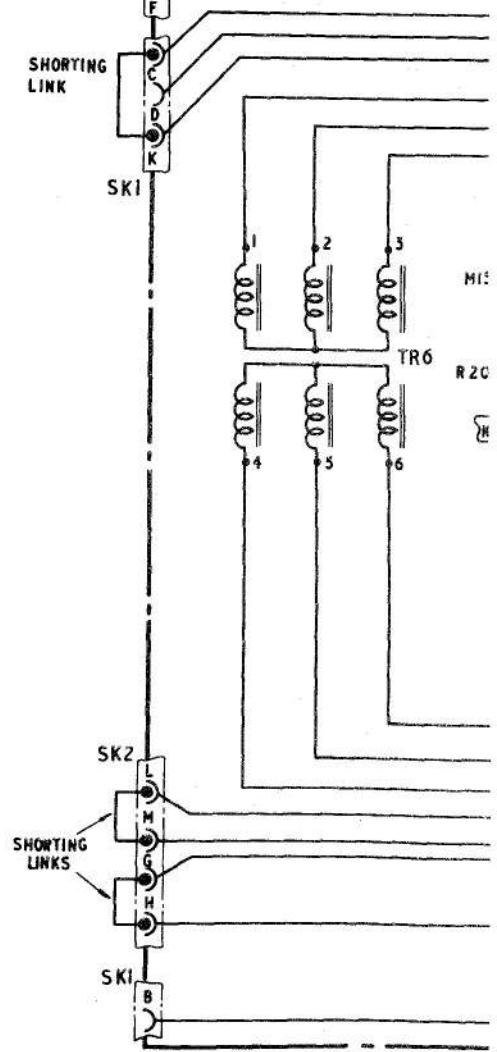
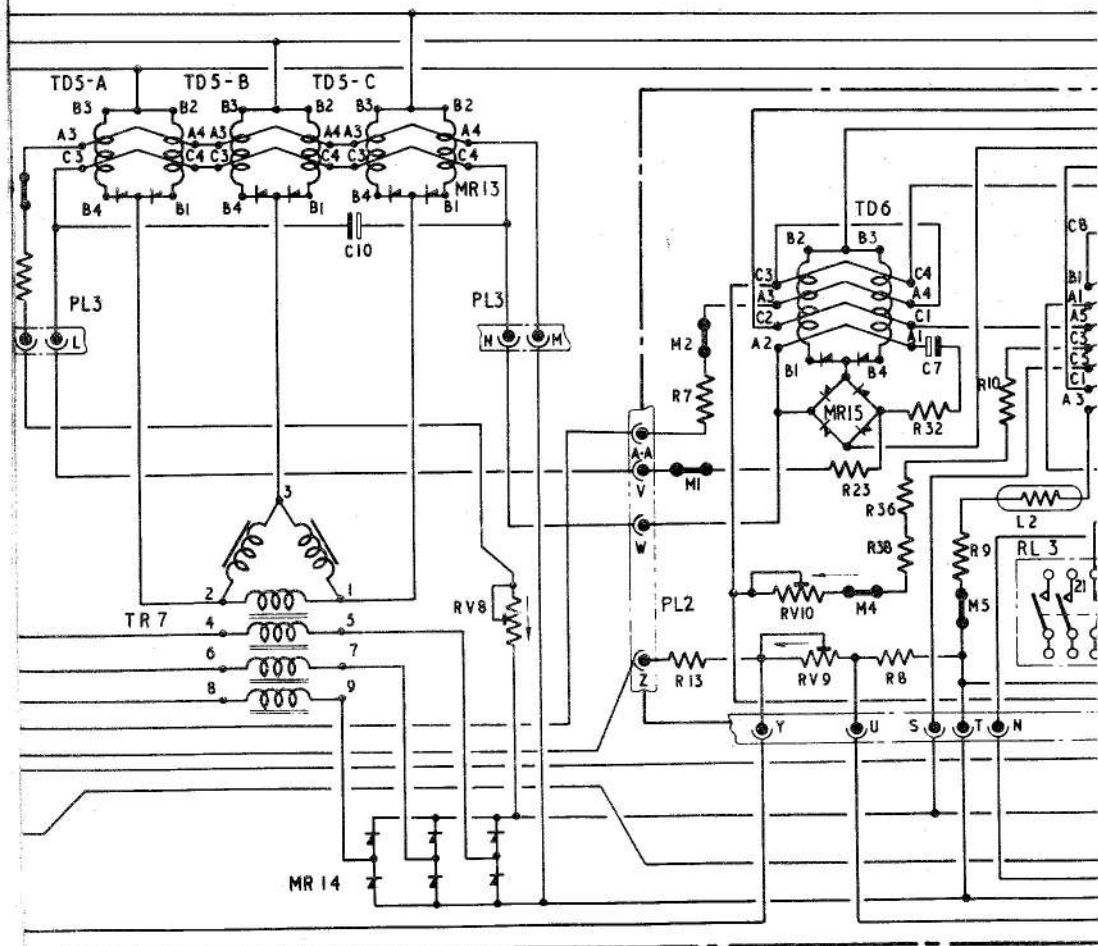
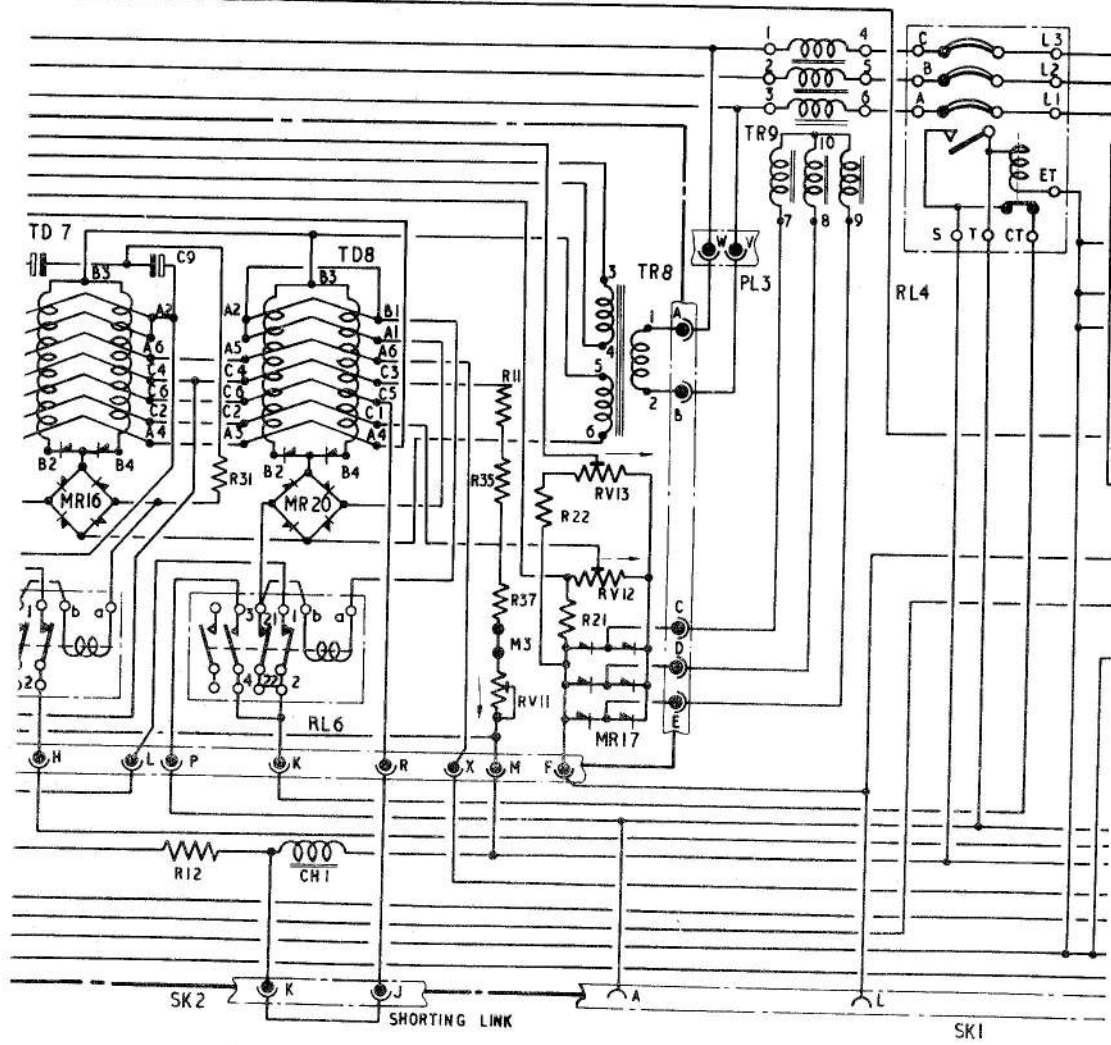

Fig.12



Composite circuit d
RESTRICTED



Diagram

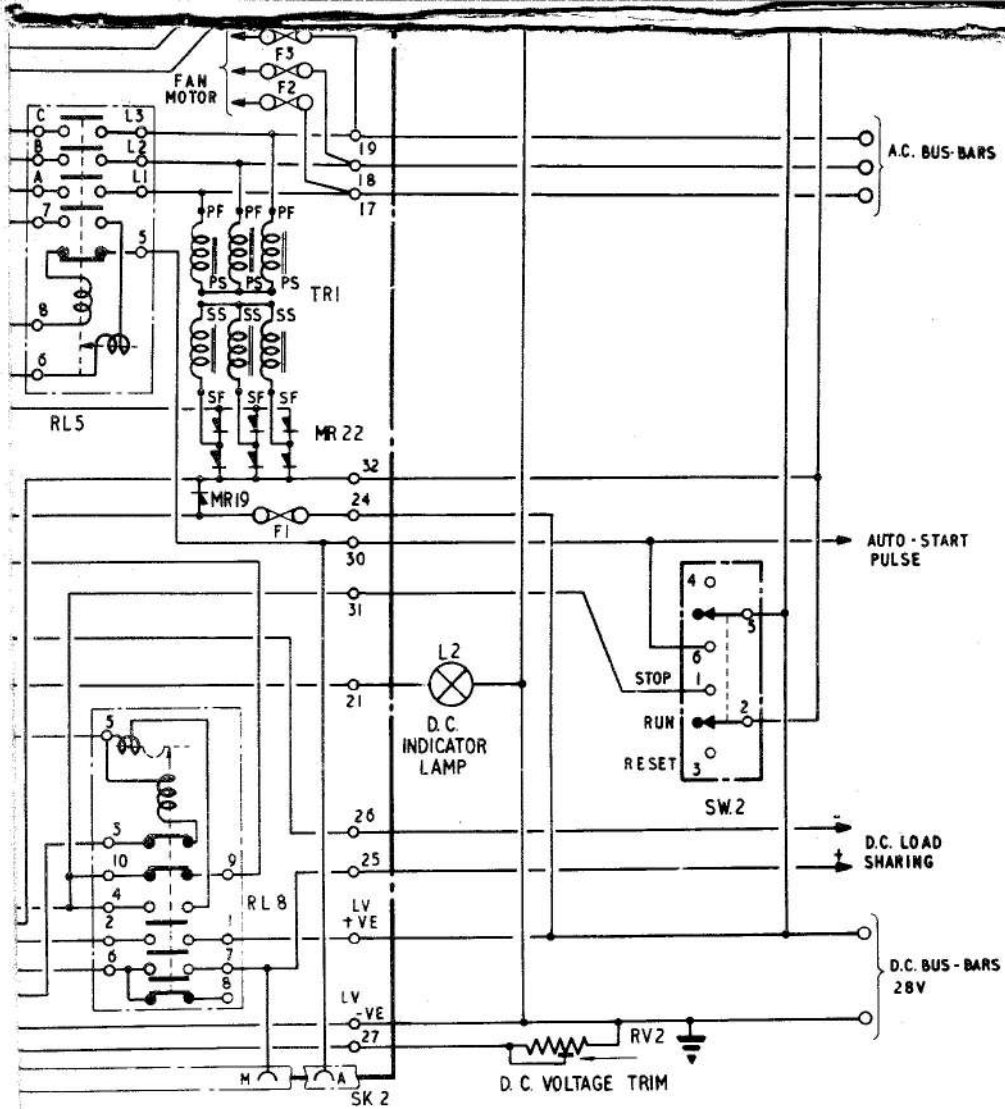
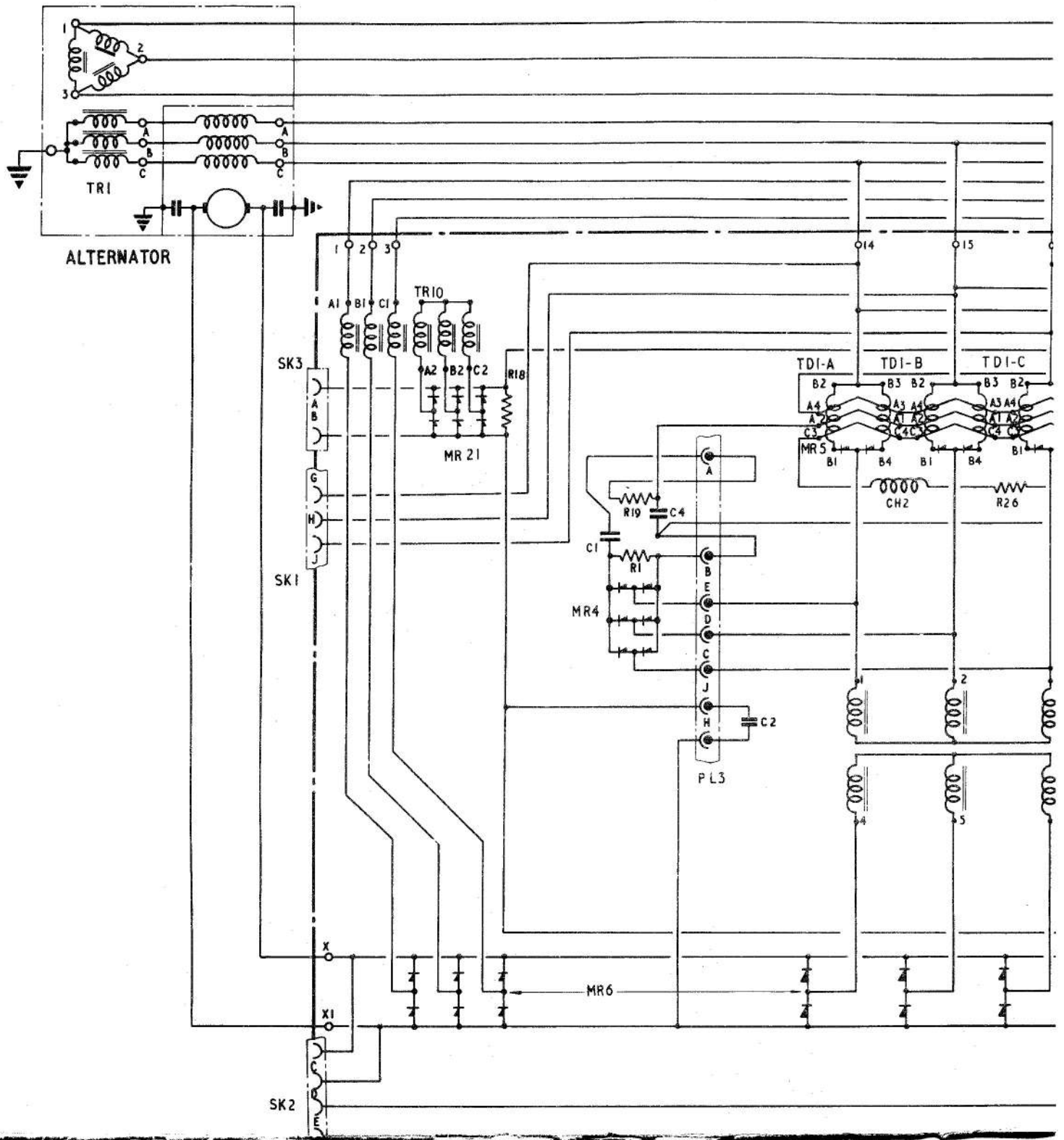
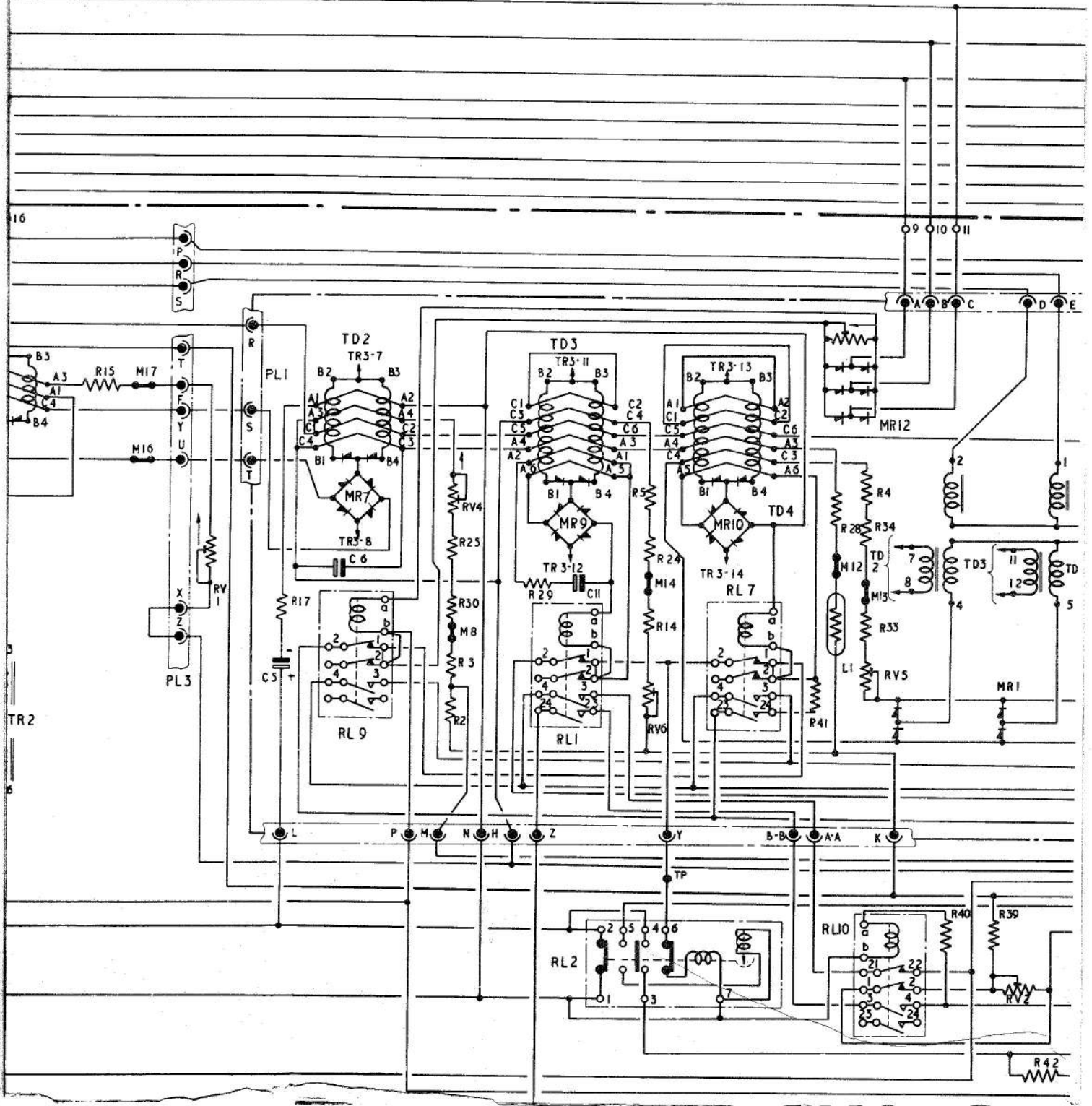

Fig. 12



16



116

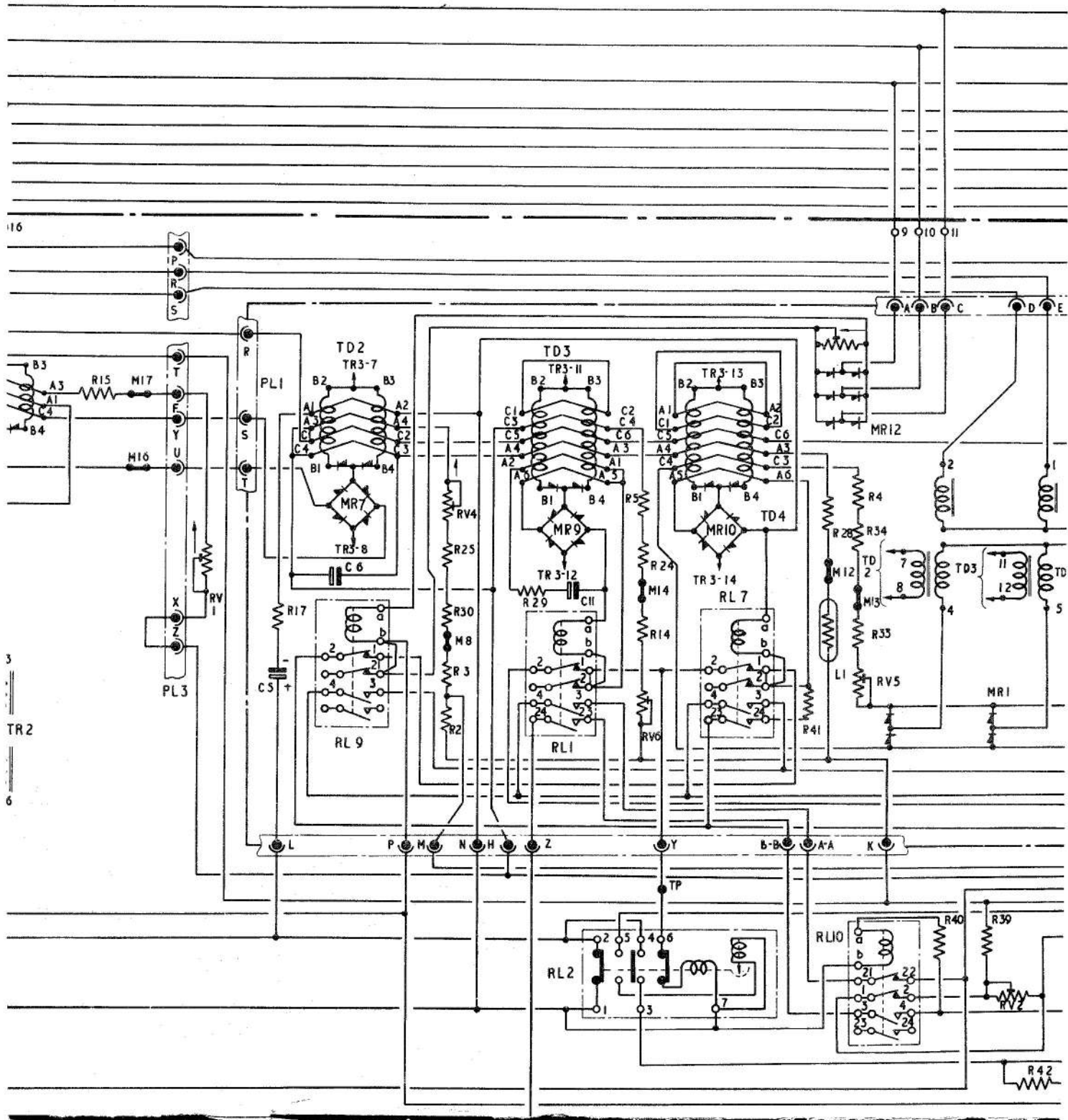

3

TR2

6

A.P. 4343B, Vol. I, Book 2, Sect. 8, Chap. 10
 A.L. 38, Dec. 60

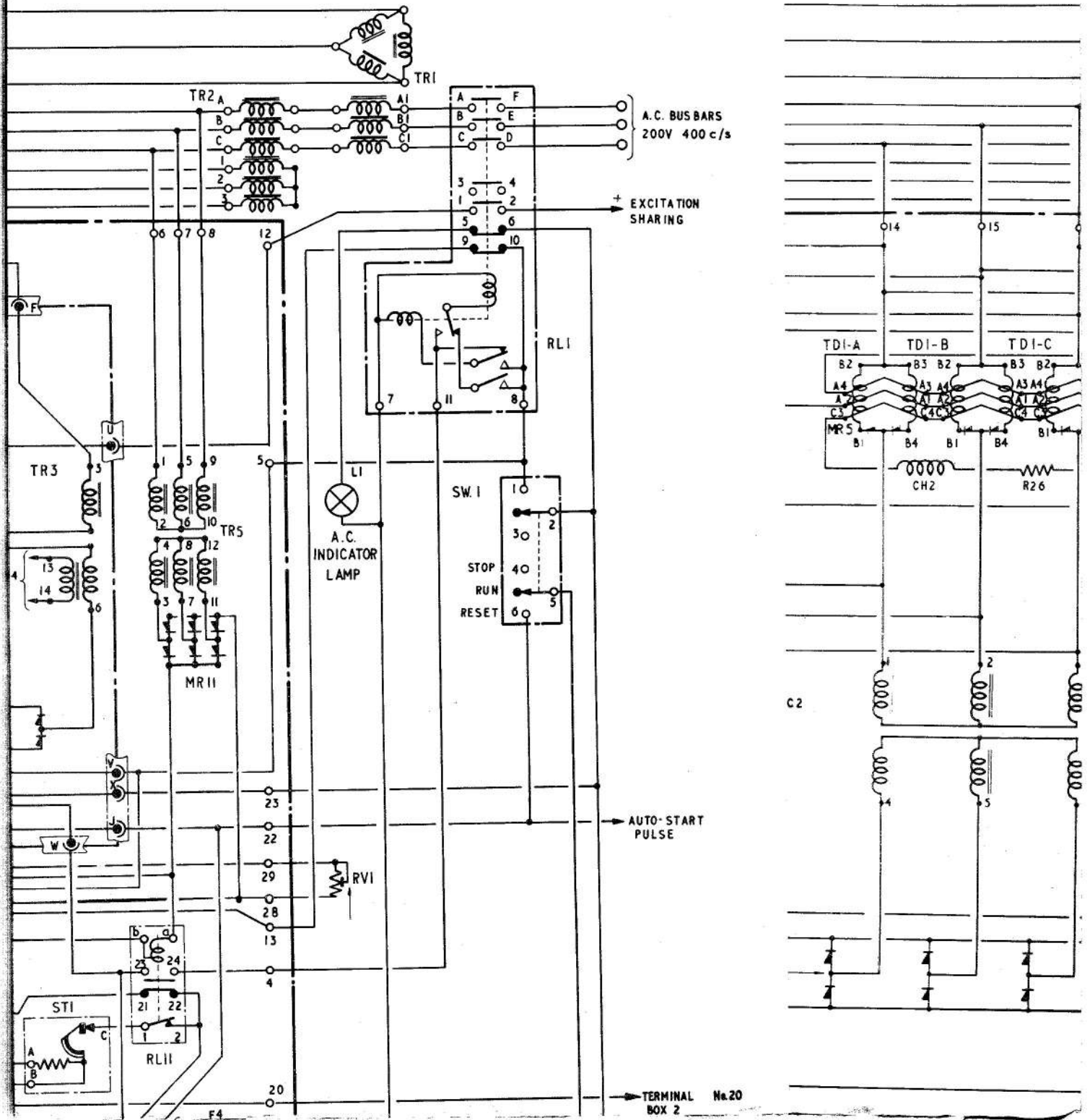

This file was downloaded
from the RTFM Library.
Link:www.scottbouch.com/rtfm

Please see site for usage terms,
and more aircraft documents.

