

Now 113D-07134-1

Chapter 11

FREQUENCY AND LOAD CONTROLLER, TYPE 41 (E.E. Type AE 7507)

LIST OF CONTENTS

	Para.		Para.
<i>Introduction</i>	1	Operation	
		<i>Frequency above normal</i>	20
Description		<i>Out of balance load condition</i>	25
<i>General</i>	3	Installation	30
<i>Base assembly</i>	4	Servicing	31
<i>Bracket assembly</i>	5	Testing	
<i>Terminal board final assemblies</i>	13	<i>General</i>	32
<i>No. 2 sub-assembly</i>	16	◀ <i>Wiring test</i>	33
<i>Transformers</i>	18	<i>Frequency circuit test</i>	34
<i>Capacitors</i>	19	<i>Real load sensing test</i>	36
		<i>Insulation test</i>	38 ▶

LIST OF ILLUSTRATIONS

	Fig.		Fig.
<i>General view of controller without cover</i>	1	<i>Wiring diagram</i>	4
<i>Typical frequency discriminator circuit</i>	2	<i>Test circuit</i>	5
<i>Real load sharing circuit</i>	3	<i>Max/min, input/output characteristics</i>	6
		◀ <i>Insulation test circuit</i>	7 ▶

LEADING PARTICULARS

<i>Frequency and load controller, Type 41</i>	Ref. No. 5UC/6104
Connections	
<i>2-pin breeze plug</i>	Ref. No. 5X/6326
<i>12-pin breeze plug</i>	Ref. No. 5X/6184
<i>Ambient temperature range</i>	-65°C to +70°C
Control	
<i>Frequency</i>	400 c/s + 1%
<i>Load sharing</i>	Within 3 kW from the average load of the system
<i>Altitude (max. operating)</i>	60,000 ft.
<i>Weight</i>	8.6 lb.

RESTRICTED

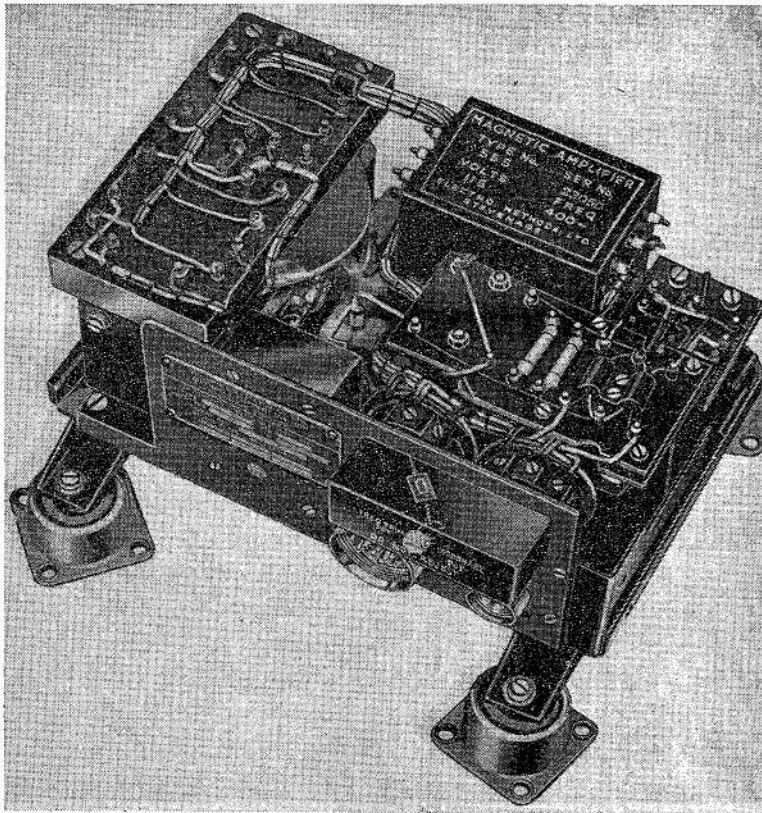

Fig. 1. General view of controller without cover

Introduction

1. The frequency and load controller is used in multi-generator constant frequency a.c. systems to sense any slight changes in frequency and load conditions, and thereby to trim the generator output quickly to the correct values.

2. To understand the function of this unit it is necessary to know something of the electrical power system in which the unit is installed. Reference should be made to A.P.4343, Vol. 1, Sect. 2, Chap. 6, which gives a full description of the 40kVA, English Electric constant frequency a.c. system.

DESCRIPTION

General

3. The unit has been designed to act as a fine trimmer of frequency and load when these quantities vary slightly from the operating limits as given in Leading Particulars.

Base assembly

4. This forms the main mounting platform for the electrical components of the unit. The base is fabricated and includes features

such as the mounting straps to which the anti-vibration mounts are fitted, and anchor plates fitted with stiffnuts for fastening the pillars securing No. 2 sub-assembly and for securing the bracket assembly.

Bracket assembly

5. The bracket itself is fabricated and houses the following parts. Two ferrite core inductors, a rectifier panel assembly, terminal block assembly, a terminal board final assembly, and a metrosil disc.

6. Each ferrite core inductor comprises a high permeability shell housing, a ferrite core, and a single winding fitted inside the core.

7. Each inductor is part of a tuned circuit, calibrated to resonate at certain frequencies in the frequency discriminator circuit.

8. The rectifier panel assembly comprises a paxolin rectifier panel to which are fitted four terminal lugs and two silicon junction diodes. The connections to the diodes are made via soldered joints on the terminal lugs, the inner two being the positive lines. The diodes provide half-wave rectification to the

RESTRICTED

rise or fall frequency change signals in the frequency discriminator circuit, the rectified signals being passed directly to the magnetic amplifier control windings.

9. The terminal block assembly consists of a paxolin terminal board housing and four terminal lugs. It is mounted on the inside of the bracket, and is used to terminate the leads from each inductor assembly.

10. The terminal board final assembly is an encapsulation of resistors, capacitors, and silicon diodes, and fits on the top of the bracket above the inductors. Connections to the electrical components of the assembly are made via soldered joints on turret lugs fitted within the encapsulation.

11. A metrosil disc is fitted underneath the terminal board final assembly and is electrically connected across one phase of the constant speed drive unit servo motor. Its purpose is to damp the signals passed to the c.s.d. servo motor under transient conditions. Surrounding the metrosil disc, which is very fragile, are two light alloy discs of similar diameter to give mechanical support to the disc. One is fitted to the top face and the other to the bottom face of the metrosil disc. Finally, two insulation washers with an insulation bush interposed, are placed in the centre and the whole is secured to the terminal board final assembly.

12. In the centre of the bracket a grommet is fitted, through which are passed all the leads to the terminal block assembly.

Terminal board final assemblies

13. These are fitted to the base assembly one above the other next to the frequency and load trimming potentiometers.

14. The upper assembly contains a calibrated capacitor assembly, and this is common only to the unit to which it is fitted.

It is part of one of the tuned circuits of the frequency discriminator, the capacitors being known as "padding capacitors".

15. The lower assembly is not encapsulated and houses one 3.3 ohm resistor and three terminal lugs (two being inter-connected). The resistor is known as the current transformer (c.t.) load resistor and its installation, as its name implies, is in the real load sensing circuit, i.e. the c.t. resistor is connected in parallel with the external current transformer used for detecting the real load current in the generator feeders.

No. 2 sub-assembly

16. The No. 2 sub-assembly consists of the electrical components in the output circuit of the magnetic amplifiers.

17. The two diverter potentiometers for balancing the magnetic amplifier are fitted to the centre part of the bracket assembly which forms the main mounting for the components. At the top an assembly of resistors and silicon diodes form No. 5 component pack which is attached to the bracket. This No. 5 component pack is not encapsulated, and the silicon junction diodes and 4.7 kilohm resistors together with all the terminal connections can be seen from the top of the unit. The potentiometers will be hidden from view by this component pack.

Transformers

18. These are 115V step down types, one is fitted adjacent to the magnetic amplifier and the other behind the bracket under the magnetic amplifier balancing potentiometers. One, having two secondary windings of 5V-0-5V, is the input to the frequency discriminator circuit and to the real load sensing circuit. The other provides 26V a.c. to the reference phase of the c.s.d. servo-motor, and at the same time the primary acts as a centre tapped choke to provide the load connection for the push-pull magnetic amplifier.

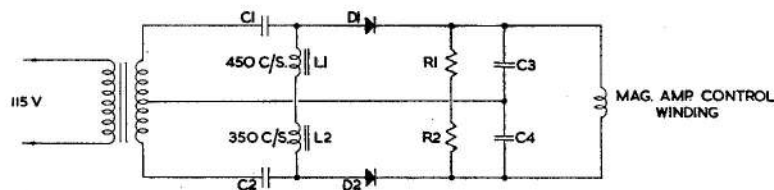

Fig. 2. Typical frequency discriminator circuit

RESTRICTED

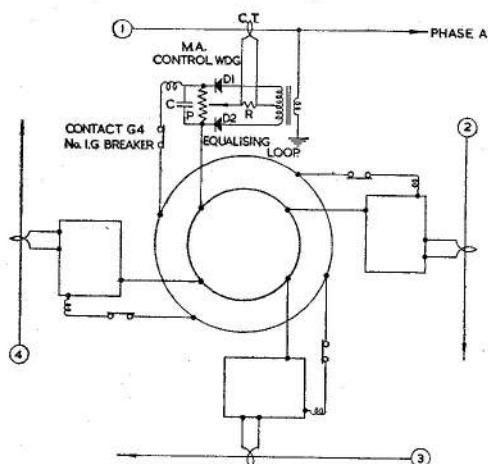

Fig. 3. Real load sharing circuit

Capacitors

19. The capacitors which complete the assembly, are metal cased, polystyrene dielectric types. Two are $0.1 \mu\text{f}$. and one $0.05 \mu\text{f}$. One of each type is positioned in the centre of the unit between the inductors and two transformers, and the other $0.1 \mu\text{f}$. capacitor is situated between the inductors and magnetic amplifier.

OPERATION

Frequency above normal

20. Any rise in frequency change signal is fed into the primary windings of the step down transformer next to the magnetic amplifier (fig. 2). The signal is passed to the frequency discriminator circuit comprising two choke-capacitance circuits, which are tuned for resonance at the upper and lower frequency limits of 450 and 350 c/s respectively, the voltages appearing across the chokes being connected in opposition after being rectified.

21. If we assume that each path has similar response characteristics at 400 c/s the voltage across capacitor C3 and C4 will be equal and opposite, with the result that no current will flow through the magnetic amplifier windings. If the frequency tends towards the resonant frequency of C1, L1 (i.e. above normal), the voltage across L1 will be greater than that across L2 and current will flow through the magnetic amplifier control windings.

22. Conversely, a similar procedure is followed for frequencies under normal, except that the direction of current fed to the magnetic amplifier control windings is reversed.

23. The amplified signal is then fed from the magnetic amplifier to the control phase of the c.s.d. servo-motor and hence the frequency is restored to normal operating range.

24. Between them the c.s.d. governor mechanism and the frequency and load controller keep the frequency within $\pm 1\%$ of the nominal frequency of 400 c/s.

Out of balance load condition

25. In the simplified load sharing diagram (fig. 3) the potential divider 'P' is connected via the diodes D1 and D2, from the secondary windings of the step down transformer (5V-0-5V), whose primary is between phase A and earth of the generator supply. The electrical centre of 'P' is connected to the centre tapping of this transformer through the load resistor 'R'. The current transformer which is used to sense any out of balance load in the line output from each generator, is connected across this load resistor.

26. Initially ignoring any effect by the current transformer for each half-cycle, it will be seen that current may flow in one rectifier loop but will be blocked by the rectifier in the other loop. It follows then, that potentials of 10-volts produced across 'P' for each half-cycle will be equal and opposite, and that the net voltage appearing across capacitor C will be zero for a complete cycle.

27. If we now consider the effect of the current transformer across the load resistor 'R', the current flowing from it will produce a voltage across 'R'. We will assume this to be 3V. Depending in which direction the current is flowing, the 3V applied will be added to the voltage in one rectifier loop and subtracted from the voltage in the other. For a complete cycle then, a d.c. voltage will appear across the capacitor equal to $\sqrt{2} \times$ the difference between the voltages, i.e. $\sqrt{2}(13-7) = 8.5\text{V}$.

28. This voltage is put through a smoothing circuit and the smoothed d.c. output applied to the magnetic amplifier control windings which ultimately supply an amplified signal to the c.s.d. servo-motor.

29. This supply to the control windings of the magnetic amplifier is also connected into an equalizing loop, to which all the other generator frequency and load controllers installed are connected. If one machine tends to take on real load, the voltage across

RESTRICTED

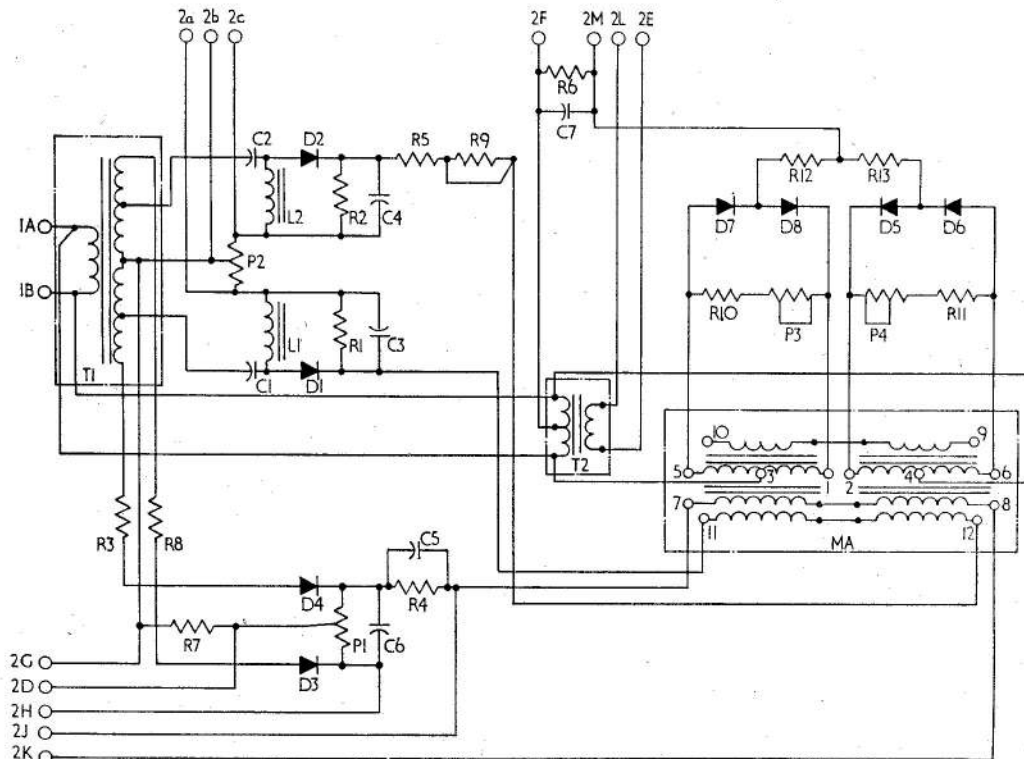

C1 CAPACITOR, ASSY. TUNED
C2 CAPACITOR, 0.1 MFD
C3 CAPACITOR, 0.1 MFD
C4 CAPACITOR, 0.1 MFD
C5 CAPACITOR TANTALYTIC 5 MFD
C6 CAPACITOR TANTALYTIC 5 MFD
C7 CAPACITOR 5 MFD
D1 } SILICONE DIODE TYPE ZS20B
D2 }
D3 }
D4 } SILICONE DIODE TYPE ZS10B
D5 }
D6 }
D7 } SILICONE DIODE TYPE ZS10B
D8 }
L1 INDUCTOR 1.25 HENRYS
L2 INDUCTOR 1.25 HENRYS
MA MAGNETIC AMPLIFIER
P1 POTENTIOMETER, 10,000Ω

P2 POTENTIOMETER, 250Ω
P3 POTENTIOMETER, 2,500Ω
P4 POTENTIOMETER, 2,500Ω
R1 RESISTOR, 150,000Ω
R2 RESISTOR, 150,000Ω
R3 RESISTOR, 270Ω
R4 RESISTOR, 18,000Ω
R5 RESISTOR, 100,000Ω
R6 RESISTOR METROSIL DISC
R7 RESISTOR, 3.3Ω
R8 RESISTOR, 270Ω
R9 RESISTOR, 47,000Ω
R10 RESISTOR, 4,700Ω
R11 RESISTOR, 4,700Ω
R12 RESISTOR, 120Ω
R13 RESISTOR, 120Ω
T1 TRANSFORMER, 115V/5V-0.5V/5V-0.5V
T2 TRANSFORMER, 115V/26V

Fig. 4. Wiring diagram

INSTALLATION

its magnetic amplifier will increase proportionately and the voltage across the other magnetic amplifiers will be decreased by one-third of this value. Current will circulate around the equalizing loop through the magnetic amplifier controls winding to correct the change.

30. The unit is mounted on the four anti-vibration mountings one at each corner of the feet, and each should be secured in position with four 2 B.A. screws and four lock-washers. Finally the electrical connections are made from the aircraft electrical system through socket/plug connectors to the unit.

RESTRICTED

SERVICING

31. Without removing the unit from the aircraft, the only servicing necessary is routine inspection for security, mechanical damage, and corrosion. There are no moving parts within the unit, and as such no internal servicing should be necessary.

Note . . .

◀ The locknut, which secures the potentiometer to the case, should be tightened to a torque of 35 lb. in., and spindle locknut should be tightened to 15 lb. in. Two spanners should be used, one to hold the potentiometer locknut, whilst using the other to tighten the spindle locknut. Care should be taken not to disturb the setting of the potentiometer whilst performing the locking operation. ▶

TESTING

General

32. Connect the unit to the test circuit as

shown in fig. 5. A current transformer such as the Type AE.5703 Mk. 2 (Ref. No. SUB/6863) described in A.P.4343B, Vol. 1, Book 3, Sect. 19, Chap. 18, is incorporated for certain tests. The transformer should be modified by passing a cable capable of carrying 3A through the core and winding on 35 primary turns in the manner outlined in the test circuit. A variable resistor 45 ohm, 500W should be connected in series with this primary winding. The method of test is given in the following paragraphs.

Wiring test

33. Measure the resistance between terminals 1A and 1B. This must be 13 ± 1.5 ohms. Measure the resistance between terminals G and D. This must be 3.3 ± 0.4 ohms.

Frequency circuit tests

34. With the unit connected to the test

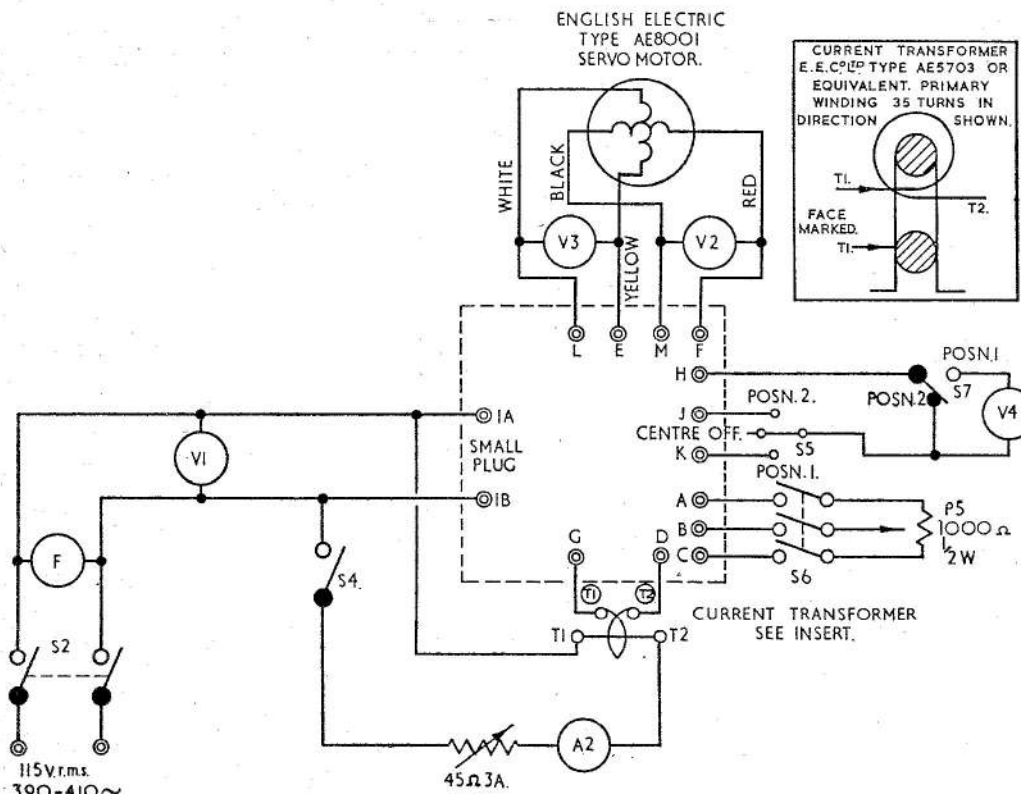

Fig. 5. Test circuit

RESTRICTED

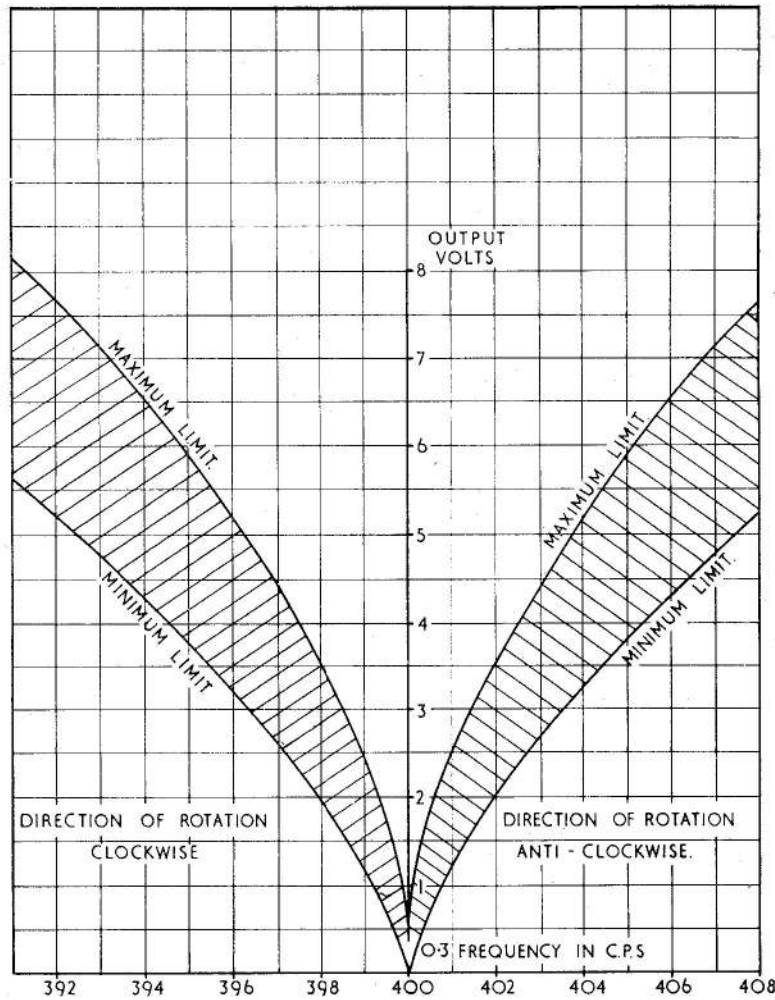

Fig. 6. Max/min, input/output characteristics

circuit (fig. 5) as shown, apply 115V a.c. 400 c/s to pins 1A and 1B by switching on S2. Note that the servo-motor does not operate and that zero voltage is recorded on V4. Vary the frequency of the supply to 390 c/s and the servo-motor should rotate in a clockwise direction when viewed from the drive end, and conversely when the frequency is raised from 400 c/s the servo-motor should rotate in a counter-clockwise direction. The voltage reading on V2 should rise with each change in frequency according to the magnitude of the change and should lie within the limits shown in fig. 6. At 400 c/s V2 should not indicate more than 0.3 volts. Throughout

each test V3 should give a constant reading of 25 ± 3 volts a.c.

35. If the unit functions correctly during the above test the frequency discriminating circuit may be said to be serviceable.

Real load sensing test

36. With the unit still connected to the test circuit the load sensing circuit should be checked as follows. With the supply to pins 1A and 1B set to 115 V, a.c. 400 c/s check that the servo-motor does not operate and that V4 reads zero. Switch on S5 to position 1, S7 to position 2, and close S4. Adjust the

RESTRICTED

current through A1 to 2.5 amp. Voltage V2 should now indicate between 5.5 and 7.5 volts and the servo motor should rotate counter-clockwise at drive end. Switch S5 to position 2 and S7 to position 1. Adjust the current through A1 to 2.5 amp. again and voltmeter V4 should indicate between 1.25 to 1.4 volts.

37. If the unit functions correctly during the above test the real load sensing circuit can be said to be serviceable.

Insulation test

38. Measure the leakage current using a 0-50 μA industrial grade ammeter or multi-meter type 12889 with a 0.5 megohm ($\frac{1}{4}\text{W}$) resistor in series with the positive probe as shown in fig. 7. Connect the test circuit (fig. 7) to a d.c. supply variable between zero and 28V. Increase the voltage gradually from

zero to 28V. The leakage current should not exceed 1.4 μA when this voltage is applied in turn between each designation shown and the remainder

- (1) pins 2L, 2G (plug 2)
- (2) pin 1A (plug 1)
- (3) frame

Before removing test circuit decrease voltage gradually to zero.

Note . . .

The locknut which secures the potentiometer to the case should be tightened to a torque of 35 lb. in. Two spanners should be used, one to hold the potentiometer locknut whilst using the other to tighten the spindle locknut. Care should be taken not to disturb the setting of the potentiometer whilst performing the locking operations.

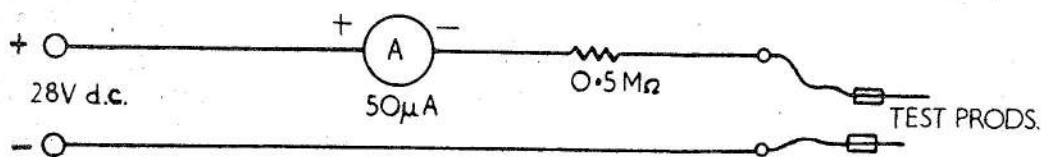

Fig. 7. Insulation test circuit

RESTRICTED

This file was downloaded
from the RTFM Library.

Link: www.scottbouch.com/rtfm

Please see site for usage terms,
and more aircraft documents.

