

Fig. 1. Control panel, E.E. Type AE7002 Mk. 1

Introduction

1. This panel is intended for use with a 20-kVA a.c. generator, in a 200-V, 3-phase, 400 c/s constant frequency system. The three functions of the unit are as follows:—

- (a) To provide a 28-V d.c. supply for the generator exciter bias field.
- (b) To provide interlocking, which prevents the generator and ground supply being connected to the loads at the same time.
- (c) To provide protection against over- and undervoltage and reverse phase sequence and in each event to transfer (in conjunction with the Type AE7003 auxiliary control panel) the control of the generator voltage from the magnetic amplifier voltage regulator to the carbon pile emergency regulator, at the same time as the generator is disconnected from the busbars.

DESCRIPTION

2. The components are housed within a rectangular case, fabricated from light alloy, except for the back of the case which is mild steel. Access is obtained by removal of the front, top and back panels. The unit is divided into upper and lower sections by the partition assembly.

3. In the lower section are mounted the

3-phase transformer, torque switch, two Diamond "H" relays Type R225AIT-1 and R115AIT-1, a resistor panel assembly and cold cathode trigger tube, the pre-set control lock of the overvoltage circuit potentiometer being accessible from the exterior of the unit.

4. Mounted on the partition assembly in the upper section, is the terminal block, two capacitors, resistor block, the full wave rectifier block and rectifier heat sink assembly. Both rectifier block and heat sink assembly are mounted in line with the cooling air supply, which enters and leaves the unit through manacle flange ducts, at each end of the unit.

INSTALLATION

5. The panel may be mounted at any angle and in any position convenient for wiring and accessible for inspection. It is attached by four 2 B.A. round-head screws, which fit through the feet, situated at each end of the unit.

OPERATION

Overvoltage circuit

6. This comprises a full-wave rectifier bridge, a cold cathode trigger tube, and Diamond "H" relay Type R225AIT-1, together with resistors and capacitors. The circuit is fed from a 170-V tapping on the transformer. When the a.c. generator voltage

RESTRICTED

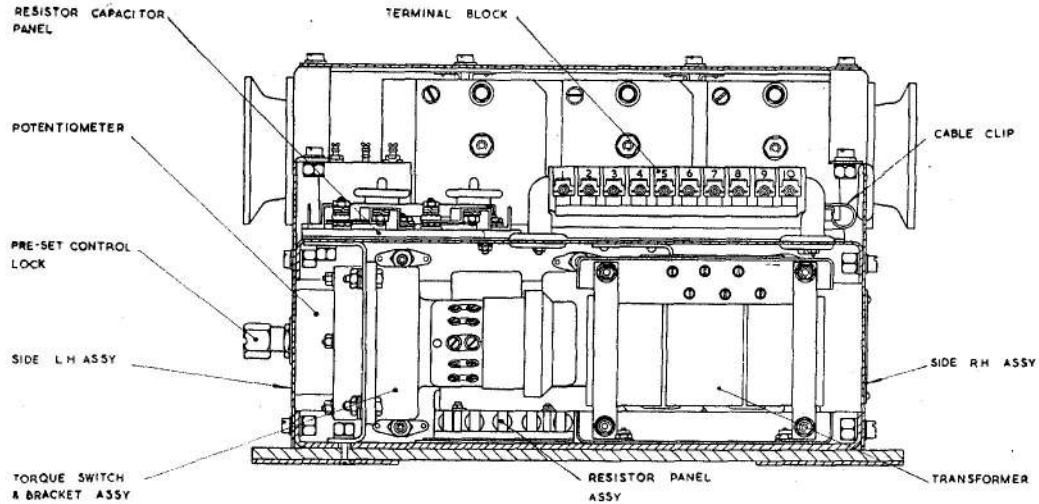

Fig. 2. Front view with front cover and flanges removed.

rises to 215 V the trigger tube fires, energizing the overvoltage relay coil OVR/2 which closes contact OVR-1—this completes a holding circuit for the relay and extinguishes the trigger tube—also opening the contacts OVR-2. The latter removes the supply current through terminal 4, to the transfer relays of the Type AE7003 auxiliary control panel. This transfers control of the a.c. generator voltage, from the Type AE7506 and AE7511 magnetic amplifier voltage regulator to the carbon pile emergency regulator, and trips the contactor Type AE5354, disconnecting the generator from the busbars.

The generator must be run down before the relay drops out.

Undervoltage circuit

7. This circuit comprises a torque switch, which functions as an undervoltage relay. The torque switch is fed from a 115-V tapping on the transformer. When the a.c. generator voltage drops below 167 V, the torque switch operates, opening the undervoltage relay contacts, which removes the supply current through terminal 10 to the transfer relays of the Type AE7003 auxiliary control panel. This transfers control of the a.c. generator

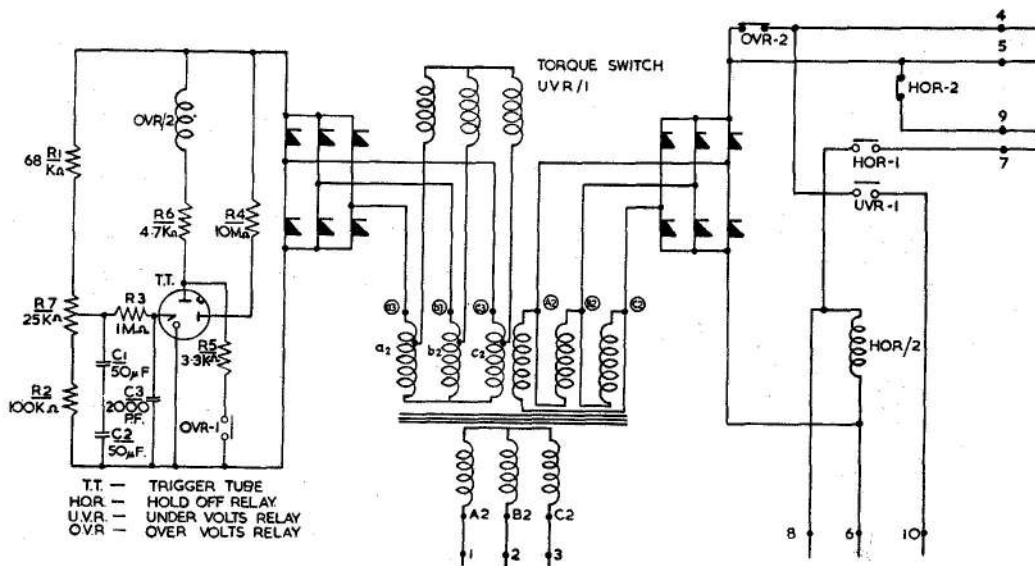

Fig. 3. Schematic wiring diagram

RESTRICTED

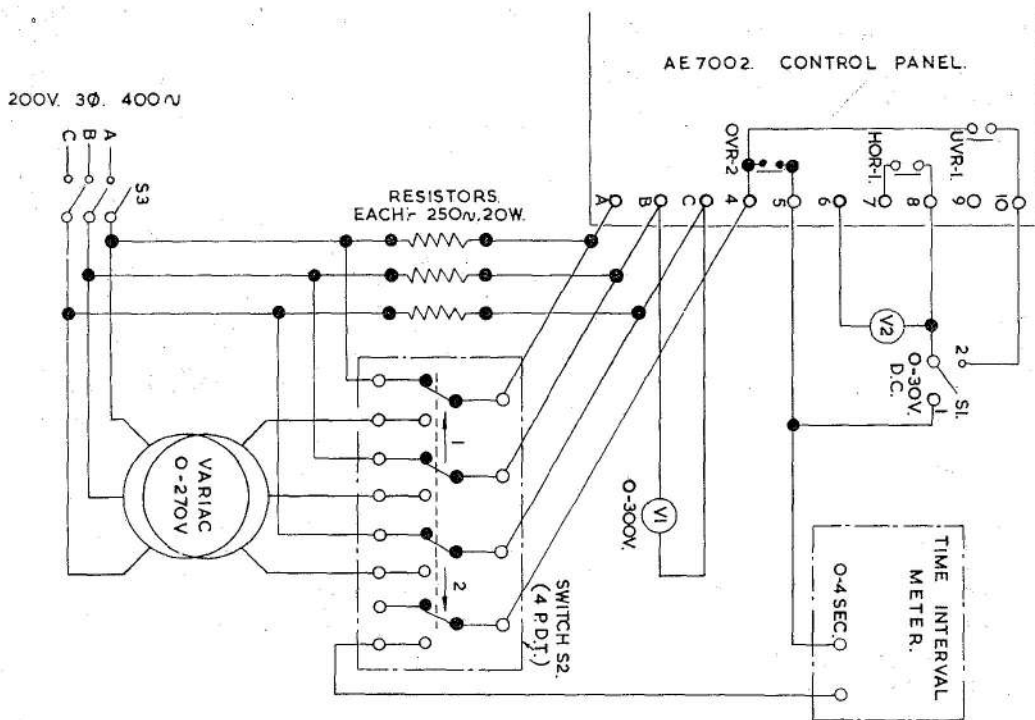

Fig. 4. Test circuit

voltage, from the Type AE7506 and AE7511 magnetic amplifier voltage regulator, to the carbon pile emergency regulator (*para.* 6). The torque switch is also sensitive to phase-sequence, that is relay contact UVR-1 will not close, unless the correct phase sequence is applied to the unit, the system will run up on the carbon pile and the contactor Type AE5354 will not close.

Bias field supply

8. The bias field supply to the a.c. generator is fed through terminals 5 and 6, from a 20-V tapping on the transformer and via a full-wave rectifier bridge.

Hold-off relay

9. This relay, a Diamond "H" Type R115AIT-1, is fed from terminal 8, and when

energized the hold-off relay contact HOR-1 is closed, which puts a supply on the trip coil of the Type AE5354 contactor through contact HOR-1 (normally open) and terminal 7; a second (normally closed) contact HOR-2 opens interrupting the supply from the transformer rectifier unit to the close coil of the contactor Type AE5354. The hold-off relay provides an interlock with the ground supply unit, this ensures that the contactor Type AE5354 cannot be closed if the ground supply is connected.

SERVICING

10. Ensure that the mounting screws are secure and all exterior screws on the unit tight. Examine leads for chafing and deterioration of insulation. Inspect the case for signs of corrosion and damage.

Terminals to which meter is connected		Meter Readings	Circuit Under Test
+ ve	- ve		
6	8	140 ohms \pm 10 ohms	Hold-off relay coil
A	B	7 ohms \pm 0.9 ohms	Transformer
B	C	7 ohms \pm 0.9 ohms	Primary
C	A	7 ohms \pm 0.9 ohms	Windings

RESTRICTED

TESTING**Continuity test**

11. To test for continuity, connect a Type D or F test meter to the terminals shown on chart on previous page when the readings indicated should be obtained.

Overvoltage test

12. The overvoltage circuit is to operate at not less than 215 V (line) applied. The operating point is varied by means of the trimmer, accessible on the outside of the unit and checked by raising the applied voltage gradually from zero. It should be noted that after an operation, the voltage must be removed for 30 seconds before repeating the test.

Functioning Tests

13. For the following tests connect the panel into the circuit shown in fig. 4. It should be noted that the overvoltage relay is to be set once only as detailed in para. 12.

(1) Transformer Rectifier unit

Check the output appearing across terminals 5 and 6 is $28 \text{ V} \pm 2 \text{ V}$ d.c. with 200 V input, terminal 5 is positive.

(2) Hold-off relay

Close switch S3, switch S1 to position 1 and switch S2 to position 2. Raise the a.c. line voltage slowly from zero until the hold-off relay "pulls in", as indicated by the closing of contact HOR-1. Then decrease the line voltage slowly until the hold-off relay "drops-out". The relay is to "pull in" at less than 20 V and "drop-out" between 1 V and 7 V (voltages indicated on V2).

(3) Undervoltage relay

(a) Close switch S1 and S2 to position 2 and close S3. Raise the a.c. line voltage slowly until the undervoltage relay "pulls in" as indicated by the closing of HOR-1. Now reduce the line voltage until the undervoltage relay "drops-out" as indicated by the opening of contact HOR-1. The undervoltage relay is to

"pull in" at $(175 + 10) \text{ V}$, and "drop out" at $(167 + 10) \text{ V}$, indicated on V1.

(b) Verify that the phase sequence of the supply is correct. Reverse the phase sequence of the a.c. supply and raise the line voltage swiftly to 260 V on (V1) by means of the variac. The undervoltage relay is not to close.

(4) Overvoltage relay

(a) With S1 open, close S3 and switch S2 to position 2. Adjust the variac to give the specified overvoltage on V1.

(b) Change S2 to position 1 and open S3.

(c) After 15 seconds close S3 (the voltage on V1 should be 200 V) and set the time interval meter to "ready".

(d) After a further 30 seconds change S2 to position 2 and note the operating time.

(e) After a further 15 seconds open S3 and reset S2 to position 1. The following overvoltages are to be applied to the panel.

Number of Operations	Overvoltage (Volts)	Mean Operating Time (Sec)
1	260	0.4 ± 0.15
5	235	0.8 ± 0.2
1	222	1.7 ± 0.4
—	214	No operation

The sequence of operations (a) to (e) is to be carried out for each of the voltages specified in the above table. The same sequence should be strictly adhered to even if, owing to error, no reading of operating time is obtained.

Insulation test

14 Using a 500-V insulation resistance tester, measure the insulation resistance between the terminals and the case. The minimum permissible reading should not be less than 5 megohms.

RESTRICTED

○

○

○

○

This file was downloaded
from the RTFM Library.

Link: www.scottbouch.com/rtfm

Please see site for usage terms,
and more aircraft documents.

