

CHAPTER 16
CONTROL UNIT, E.E. TYPE AE 7000, Mk.2

LIST OF CONTENTS

	<i>Para.</i>		<i>Para.</i>
<i>Introduction</i>	1	<i>Overvoltage relay</i>	18
Description		<i>Voltage sensing relay</i>	19
<i>General</i>	2	<i>Transformer and rectifiers</i>	20
<i>Top panel assembly</i>	5	Cooling	21
<i>Relay and bracket assembly</i>	6	Installation	22
<i>Main panel assembly</i>	7	Servicing	23
<i>Rectifier panel assembly</i>	8	Testing	
<i>Resistor panel assembly</i>	9	<i>General</i>	24
Operation		<i>Relay resistance test</i>	26
<i>General</i>	10	<i>Test circuit</i>	27
<i>Control</i>	11	<i>Transformer/rectifier check</i>	28
<i>Exciter control relay</i>	12	<i>Overvoltage circuit check</i>	29
<i>Lockout relay</i>	13	<i>Differential protection relay</i>	
<i>Protection</i>	14	<i>checks</i>	30
<i>Differential protection relays</i>	15	<i>Wiring and d.c. relay checks.</i>	31
<i>Underspeed relay</i>	16	<i>Insulation test</i>	32

Cancelled

LIST OF TABLES

	<i>Table</i>
<i>Wiring and d.c. relay checks</i>	1

LIST OF ILLUSTRATIONS

	<i>Fig.</i>		<i>Fig.</i>
<i>Control unit, Type AE 7000, Mk.2</i>	1	<i>Test circuit diagram</i>	4
<i>General view, showing components</i>	2	<i>Schematic wiring diagram</i>	5
<i>Side view, showing components</i>	3		

RESTRICTED

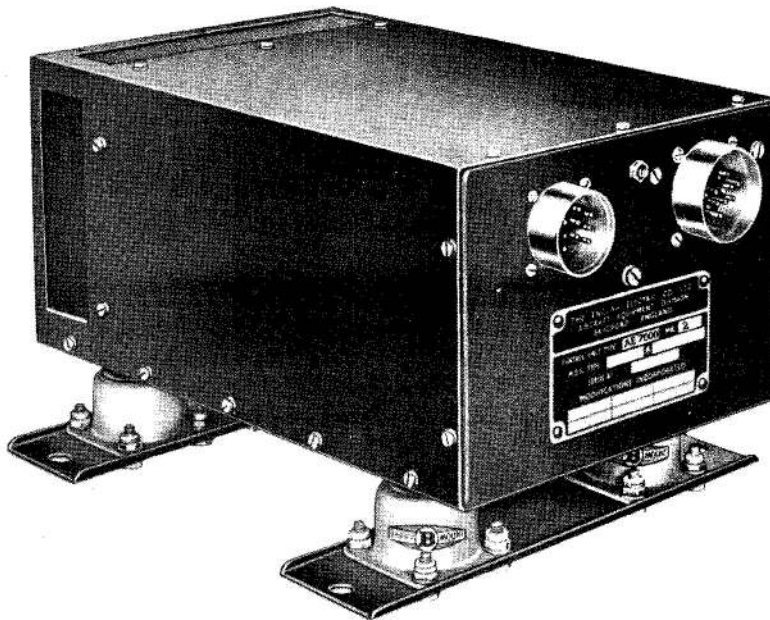

Fig.1 Control unit, Type AE.7000, Mk.2

Introduction

1. The Type AE 7000 Mk.2 control unit is designed for the control and protection of a 9 kVA, 200 volt, 3 phase, 400 c/s a.c. generator in conjunction with a suitable voltage regulator, 3 phase contactor and current transformers.

DESCRIPTION

General

2. The various components of the control unit are grouped together in a number of assemblies, these are mounted on a chassis and the complete assembly is enclosed by a cover. Both the chassis and the cover are of aluminium alloy. The chassis is mounted on four anti-vibration mountings, these are secured in pairs to two channel support brackets. A flexible bonding strip is connected between the base of the chassis and one of the channel support brackets.

3. The electrical connections to the control unit are made by two Plessey standard type plugs, these are mounted on the chassis upright. The plug with the numbered pins providing connection for the 200 volt, 3 phase, supply and that with lettered pins, the low voltage connections. Internal wiring is in P.V.C. equipment wire, Type 2.

4. The control unit consists of the following assemblies, the layout of which can be seen in figs. 2 and 3.

Top panel assembly

5. The top panel assembly comprises the following major components:-

- (a) Top panel - this is a paxolin panel, supported by three alloy pillars which are secured to the chassis base, also by two alloy brackets attached to the chassis upright. A hole in

RESTRICTED

the paxolin allows access to a potentiometer adjusting screw.

(b) Trigger tube bracket - this is an alloy bracket, shaped to provide a mounting for the remainder of the assembly components. It is secured in position to the top panel by three countersunk screws.

(c) Overvoltage relay - this is an hermetically sealed relay, which plugs into a socket fitted to the trigger tube bracket.

(d) Trigger tube - this is a cold cathode trigger tube, which plugs into a valve holder fitted to the trigger tube bracket.

(e) Setting potentiometer - this is a variable trimmer resistance, which is secured to the trigger tube bracket. It has a locknut device, which is used to lock the trimmer screw after adjustment.

(f) Resistors and capacitors - these are secured to a paxolin panel, which is attached to the underside of the trigger tube bracket.

Relay and bracket assembly

6. This assembly is secured to the base of the main chassis by three studs, nuts and spring washers and one screw and locknut. It comprises the following major components:—

(a) Bracket assembly - this consists of two alloy brackets, between which are secured the underspeed relay and exciter control relay. One bracket also carries the associated terminal board.

(b) Underspeed relay - this a latching type relay, secured between the brackets at the base of the assembly.

(c) Exciter control relay - this is a similar type of relay to the underspeed relay and is secured between the brackets at the top of the assembly.

(d) Terminal board - this is a paxolin strip to which is attached the requisite number of terminals to carry the connections from the relays. It is secured to the rear bracket of the bracket assembly by four studs.

Main panel assembly

7. The components which comprise the main panel assembly are fitted to an 'L' shaped paxolin panel secured to the chassis. The major components are as follows:—

(a) Transformer - this is an A.N. type transformer, 20.57 VA, 3 phase, 400 c/s, input 200V (Delta); outputs 21V and 30V (Star). (The 30V output is not used.)

(b) Differential protection relays - three relays of the same type fitted in position on the paxolin panel below the top panel assembly.

(c) Voltage sensing relay - this relay is positioned on the paxolin panel below the top panel assembly.

(d) Lockout relay - this relay is secured in position on the paxolin panel below the terminal board on the relay and bracket assembly.

Rectifier panel assembly

8. The rectifier panel assembly comprises a paxolin panel on which is mounted the main rectifiers, resistors and capacitors in the independent 28 volt d.c. supply circuit and overvoltage relay circuit of the control unit. The assembly is secured to a partition by four 4 B.A. cheese head screws; the lower pair mating with two 4 B.A. nuts, facing washers and spring washers and the top pair with two spacers, drilled and tapped 4 B.A. The partition is secured to the chassis base by two 6 B.A. cheese head screws and is supported at the top by a tie-bar. This is secured at one end to the partition by a 4 B.A. cheese head screw and at the other to the chassis upright by a 4 B.A. nut, facing washer and spring washer.

Resistor panel assembly

9. The resistor panel assembly comprises a paxolin panel on which is mounted the remainder of the resistors and one of the capacitors in the overvoltage relay circuit. The assembly is secured by four countersunk 4 B.A. screws locating in four spacers, two attached to the paxolin panel used in the rectifier panel assembly and two which are also used to secure the top of the rectifier panel assembly.

RESTRICTED

OPERATION

General

10. The control unit has a number of functions to perform, these fall under two main headings namely control and protection and are dealt with in the following paragraphs. The schematic wiring diagram fig. 5, shows the internal circuit of the

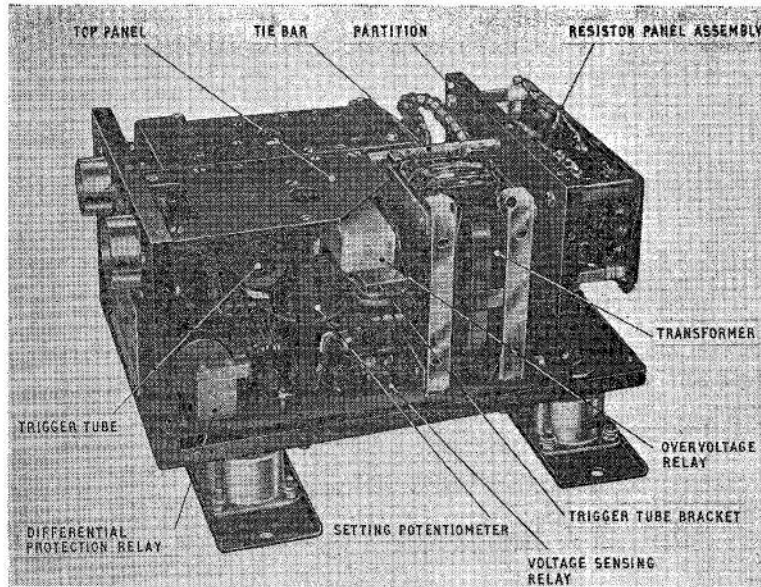

Fig. 2. General view, showing components

RESTRICTED

unit, and also the associated circuit diagram when used with the a.c. generator, Type 163. (E.E. Type AE2034).

Control

11. The components performing the function of control are as follows:-

- (1) Exciter control relay.
- (2) Lockout relay.

These are dealt with in detail in paragraphs 12 and 13.

Exciter control relay

12. This is a latched relay with 'trip' and 'set' coils. The 'set' coil operates a bank of 6 contacts and the 'trip' coil a single set of contacts; but for this application of the relay, the single set of contacts are not connected. The function of the single set of contacts is to de-energize the 'set' coils, this is now performed by the lockout relay. Under normal operating conditions, when the main control switch is closed to 'ON', the 'set' coil is energized, and a set of contacts will close to complete both the exciter field circuit and the lockout relay coil circuit. The lockout relay operates to de-energize the 'set' coil of the exciter control relay, but the contacts of the exciter control relay remain closed because of the latch mechanism. Thus the 'set' coil is only energised during the actual switching period. The 'trip' coil circuit of the exciter control relay is completed by the closing of the contacts of either the overvoltage relay or the differential protection relay, due to a fault condition. When the relay 'trips', the latch mechanism is released and the contacts

of the relay open, breaking the exciter field and 'trip' coil circuits. The relay will remain in this condition until the 'set' coil is once again energized. One of the bank of six contacts is connected in series with a set of contacts on the under-speed relay to complete the circuit to the main supply contactor.

Lockout relay

13. This relay prevents the exciter control relay from 'cycling' if an attempt is made to reset it while a fault condition still exists. Should the main control switch be set to 'RESET' during a fault condition, the exciter control relay will close and trip once, the 'set' coil circuit of the exciter control relay is then interrupted by open contacts of the energised lockout relay and thus cycling of the exciter control relay is prevented. The 'set' coil of the exciter control relay cannot be re-energised until the main control switch has been released.

Protection

14. The components used for protection of the system are as follows:-

- (1) Differential protection relays.
- (2) Underspeed relay.
- (3) Overvoltage relay.
- (4) Voltage sensing relay.

These are dealt with in more detail in paragraph 15 to 19 inclusive.

Differential protection relays

15. There are three of these relays, one

RESTRICTED

for each a.c. generator output line, providing protection against line to line and line to earth fault, conditions. Each relay is connected across the secondaries of two current transformers, which are located externally in each a.c. generator output line. A fault condition will cause an out-of-balance phase current to flow, current will then flow through the secondary of the appropriate transformer and so to the coil of a differential protection relay. The relay will operate and complete the 'trip' coil circuit of the exciter control relay.

Underspeed relay

16. This is a latched relay with 'trip' and 'set' coils and is similar to the exciter control relay, but in this application the single set of contacts are used for their normal function. When the 'set' coil is energised, the 'set' armature will close the bank of six contacts and operate the latch mechanism which opens the single set of contacts, breaking the 'set' coil circuit. One of the bank of six contacts completes the 'trip' coil circuit. When the 'trip' coil is energised the 'trip' armature operates the latch mechanism to open the bank of six contacts, breaking the 'trip' coil circuit and closing the single set of contacts to complete the 'set' coil circuit. Thus the coils are only energised for the actual switching period.

17. The relay is used to control the supply contactor. The operation of the relay is controlled by the underspeed switch on the a.c. generator, this completes the 'set' and 'trip' coil circuits of the relay. The relay through the action of the switch ensures that the a.c. generator cannot be connected to the bus-bars at speeds below the specified minimum.

Overvoltage relay

18. The overvoltage relay is connected in the overvoltage protection circuit which incorporates a cold cathode trigger tube, bridge rectifier, capacitors and resistors and a setting potentiometer. When the trigger tube 'ignites' and the maintaining voltage of the tube is reached, the overvoltage relay will operate. One pair of contacts of the relay closes to complete the 'trip' coil circuit of the exciter control relay, thus isolating the exciter field. A second pair of contacts close, to by-pass the tube to earth, so that it is cut-off immediately after operating the relay. Ignition of the tube is controlled by the voltage on the 'triggering' anode, this voltage is set by the potentiometer. Capacitors provide a time delay in the circuit. The circuit is designed to provide a time/voltage characteristic which ensures no nuisance operation of the overvoltage relay (therefore tripping of the exciter control relay) on surges arising in the bus-bar circuits.

Voltage sensing relay

19. The voltage sensing relay is used to connect 28 volts d.c. to the protection circuits, the normally closed contacts connecting the internal source. When an external 28 volt supply is connected, the relay operates to change over its contacts and supply the protection circuit from the external source.

Transformer and rectifiers

20. In addition to the components under the headings of 'Control' and 'Protection' there are two main components which make up the unit, namely the main transformer and rectifiers. The transformer provides, through the rectifier bridge, RECT. 2, the

RESTRICTED

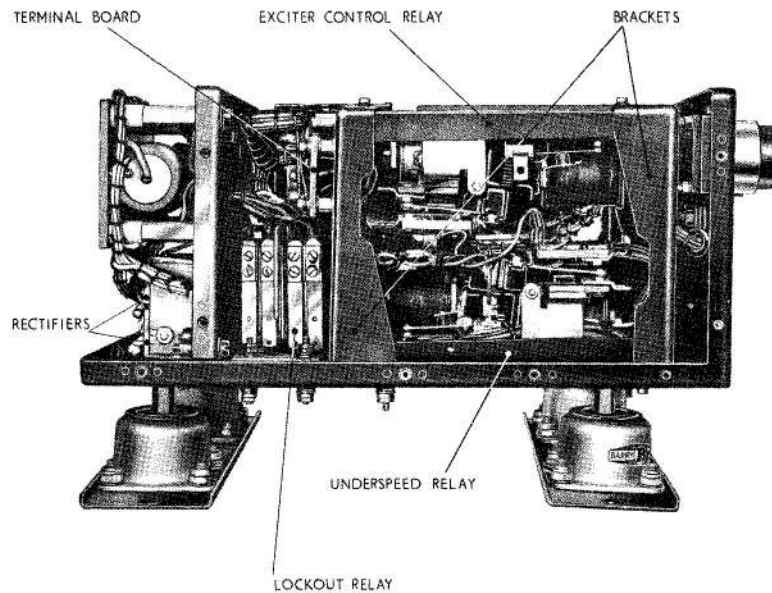

Fig.3 Side view, showing components

internal source of 28 volts, d.c., for operation of the protection circuits. The rectifier bridge, RECT. 1, provides the d.c. supply for the overvoltage protection circuit.

COOLING

21. The cover of the unit is provided with four mesh covered holes, these provide a natural means of cooling by allowing dissipation of heat from within the panel.

INSTALLATION

22. The unit must be mounted in a horizontal plane and secured by four bolts, through the four holes provided in the channel support brackets.

SERVICING

23. On receipt of a new or reconditioned control unit and prior to installation in the aircraft, the unit should be inspected

for corrosion and damage to the case, all components, electrical connections and anti-vibration mountings. It is essential that the timing and voltage settings of the operation of components fitted to the unit be within satisfactory limits. Therefore, replacement of defective components and the necessary testing and adjustments should only be completed by servicing units suitable equipped to do so, otherwise the complete unit should be returned to the manufacturer for overhaul and testing.

TESTING

General

24. If for any reason it is suspected that the unit or any of its components are not operating correctly, the following checks and tests should be completed to ensure the serviceability of the unit.

RESTRICTED

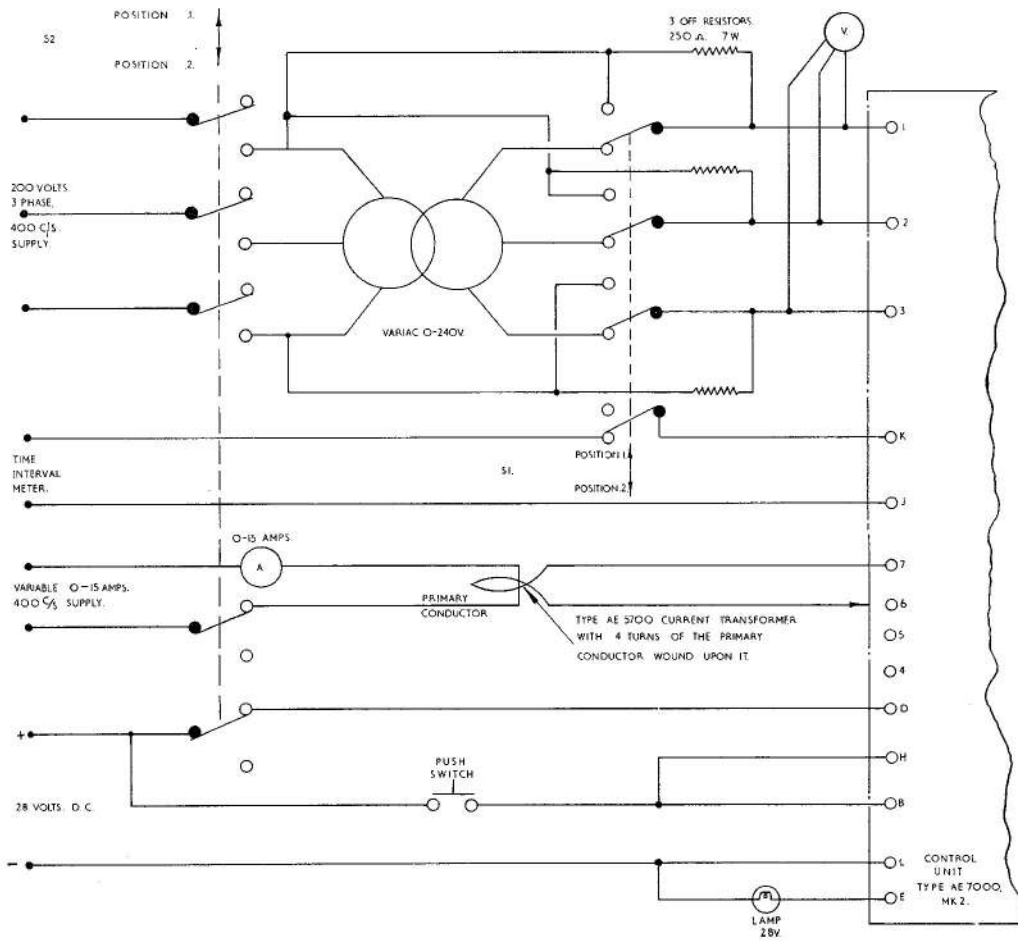

Fig.4 Test circuit diagram

Note . . .

1. Two plugs on unit.
(Pins on one, numbered.
Pins on other, lettered.
2. Time interval meter measures the
time pins J and K are short circuited.
3. Voltmeter V reads mean R.M.S. voltage
between three lines.
4. S1. is a four-pole ganged switch.
5. S2. is a five-pole ganged switch.

RESTRICTED

25. It will be necessary to remove the cover for access to certain components during testing of the unit.

Relay resistance test

26. The resistance of the lockout relay coil and exciter control relay 'set' coil connected in series should be checked as follows:-

- (i) Ensure the exciter control relay is in the tripped position.
- (ii) Connect an ohmmeter to turret lugs B and M, on the relay and bracket assembly terminal board.
- (iii) Check that ohmmeter reads 70 ohms, plus or minus 10 ohms.
- (iv) Disconnect ohmmeter.

Test circuit

27. Connect the unit as shown in the test circuit diagram fig.4. The a.c. voltmeter used is to be accurate to within plus or minus 0.5 per cent and have a scale of 0 - 250 volts.

Transformer/Rectifier check

28. Apply a 3-phase, 400 c/s, 200 volt, supply to pins 1, 2 and 3 on the control unit by setting switch S1 to position 1 and switch S2 to position 2. Check, using a suitable meter, that a d.c. voltage of 28 volts, plus or minus 3 volts, is available across pins D and L (L-negative). Set switch S2 to position 1.

Overvoltage circuit check

29. Ensure switch S2 is set to position 1. Momentarily depress the push switch

and ensure the exciter control relay and the underspeed relay operate to their respective 'set' positions and the 28 volt lamp is illuminated. Ensure when the push switch is released that both relays remain set and 28 volt lamp therefore remains illuminated. Apply a variable a.c. supply to pins 1, 2 and 3 on the control unit by setting switch S1 to position 2 and switch S2 to position 2. Ensure 28 volt lamp is illuminated. Operate the variac to increase the voltage to the panel. Check, using the voltmeter (V), that the overvoltage relay operates at 218 volts, the exciter control relay trips and the trigger tube and 28 volt lamp are both extinguished. Set switch S1 to position 1. Set switch S1 to position 2 and using the time level meter ensure that the trigger tube does not ignite within 60 seconds. Set switch S2 to position 1.

Note . . .

The exciter control relay must be re-set before the overvoltage relay will operate once more.

Differential protection relay checks

30. Ensure switch S2 is set to position 1. Momentarily depress the push switch and ensure the exciter control relay 'sets' and the 28 volt lamp is illuminated. Connect the wandering lead from the current transformer to pin 4 on the control unit. Increase the current through the primary conductor until the differential relay operates to 'trip' the exciter control relay; at this moment check that the 28 volt lamp is extinguished and the ammeter (A) reading is 9.5 amps., plus or minus 1.0 amp. Reduce the current to zero. Reset the exciter control relay by momentarily depressing the push and ensure the 28 volt

RESTRICTED

lamp is illuminated. Repeat the test for the remaining two differential relays, connecting the wandering lead to pins 5 and 6 in turn. Finally reset the exciter relay by momentarily depressing the push switch.

Wiring and d.c. relay checks

31. These checks are shown in 'table 1' at the end of this chapter. The following are required to enable the checks to be completed:-

- (1) A variable d.c. voltage from zero to 28 volts.

- (2) A universal testmeter required to read 0-30 volts and 0-1000 ohms.
- (3) An ammeter required to read milliamps (100 mA) and amperes (1 amp). This meter is to be connected to indicate the current drawn from the supply.

Insulation test

32. The insulation resistance should be measured between the pins on the unit and the frame, using a 500 volt d.c. insulation resistance tester. The minimum permissible reading is 20 megohms.

RESTRICTED

TABLE 1. WIRING AND D.C. RELAY CHECKS.

No.	Apply Variable 28 Volts to Pins:-		Universal Testmeter Connected to Pins:-		Voltage or Resistance Reading		Approx. Current - Ammeter Reading		Details
	+ ve	- ve	+ ve	- ve	Before operation of relay	After operation of relay	Transt.	Steady	
1	*B	L	J	K	OC	SC	10mA	0.4 A	E.C.R. sets and latches. L.O.R. operates (E.C.R. sets at less than 12 volts)
2	*C	L	J	K	SC	OC			
3	No Volts		B	A	OC				
4	B	L	A	B	470 ohms (approx)	OC	0.9A	0.9A	Rectifier check Resistance and blocking rectifier check. E.C.R. sets and latches. L.O.R. operates.
5	**B	L	E	D	SC	OC			
6	C	L	E	D	OC	SC			
7	B	L	E	D	OC	SC	8mA	0.9A	E.C.R. sets and latches.
8	*G	L	E	D	SC	OC			
9	*H	L	E	D	OC	SC	30mA	0.3A	U.S.R. trips at less than 12 volts.
10	*B	L	J	B	470 ohms (approx)	OC			
11	*F	L	D	E	SC	OC	35mA	35mA	L.O.R. operates at less than 8 volts. V.S.R. operates at less than 20 volts.
12	F	L	A	J	SC	OC			
	F	L	D	L	OC	28 volts			

LEGEND.

1. OC - Open circuit.
2. SC - Short circuit.
3. Ensure checks are carried out in numbered sequence 1 - 12.
4. * - Indicates voltage should be increased slowly from zero and minimum operating voltage of relay noted.
5. 28 V to be applied except where otherwise indicated.
6. Testmeter scale should be selected to volts or ohms for appropriate check.
7. ** - Apply voltage to B before C to set E.C.R.
8. Ensure U.S.R. is set before carrying out checks 5, 6 and 7.

RESTRICTED

Fig 5 SCHEMATIC WIRING DIAGRAM
RESTRICTED

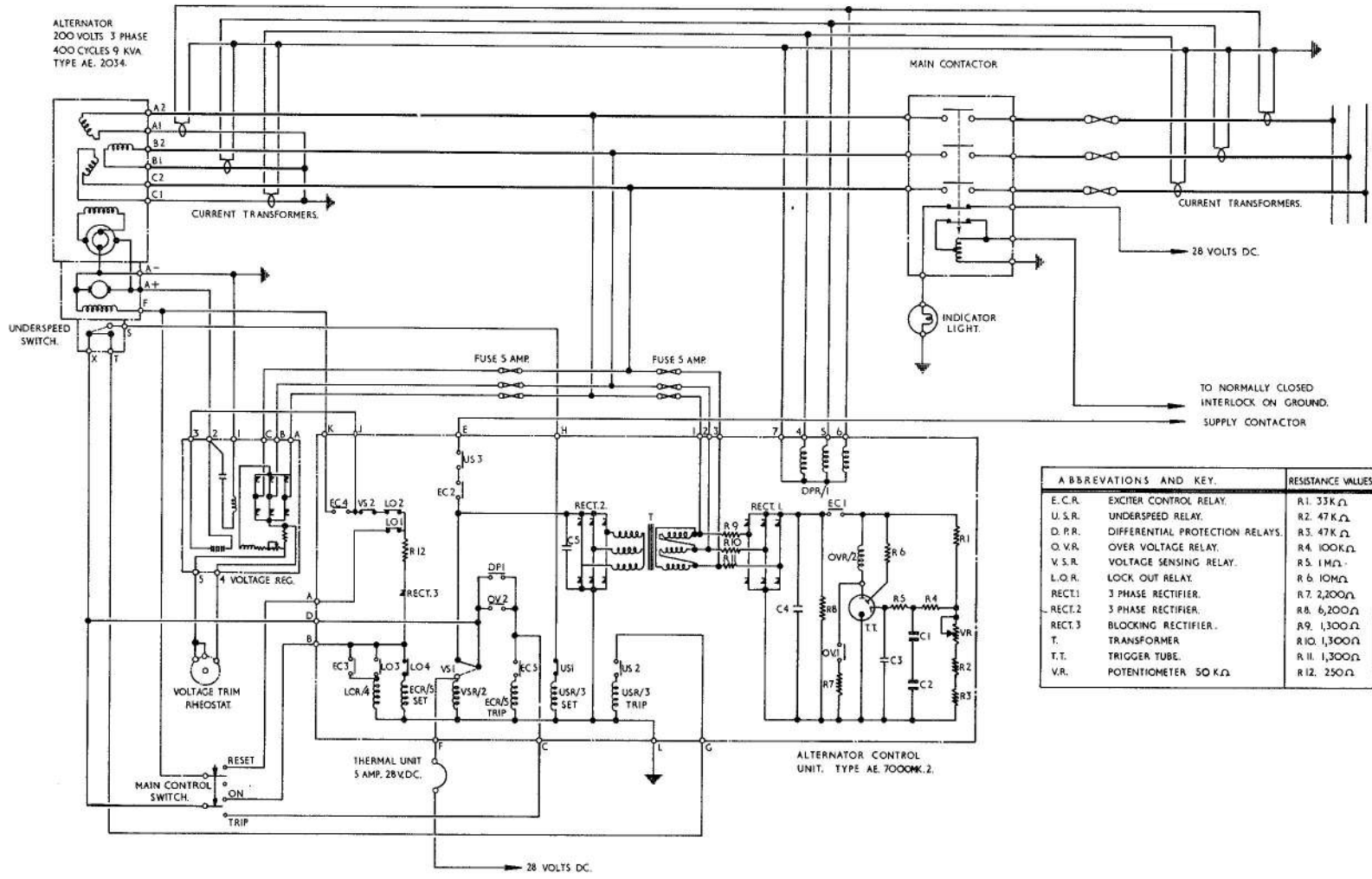

ABBREVIATIONS AND KEY		RESISTANCE VALUES	CAPACITANCE VALUES
E.C.R.	EXCITER CONTROL RELAY.	R1. 33K Ω .	C1 50 μ f
U.S.R.	UNDERSPEED RELAY.	R2. 47K Ω .	C2 5 μ f
D.P.R.	DIFFERENTIAL PROTECTION RELAYS.	R3. 47K Ω .	C3 0.002 μ f
O.V.R.	OVER VOLTAGE RELAY.	R4. 100K Ω .	C4 0.5 μ f
V.S.R.	VOLTAGE SENSING RELAY.	R5. 1M Ω .	C5 0.01 μ f
L.O.R.	LOCK OUT RELAY.	R6 10M Ω .	
RECT.1	3 PHASE RECTIFIER.	R7. 2,200 Ω .	
RECT.2	3 PHASE RECTIFIER.	R8. 6,200 Ω .	
RECT.3	BLOCKING RECTIFIER.	R9. 1,300 Ω .	
T.	TRANSFORMER.	R10. 1,300 Ω .	
T.T.	TRIGGER TUBE.	R11. 1,300 Ω .	
V.R.	POTENTIOMETER 50 K Ω .	R12. 250 Ω .	

This file was downloaded
from the RTFM Library.

Link: www.scottbouch.com/rtfm

Please see site for usage terms,
and more aircraft documents.

