

Chapter 19

VOLTAGE CONTROL UNIT, ROTAX, TYPE U3703

LIST OF CONTENTS

	Para.		Para.
<i>Introduction</i>	1	<i>Error sensing circuit</i>	12
Description	2	Installation	17
<i>Operation</i>	5	Servicing	19
<i>Voltage control system</i>	10	<i>Insulation resistance tests</i>	20

LIST OF TABLES

	Table
<i>Circuit component details</i>	1

LIST OF ILLUSTRATIONS

	Fig.		Fig.
<i>General view</i>	1	<i>Layout of components (3)</i>	4
<i>Layout of components (1)</i>	2	<i>Circuit diagram</i>	5
<i>Layout of components (2)</i>	3		

LIST OF APPENDICES

	App.
<i>Voltage control unit, Rotax, Type U3703/1</i>	1

LEADING PARTICULARS

Voltage control unit, Type U3703	Ref. No. 5UC/6530
<i>Output voltage</i>	185V a.c. (R.M.S.) ± 5 per cent
<i>Phases</i>	3
<i>Frequency</i>	370 c/s ± 5 per cent
<i>Load range</i>	0-15 kVA
<i>Power factor</i>	0.5 to 0.8 lagging
<i>Temperature range</i>	-40 deg C. to +30 deg. C
<i>Altitude range</i>	25,000 to 60,000 ft.
<i>Rating</i>	continuous
<i>Cooling</i>	natural
Overall dimensions—	
<i>Length (over handle)</i>	11.750 in. (max.)
<i>Width</i>	9.250 in. (max.)
<i>Height</i>	9.000 in. (max.)
<i>Weight</i>	19 lb.

RESTRICTED

Introduction

1. The Type U3703 voltage control unit (*fig. 1*) is designed to control the 15 kVA emergency supply provided by a self-excited ram air turbine alternator. Details of the U3703/1, a version modified to obviate collapse of generation under adverse load transfer conditions, will be found in Appendix 1.

DESCRIPTION

2. The components are housed within a metal box, the cover having perforated panels for ventilation.

3. Two chassis, one fixed and the other hinged, are used for mounting the components; by turning the hinged chassis about the hinge pin, access is gained to all component parts. The components are identified by code symbols which are directly related to the circuit diagram (*fig. 5*).

4. *Fig. 2, 3 and 4* show the physical layout of the components in the unit.

Operation

5. Control of the bus bar voltage is obtained

by a system of operation which is based on the use of a magnetic amplifier for closed loop voltage control. The average of the three line voltages is controlled at 185-volts R.M.S. ± 5 per cent from no load to 15 kVA, power factor 0.5 to 0.8 lagging, with the speed mechanically governed to 7,400 r.p.m.

6. A facility to minimize the effect of overload on the turbine is achieved by modifying the voltage controlled level proportional to change in frequency. Excessive loading will cause the turbine to slow down, and the efficiency will drop, therefore a stall condition could occur. Any tendency towards overloading of the control motors will result in the turbine speed falling; to limit the controlled voltage level on turbine overspeed a zener diode 1MR8 is introduced. The regulator will then effect a reduction in the controlled voltage level, which relieves the system of electrical power loading until the overload is removed.

7. The regulator circuit is modified for speeds in excess of normal so that a pre-determined maximum controlled voltage level is effected.

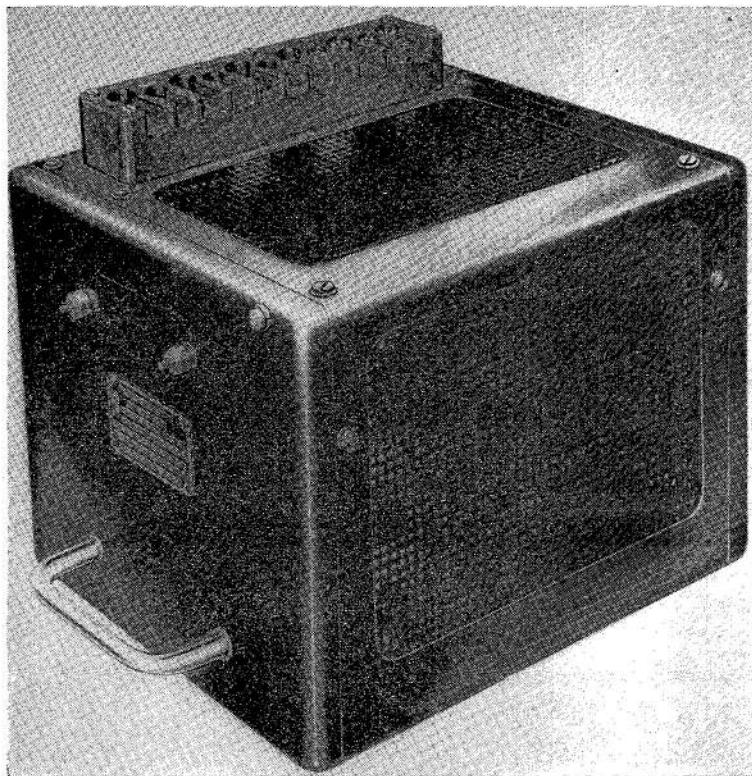

Fig. 1. General view

RESTRICTED

8. The selection of 185-volts, 370 c/s as the nominal controlled level is to minimize peak loading on the emergency system. On failure and subsequent rundown of the main generating system, automatic transfer to the emergency supply occurs at approximately 185-volts, 370 c/s, and so any tendency to accelerate flying control motors which form the major parts of the emergency loading is minimized.

9. Minor adjustments of the controlled voltage level can be made with the voltage trimmer potentiometer (IRV5) which is located behind the swing cover plate on the

front of the unit above the data plate adjustments can be made in steps of approximately 1V to $\pm 9V$ without the necessity of disturbing the unit cover (fig. 4).

Voltage control system

10. Components of the regulator include:—

- (1) An error sensitive network, comprising two circuits, one containing resistors IR7 and IR8, and the other barretter 1L1.
- (2) An error magnetic amplifier containing a pre-amp. transducer 1TD2, and a pre-amp. rectifier 1MR5.

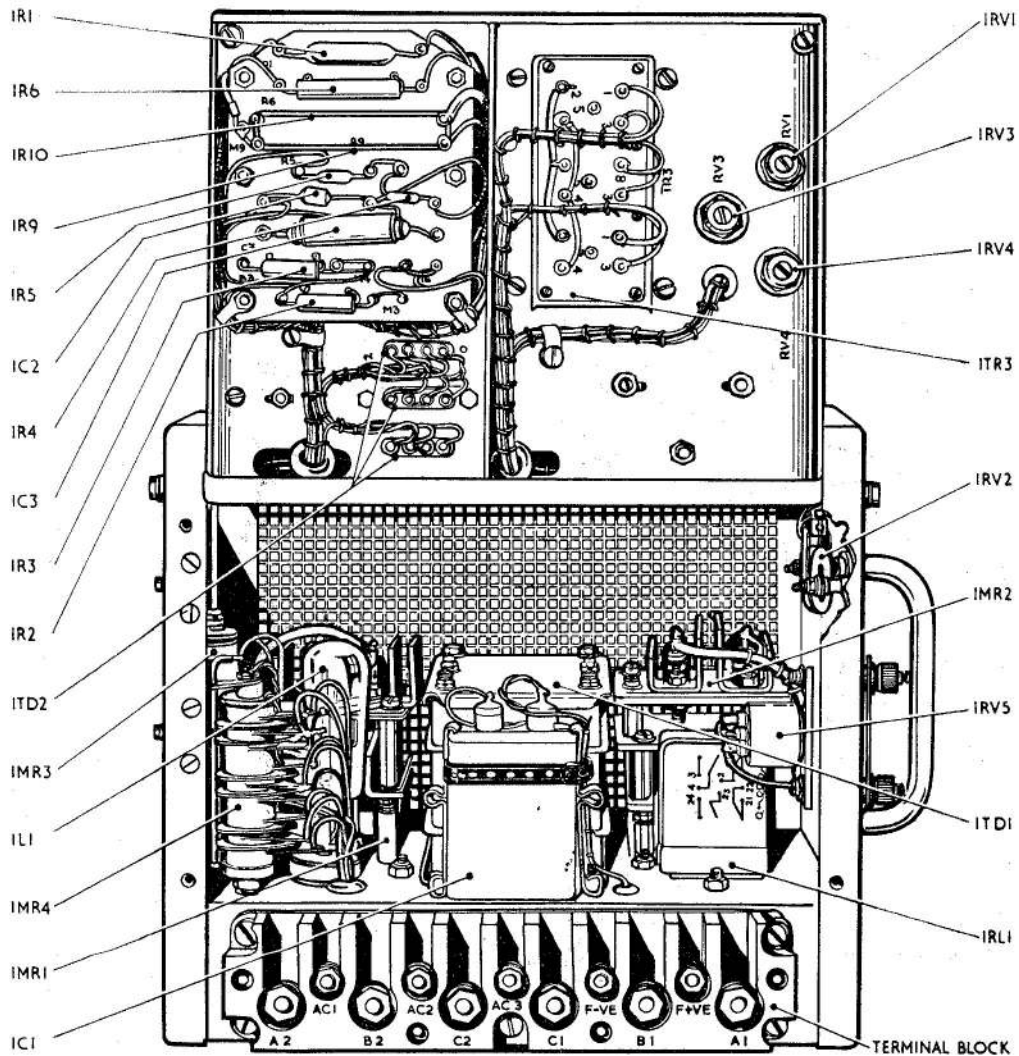

Fig. 2. Layout of components (1)

RESTRICTED

(3) A power magnetic amplifier comprising excitation transductor 1TD1, and main auto rectifier 1MR4.

11. The total excitation requirement of the alternators is provided by the combination of the amplifier error and power magnetic signals which in turn combine with the current compounding output of 1TRI.

Error sensing circuit

12. Sensing of the error between the desired line voltage and actual line voltage is dependent upon the comparison of the two resistive circuits. One circuit containing 1R7 and 1R8 provides a linear voltage current relationship, and the other containing barretter 1L1 gives an almost constant current

The two signal currents are then fed in opposing senses to the control windings of the error amplifier 1TD2.

13. The total resistance of 1R7 and 1R8 is such that at the required bus-bar voltage its current is nominally equal to the current in the barretter circuit. In practice a slight unbalance of currents at the desired voltage level obviates the use of a bias winding on transductor 1TD2. Any change in the average of the three R.M.S. line voltages above or below the nominal level is detected by the voltage sensitive network. The error signal is then fed into the error amplifier 1TD2, the output of which is in turn fed as a negative control into the power magnetic amplifier (1TD1, 1MR4). The resultant

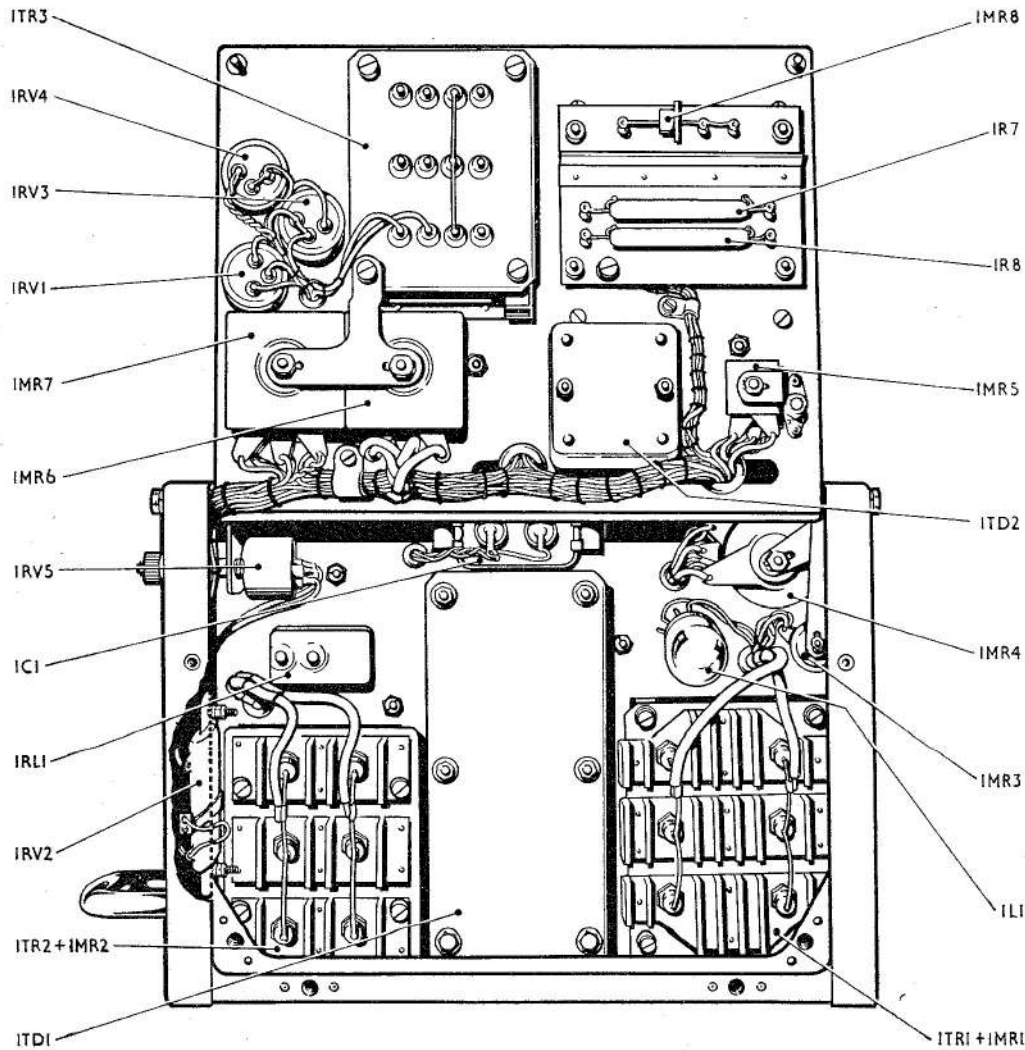

Fig. 3. Layout of components (2)

RESTRICTED

output from 1TD1 and 1MR4 is supplied to the alternator field as the modified excitation contribution of the regulator, thereby correcting the voltage error.

14. Error sensing is made frequency dependent with the introduction of a signal derived from a permanent magnet a.c. generator built as an integral part of the main alternator. This signal is suitably rectified at 1MR6 and fed via resistors 1R5, 1R6, 1RV4, 1RV5. The purpose of the error magnetic amplifier 1TD2 and 1MR5 is to relieve the duty of the power magnetic amplifier. This improves stability with the

temperature variation and reduces the overall time constant of the regulator.

15. The error amplifier output is fed as a negative control to the power magnetic amplifier, thereby determining the output delivered from this source. A positive bias signal is applied to the power transductor to compensate for the standing output of the error amplifier. The power amplifier comprises a six element three-phase transductor 1TD1, and rectifier 1MR4, arranged to give a magnetic amplifier of auto-self-excited configuration. The transformer 1TR2 matches the transductor output to the excitation

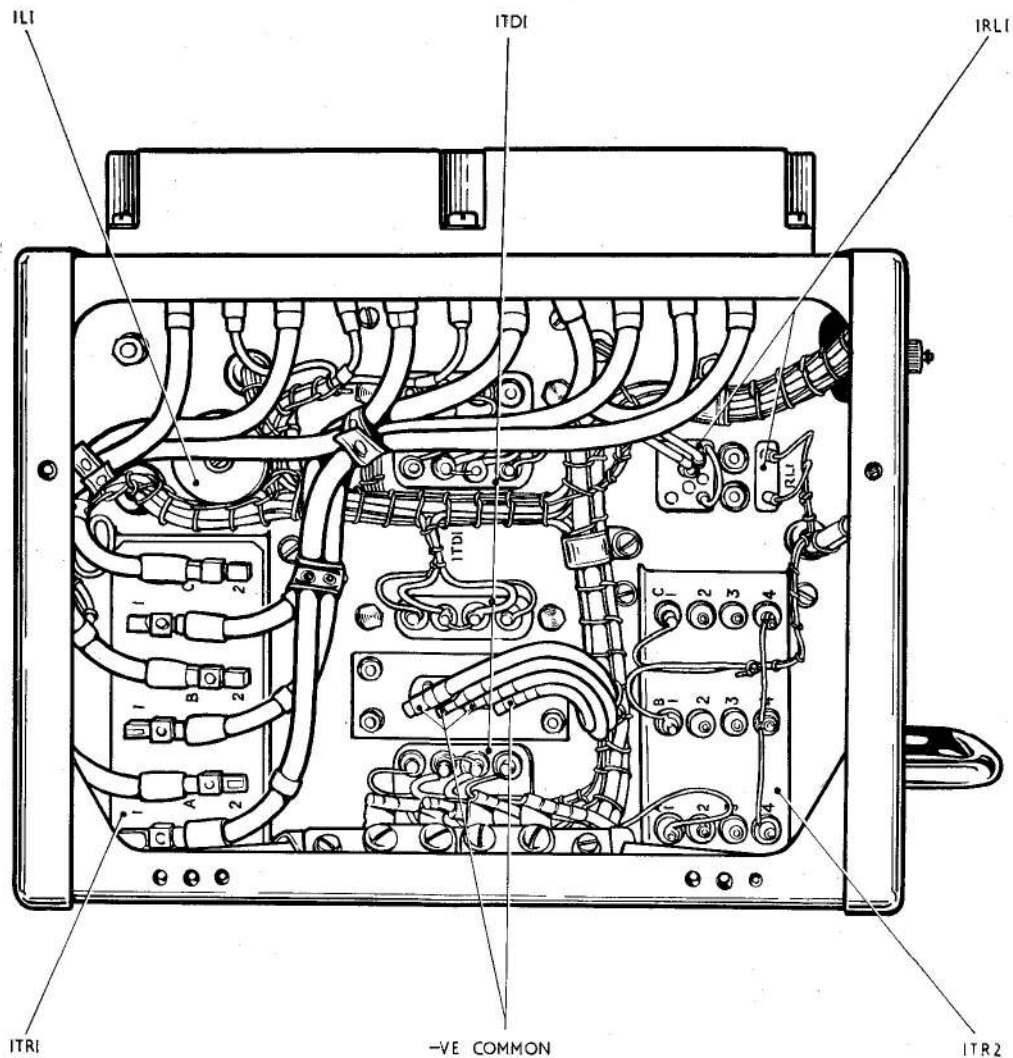

Fig. 4. Layout of components (3)

RESTRICTED

circuit, with silicon rectifier 1MR2 providing three-phase bridge rectification.

16. Stabilization of the closed loop voltage regulating system is provided by transient negative feed back networks passed over each amplifier stage. A signal proportional to the output current of the error amplifier is derived across coupling resistor 1RV3 and is fed over transducer 1TD2 via the network 1C3 and 1R3. At the output stage a three-phase voltage proportional to the field voltage is rectified by 1MR3 and fed over transducer 1TD1 via capacitor 1C1.

INSTALLATION

17. The unit must be mounted base downwards and secured by four 0.250 in. B.S.F. stiff anchor nuts, located in the base of the unit.

18. Electrical connections are made via an 11 point terminal block mounted on top of the unit. The terminal block is marked accordingly. A2, B2, C2, C1, B1, and A1, for the six 0.250 in. B.S.F. terminal studs, and AC1, AC2, AC3, F-VE and F+VE for the five 2 B.A. terminal studs respectively. Remove the terminal block cover by releasing the four captive screws to expose the above engraving details.

SERVICING

19. Servicing of these units will normally be restricted to checking security of connections and that no damage is apparent. Where it is obvious that such components as transformer rectifiers, etc. are unserviceable, these components will need renewal. A list of components is given in Table 1.

Insulation resistance tests

20. (a) Common together terminals A1, B1, C1, and by means of flying leads and crocodile clips, connections A1 and A2, on transducer 1TD1, and bring out the connection as a common lead. Common together terminals AC1, AC2, AC3, F+VE, F-VE, and by means of flying leads and crocodile clips connections A4, B4, C4 and C9-C10 on transformer 1TR3, and bring out the connection as a common lead.

(b) Connect all but the first commoning lead to a suitable point on the chassis, and check the insulation resistance; this should not be less than 5 megohms, using a 250-volt insulation tester.

(c) Repeat the insulation resistance test between chassis and each of the remaining commoning leads in turn, with the other two commoning leads connected to the chassis. In each case the insulation resistance must not be less than 5 megohms.

RESTRICTED

Table 1
Circuit component details

Cir. Ref.	Description	Value	Rotax No.
1TR1	Compounding transformer (1TR1 + 1MR1 assembly)		P7302
1TR2	Excitation transformer (1TR2 + 1MR2 assembly)		P7404
1TR3	Supply and reference transformer		P7501
1TD1	Excitation transducer		P7102
1TD2	Pre-amp. transducer		P7201
1RL1	Isolating relay		
1L1	Barretter		
1MR1	Compounding rectifier		see 1TR1
1MR2	Excitation rectifier		see 1TR2
1MR3	Feed-back rectifier		
1MR4	Main auto. rectifier		
1MR5	Pre-amp. rectifier		
1MR6	Exciter supply rectifier		
1MR7	Signal rectifier		
1MR8	Voltage limiting rectifier		
2ALT1	A.C. generator	15kVA	BA1601 or BA1602
1RV1	Output bias control potentiometer	350 ohms, 1W	
1RV2	Relay operating control variable resistor	680 ohms	
1RV3	Coupling control potentiometer	500 ohms, 1W	
1RV4	Voltage/frequency limiting control potentiometer	10 ohms, 1W	
1RV5	Signal control potentiometer	5 ohms, 1W	
1R1	Feedback load resistor	10K ohms, 4½W	
1R2	Bias resistor	620 ohms, 3W	
1R3	Current feedback resistor	1.5 ohms, 3W	
1R4	Gain limiting resistor	390 ohms, 1½ W	
1R5	Voltage/frequency trim resistor	2.2 ohms, 1½W	
1R6	Voltage/frequency resistor	20 ohms, 4½W	
1R7	Signal resistor	22 ohms, 6W	
1R8	Signal resistor	22 ohms, 6W	
1R9	22 S.W.G. tinned copper wire	—	
1R10	22 S.W.G. tinned copper wire	—	
1C1	Feedback capacitor	15 µF, 150V	
1C2	Output transducer winding capacitor	10 µF, 30V	
1C3	Current feedback capacitor	40 µF, 12V	

RESTRICTED

C

9

5

C

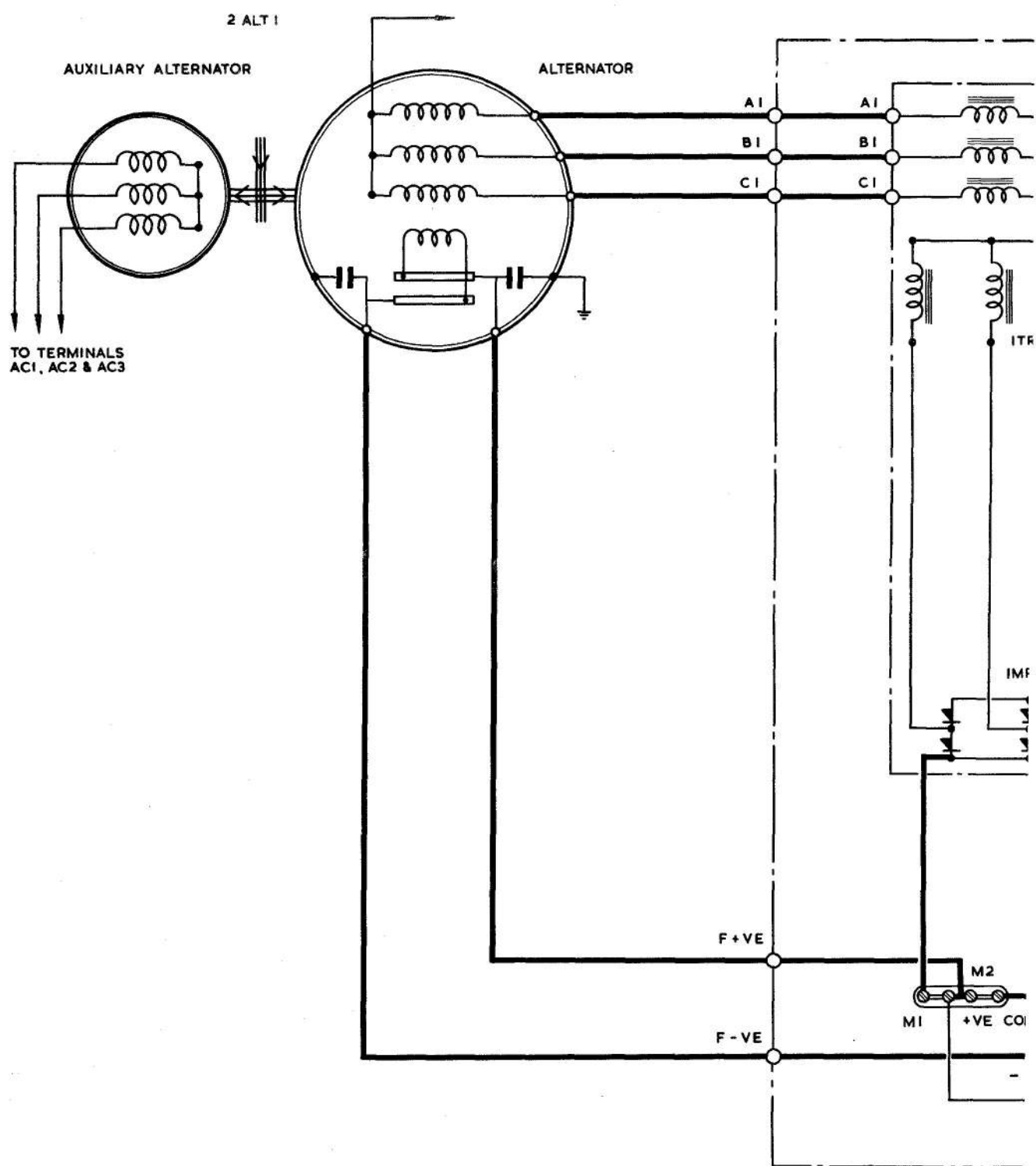
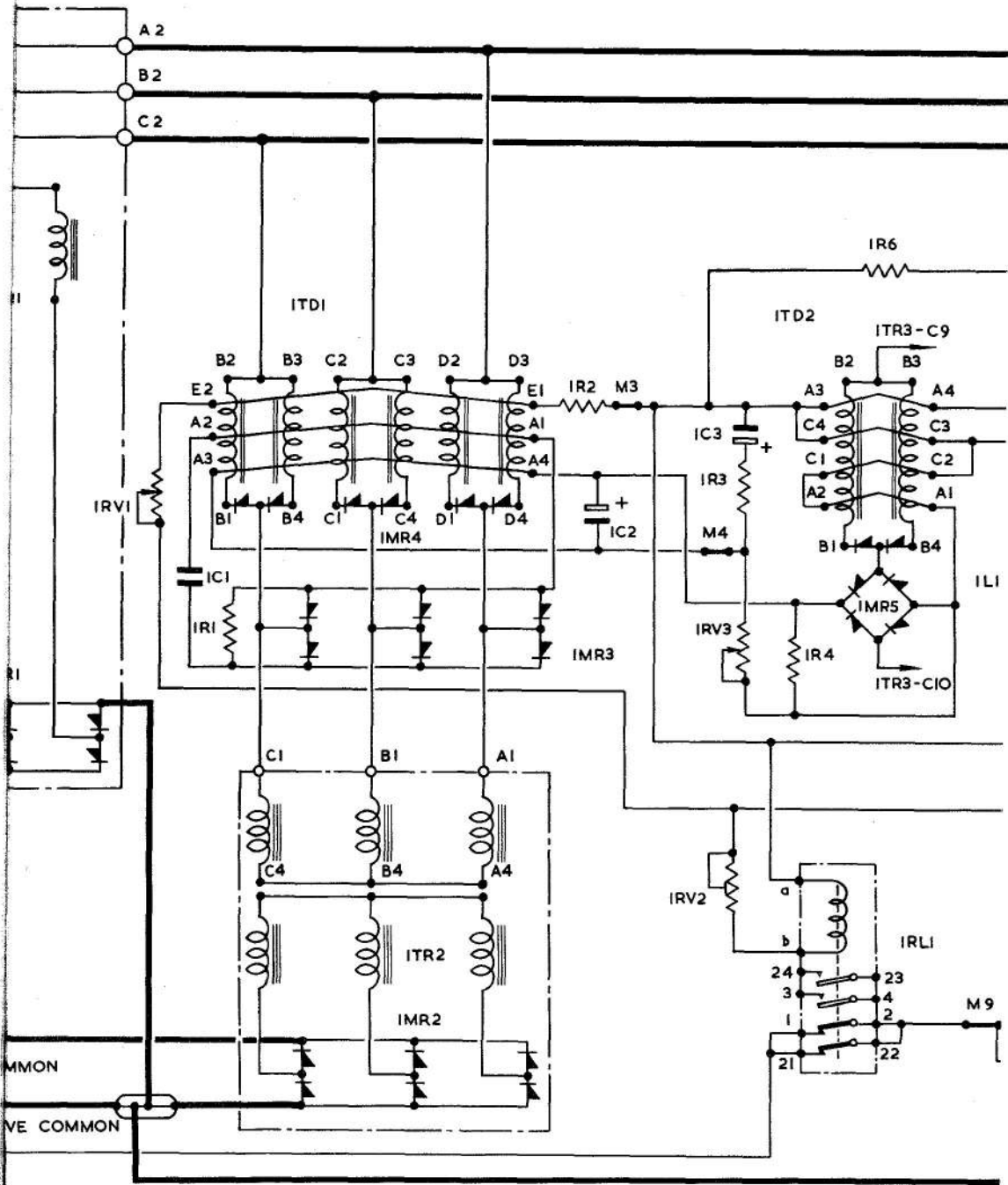
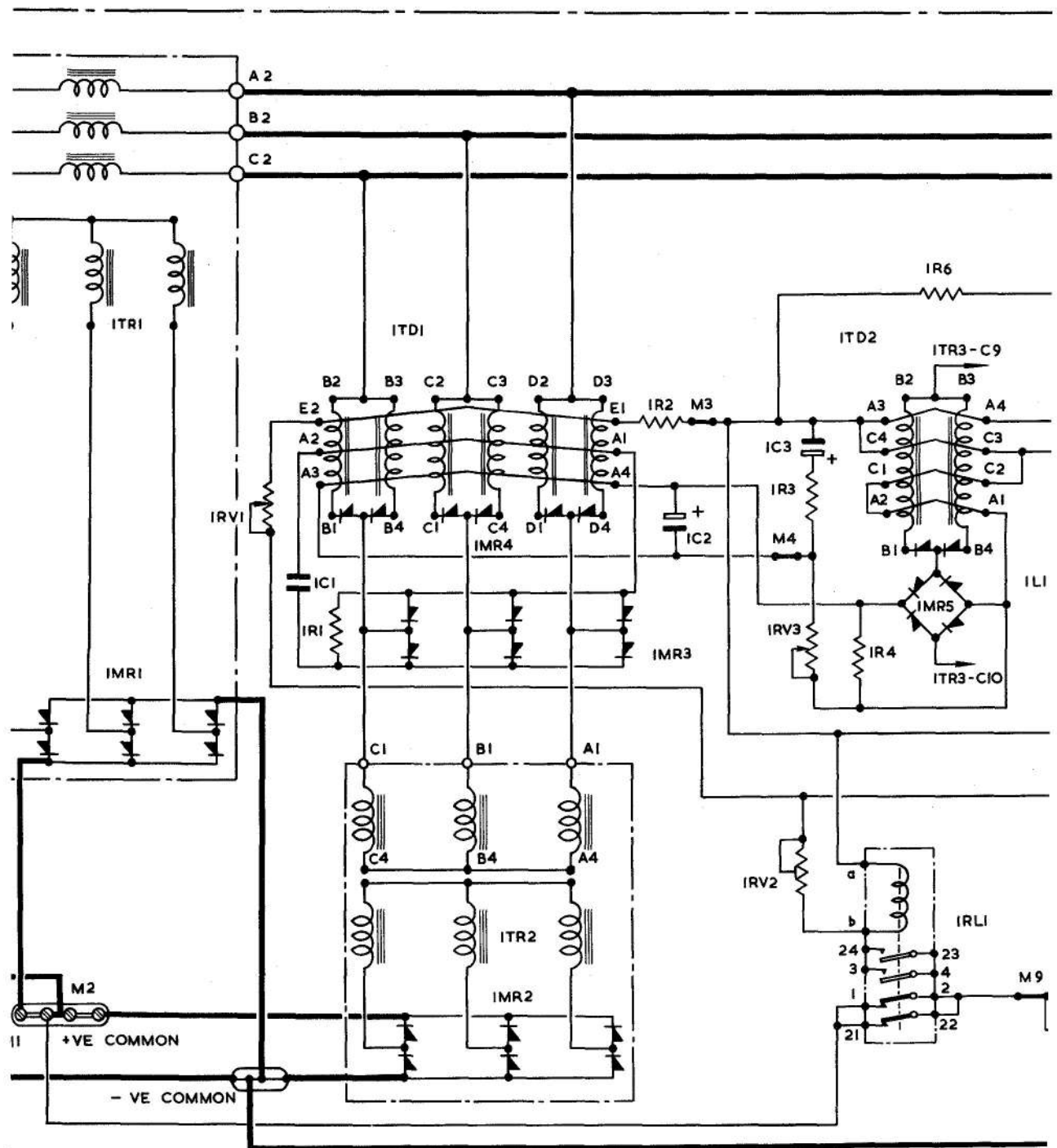

Fig. 5



Circuit diagram
RESTRICTED



Circuit diagram
RESTRICTED

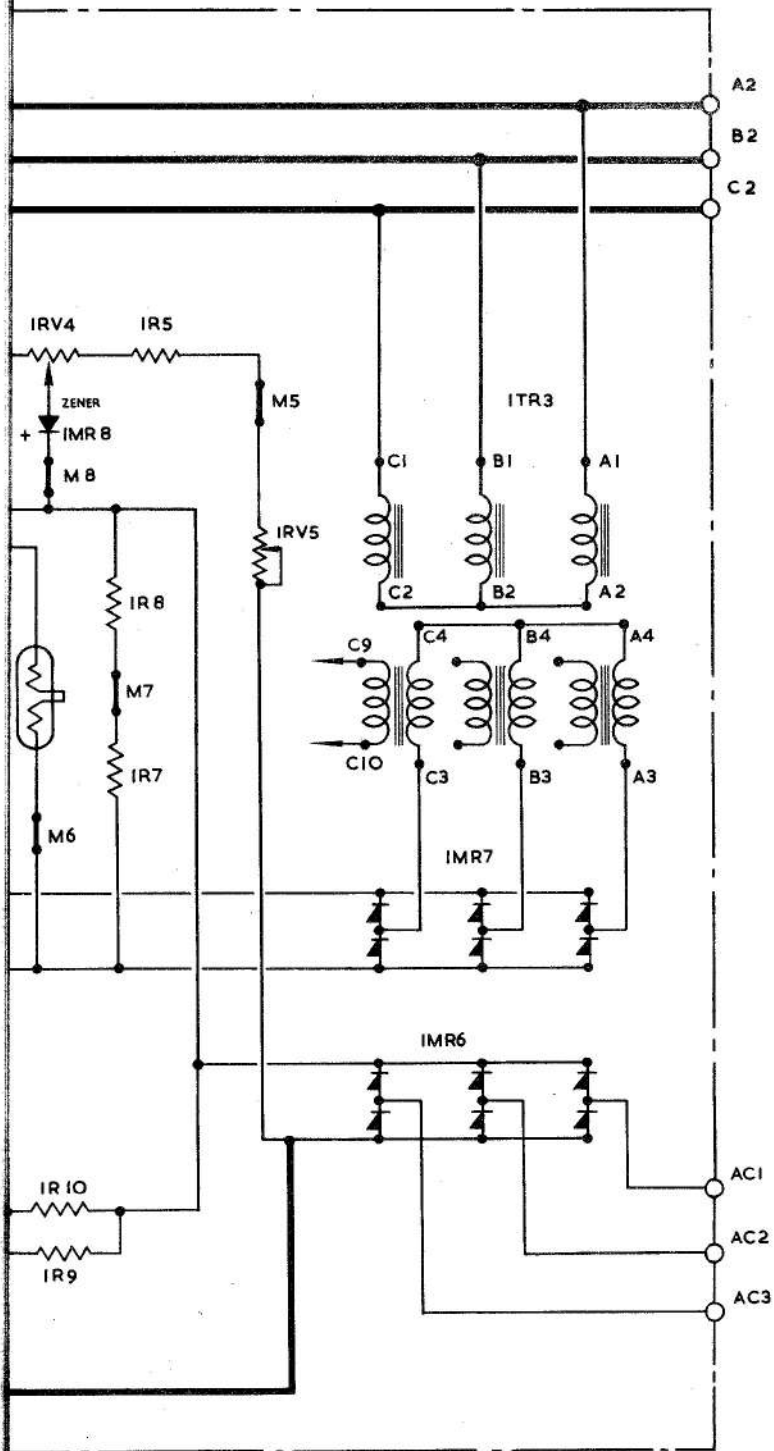

Fig. 5

Appendix 1

VOLTAGE CONTROL UNIT, ROTAX, TYPE U3703/1

LEADING PARTICULARS

Voltage control unit, Type U3703/1	Ref. No. 5UC/7227
<i>Output voltage</i>	185V a.c. (RMS) ± 5 per cent
<i>Phases...</i>	3
<i>Frequency</i>	370 c/s ± 5 per cent
<i>Load range</i>	0-15 kVA
<i>Power factor</i>	0.5 to 0.8 lagging
<i>Temperature range</i>	-40 deg. C to +30 deg. C
<i>Altitude range</i>	25,000 to 60,000 ft.
<i>Rating...</i>	Continuous
<i>Cooling</i>	Natural
<i>Overall dimensions—</i>							
<i>Length (over handle)</i>	11.750 in. (max.)
<i>Width</i>	9.250 in. (max.)
<i>Height</i>	9.000 in. (max.)
<i>Weight</i>	19 lb.

1. The voltage control unit, Type U3703/1, is identical to the Type U3703 described and illustrated in the main chapter, except that Mod. Elec. B496 (Rotax SP6142) has been embodied. This modification, classified B/2, introduces certain alterations designed to obviate collapse of generation under adverse load transfer conditions, i.e., on change-over from the main generating system to the emergency supply of the ram air turbine generators, and the code of the unit is thereby raised to /1.

2. The details of the alterations are as follows:—

- (1) ITR1 Compounding transformer P7302 replaced by P7303. Ratio of transformer windings altered.
- (2) IR2 Bias resistor, ohmic value altered from 620 ohms to 390 ohms.
- (3) IR5 Voltage/frequency trim resistor selected on test, 2.2 ohms or 4.7 ohms as applicable.

RESTRICTED

1

2

3

4

This file was downloaded
from the RTFM Library.

Link: www.scottbouch.com/rtfm

Please see site for usage terms,
and more aircraft documents.

