

**Chapter 2**  
**CONTROL PANEL, TYPE 4**

**LIST OF CONTENTS**

	<i>Para.</i>		<i>Para.</i>
<i>Introduction</i> ... ..	1	<b>Installation</b> ... ..	6
<b>Description</b> ... ..	2	<b>Servicing</b> ... ..	7

**LIST OF ILLUSTRATIONS**

	<i>Fig.</i>		<i>Fig.</i>
<i>Control panel, Type 4</i> ... ..	1	<i>Circuit diagram</i> ... ..	2

**LEADING PARTICULARS**

<b>Control panel, Type 4</b> ... ..	<i>Ref. No. 5UC/199</i>
<i>Voltage</i> ... ..	<i>12 or 28 V d.c.</i>
<i>Incorporating—</i>	
<i>Voltage regulator, Type E2</i> ... ..	<i>Ref. No. 5UC/410</i>
<i>Suppressor, Type B</i> ... ..	<i>Ref. No. 5CY/870</i>
<i>Fuse box, Type E</i> ... ..	<i>Ref. No. 5CZ/882</i>
<i>Fuse, Type S (10 amp.)</i> ... ..	<i>Ref. No. 5CZ/881</i>
<i>Capacitor</i> ... ..	<i>Ref. No. 10C/9116215</i>
<i>Capacitor, Type 2382</i> ... ..	<i>Ref. No. 10C/4572</i>
<i>Capacitor, 8 μF...</i> ... ..	<i>Ref. No. 5U/1555</i>
<i>Resistance, Type 143</i> ... ..	<i>Ref. No. 10W/8394</i>
<i>Resistance, Type 1932</i> ... ..	<i>Ref. No. 10W/1932</i>
<i>Resistance</i> ... ..	<i>Ref. No. 10W/9222135</i>
<i>Plugs—</i>	
<i>Type W199 (6-way)</i> ... ..	<i>Ref. No. 10H/392</i>
<i>Type W200 (6-way)</i> ... ..	<i>Ref. No. 10H/393</i>
<i>Type W204 (2-way)</i> ... ..	<i>Ref. No. 10H/397</i>

**RESTRICTED**

### Introduction

1. The control panel, Type 4, is used to control the voltage output of the a.c. generators, Types R and S, at 80 volts a.c. It serves the same purpose as the Type 3A, but has provision for remote operation. It incorporates the items of equipment listed under Leading Particulars, and is provided with various inter-connections to a number of plugs in the panel, thus forming a distribution box for both the a.c. and d.c. supplies to the radio equipment.

set by adjustment to the links, according to the type of generator in use, in the manner indicated on the diagram. Voltage regulation of the generator is effected by a voltage regulator, Type E.2.

4. The battery supply passes through a suppressor, Type B, the contacts of the relay  $Rel_2$  and the carbon pile resistance to the field of the a.c. generator. The contacts of the relay  $Rel_2$  are closed by means of a remote switch which is connected between the posi-

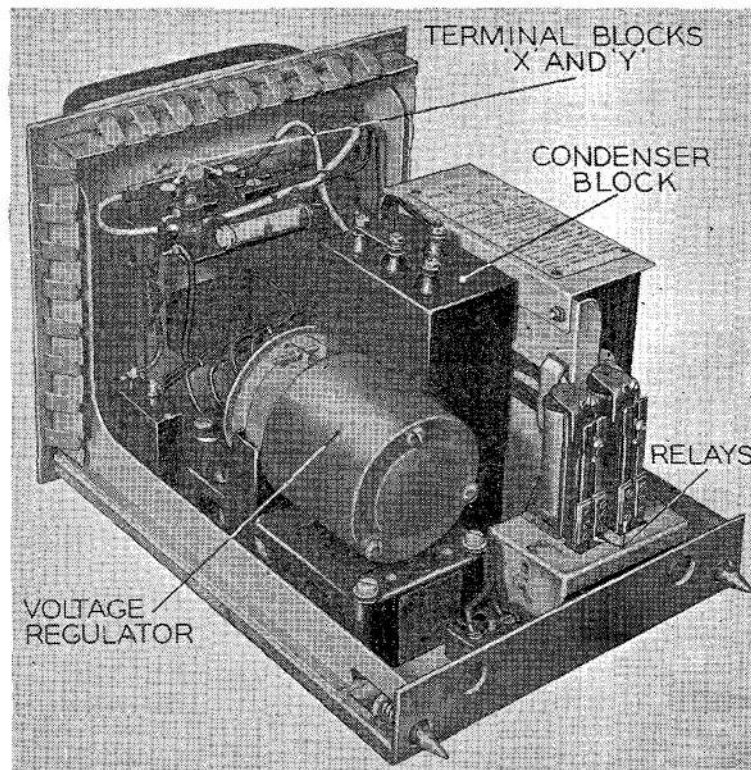

Fig. 1. Control panel, Type 4

### DESCRIPTION

2. The components of the control panel (fig. 1) are carried on a sheet steel base and front panel, a sheet steel screening cover sliding over this chassis; effective contact for screening purposes is provided by a number of spring-loaded contact fingers.

3. The generator output is fed through a capacitor block and fuse to the two output pins which are connected to the radio equipment. The value of the capacitor may be

tive pin 2 and pin 1 of the 6-way plug W200. When this switch is closed the relay is energized and the battery supply fed to the generator.

5. Part of the a.c. supply generated is fed to the selenium bridge rectifier, and the d.c. output from this operates the solenoid of the electro-magnet, controlling the compression of the carbon pile. The output of the rectifier is also fed to a relay  $Rel_1$  through a 10,000-ohm resistance  $R_1$  so that its contacts

**RESTRICTED**

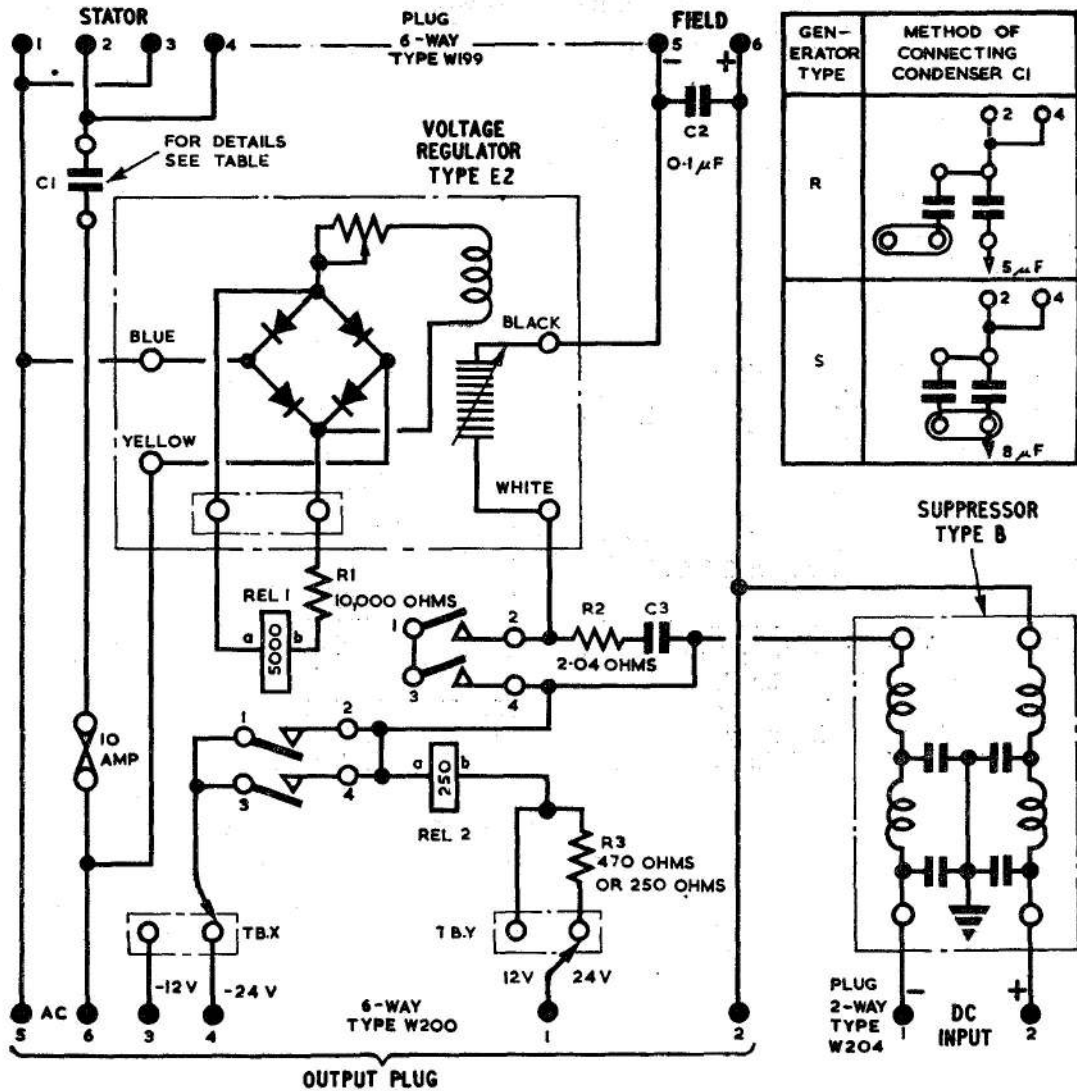

Fig. 2. Circuit diagram

are only closed when the alternator is generating its normal supply. Since these contacts carry the negative supply to the radio equipment, this relay serves to switch off the equipment in the event of voltage drop in the a.c. supply. The terminal block X is connected either to pin 4 or 3 of the 6-way plug W200, according to whether the d.c. supply is 12 or 24 volts; a similar change-over is effected at the terminal block Y to enable a 470-ohm resistance  $R_3$  to be inserted in series with the relay  $Rel_2$  when a 24-volt supply is used.

**INSTALLATION**

6. Care must be taken when installing control panels to connect the leads in the manner indicated in the circuit diagrams. A check should be made that the capacitor unit is correctly connected for the generator in use, and the two adjustable leads must be examined to ensure that they are correctly connected for the voltage of the d.c. supply. If this is not done, serious damage may result.

**SERVICING**

7. Servicing of the control panel is confined

**RESTRICTED**

to the voltage regulator, and this is dealt with fully in Book 1, Sect. 1 of this publication. The contacts of the relays should be cleaned, occasionally with carbon tetrachloride, but care must be taken not to bend the contacts in so doing.

8. For a test for correct operation of the control panel, it should be connected, by means of the appropriate plugs, to a Type R generator with 24-volt excitation and to a 28-volt d.c. supply. Connect the a.c. pins 5 and 6 on the output plug to a non-inductive load taking 6.25 amp. at 85 volts, and to an a.c. voltmeter. The d.c. pins 2 (positive) and 4 are to be connected to a d.c. voltmeter, and the flexible leads inside the panel to the 24-volt terminals. The capacitor link must be in the position appropriate to the type of generator used.

**Note . . .**

*The a.c. voltmeter must be of the rectifier type, free from frequency errors up to 2,500 c/s.*

9. With the generator running, close the switch and check that the relays operate satisfactorily as indicated by the excitation of the generator and the reading of the d.c. voltmeter. Remove the relay cover and operate the switch several times. No exces-

sive sparking must be visible at the relay contacts.

10. Read the relay current indicated on the ammeter in the switch circuit. Gradually reduce the excitation voltage and note the a.c. voltage at which the a.c. operated relay drops out. This must not be lower than 15 volts. Increase the a.c. voltage and note the value at which the relay closes. This must not exceed 70 volts.

11. Change the d.c. supply to 12 volts and reconnect the flexible leads to the 12-volt terminals and the d.c. voltmeter between pins 2 and 3 on the output plug, pin 2 being positive. Run the generator at such a speed that the output is obtainable with the modified excitation (approx. 3,500 r.p.m.), and check that the relays operate satisfactorily as described above.

12. Read the relay current indicated on the ammeter in the switch circuit. This current must lie within the following limits:—

28-volt supply—0.052 to 0.065 amp.

12-volt supply—0.045 to 0.052 amp.

13. Tests should be made for correct regulation and stability as laid down in Book 1, Sect. 1 for the Type E2 regulator.

**RESTRICTED**

This file was downloaded  
from the RTFM Library.

Link: [www.scottbouch.com/rtfm](http://www.scottbouch.com/rtfm)

Please see site for usage terms,  
and more aircraft documents.

