

Now 113D-07135-1

Chapter 21

FREQUENCY PICK-UP BOX

(E.E. TYPE AE 7705, Mk. 1)

LIST OF CONTENTS

	Para.		Para.
Introduction	1	Installation	18
Description		Servicing	19
General	2	Testing	
Bracket and panel assembly	5	General	20
Terminal block	6	Continuity check	21
Potentiometers	7	Functional checks supply connections	22
Inductor assembly...	8	Constant input a.c. voltage/frequency limit checks	23
Bracket and encapsulation assembly	9	Relay operation check	24
Transformer	11	Variable input a.c. voltage/frequency limit checks	25
Capacitor	12	Insulation test	27
Operation	13		
Cooling	17		

LIST OF ILLUSTRATIONS

	Fig.		Fig.
Frequency pick-up box E.E. Type AE 7705, Mk. 1	1	Schematic wiring diagram	3
General view	2	Relay characteristic limit curves...	4
		Insulation test circuit	5

LEADING PARTICULARS

Frequency pick-up box, E.E. Type AE 7705, Mk. 1 ...	Ref. No. 5UC/6472
A.C. voltage	115V
Relay operating voltage	
Normal	28V d.c.
Minimum	25V d.c.
Phase	1 (one)
Frequency (nominal)	400 c/s
Operating altitude	0-60,000 ft.
Rating...	Continuous
Cooling	Natural
Dimensions	
Overall width	6 $\frac{1}{8}$ in.
Overall length (including mounting straps)	5 $\frac{7}{8}$ in.
Overall height (including mounting straps)	3 $\frac{3}{32}$ in.
Weight	4 lb.

RESTRICTED

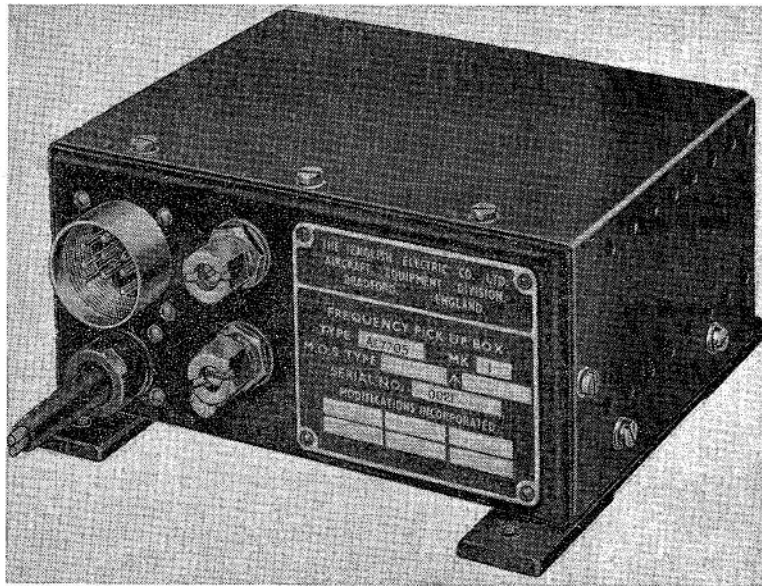

Fig. 1. Frequency pick-up box E.E. Type AE7705, Mk. 1

Introduction

1. The Type AE 7705, Mk. 1, frequency pick-up box is designed for use in multi a.c. generator systems, its function being to control the main contactor of an a.c. generator to prevent it closing when the frequency and voltage are below specified values; thereby preventing the generator being brought on to line until its output is correct. Also to trip the contactor if the frequency of the generator exceeds the specified upper limit.

DESCRIPTION

General

2. The various components of the pick-up box are secured either individually or in sub-assemblies to a chassis and the completed assembly is enclosed by a cover. Both the chassis and the cover are of aluminium alloy. Attached to the chassis are two mounting straps.

3. The low voltage electrical connections to the pick-up box are made by a Plessey standard type plug. The connections for the 115-volt single-phase supply is made by two lengths of Uninyvin 20, these pass through a seal and seal housing and connect to a terminal block. These leads have a minimum

length of 3 feet from the seal face. Internal wiring is carried out in P.V.C. equipment wire.

4. The pick-up box consists of the following sub-assemblies and components, the layout of which can be seen in the general view showing the components, fig. 2.

Bracket and panel assembly

5. The bracket and panel assembly comprises the following components:—

(1) Bracket—this is a mild steel bracket shaped to provide a mounting for the remainder of the assembly components. It is secured in position to the chassis base by two 6 B.A. cheese-head screws locating in two mild steel blocks welded to the base of the bracket, one 4 B.A. cheese-head screw locating in a 4 B.A. nut, locked by a double spring washer and one 4 B.A. countersunk head-screw locating in a 4 B.A. nut, locked by a double spring washer.

(2) Relay—this is an hermetically-sealed relay (REL.1) which plugs into a socket fitted to the bracket.

(3) Capacitors—these are two identical capacitors (C.5 and C.6) fitted to the bracket.

RESTRICTED

(4) **Panel assy.**—this comprises a paxolin panel on which is mounted two resistors (R.1 and R.2), one silicon transistor (TR.1) and two silicon diodes (RE.1 and RE.2). The cable loom providing connections to these components is secured in position by two clips. The assembly is secured to the bracket by four 4 B.A. screws, nuts and spring washers, four thin nuts being utilized as spacers between the panel and the bracket.

Terminal block

6. This is a moulded terminal block to which the a.c. input leads are connected. It is secured to the base of the chassis by three 6 B.A. cheese-head screws locating into three plain nuts, locked by double coil spring washers.

Potentiometers

7. Two setting potentiometers (VR.1 and VR.2) are mounted one above the other in the chassis upright, adjacent to the input socket. These have a lock-nut device, which locks the trimmer screws after adjustment.

Inductor assembly

8. This assembly (L.1) is secured to the base of the chassis adjacent to the bracket and panel assembly. It is secured in position to

the base of the chassis by two 4 B.A. cheese-head screws which locate into the clamps on the body of the inductor, the screws are locked by double spring washers.

Bracket and encapsulation assembly

9. This comprises a mild steel bracket located in position above the inductor assembly, supported by three pillars secured to the chassis base and one 6 B.A. screw locating in an anchor nut secured to the side of the bracket. Mounted in position on the top face of the bracket are three capacitors (C.2, C.3 and C.4) encapsulated in araldite to provide a secure means of mounting and prevent deterioration due to atmospheric conditions. Connections are brought out from the capacitors to turret lugs on one side of the encapsulation.

10. The connection to capacitors C.2, C.3, and C.4 is determined when setting up the tuned circuit during production of the pick-up box.

Transformer

11. This is a Type A.N. transformer (T.1) 1.0 VA, single-phase, 400 c/s, 115V input. It has two output windings, each tapped to give two 5-volt supplies; only one of the 5-volt supplies is used in this application of the transformer. The transformer is secured

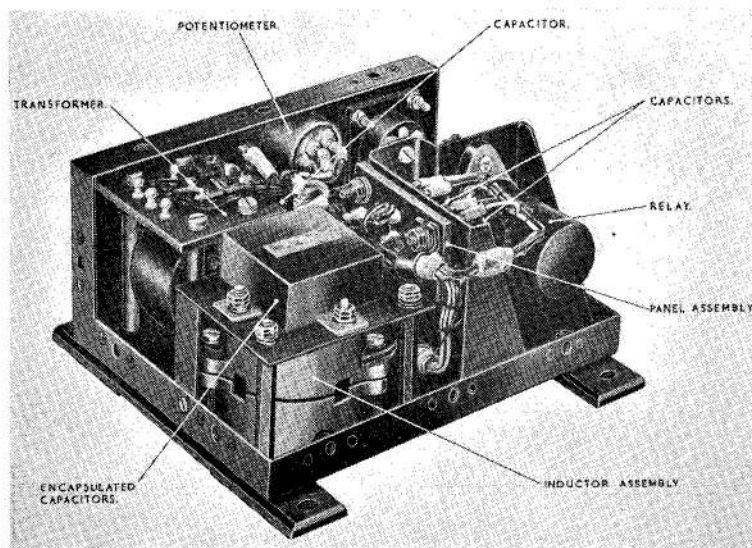

Fig. 2. General view

RESTRICTED

to the chassis base by three 4 B.A. cheese-head screws and one 4 B.A. countersunk head screw, these locate in the four supporting pillars of the transformer. The three cheese-head screws are locked by double spring washers and the countersunk head screw by anti-track enamel.

Capacitor

12. This capacitor (C.1) is mounted on the chassis base adjacent to the transformer; it is secured by two 4 B.A. cheese-head screws locating into plain nuts, locked by lock-washers.

OPERATION

13. The unit consists of a series tuned circuit, the capacitor component of which is adjusted to provide a response curve which will give the relay (REL.1) "pick-up" and "drop out" frequencies of the required values. The tuned circuit is fed from the 5V a.c. secondary of transformer T.1 the input of which is 115V a.c. Fine adjustment control is provided in the form of setting potentiometers (VR.1 and VR.2) which add or subtract resistance in the tuned circuit, varying the amplitude of the response curve and adjust the oscillatory voltage developed across it.

14. This voltage is half-wave rectified, smoothed and applied to the base of a transistor. The collector emitter current of the transistor is proportional to the base voltage; therefore relay (REL.1) which is connected in the collector circuit of the transistor between d.c. positive and the collector, will operate at the preset frequencies of the tuned circuit.

15. The relay has four sets of contacts, these are connected to provide, two sets which are normally closed and two sets which are paralleled and normally open. The contacts control the operation of an alternator contactor and also provide through suitable external circuitry indication of the operation of the pick-up box.

16. A rectifier (RE.2) is connected across the relay coil to ensure quick field decay on reduction of current flow and so ensure positive action of the relay.

COOLING

17. The cover of the pick-up box is perforated, this provides a natural means of

cooling, by allowing dissipation of heat from within the unit.

INSTALLATION

18. The pick-up box can be mounted in any position and secured by four bolts through the four holes provided in the two mounting straps.

SERVICING

19. On receipt of a new or reconditioned pick-up box and prior to installation in the aircraft, the pick-up box should be inspected for corrosion and damage to the case, all components and electrical connections. It is essential that the frequency settings and operation of the relay be within satisfactory limits. Therefore, replacement of defective components and the necessary testing and adjustment should only be completed by servicing units suitably equipped to do so, otherwise the complete switchbox should be returned to stores for repair in accordance with current authorized procedure.

TESTING

General

20. If for any reason it is suspected that the pick-up box or any of its components are not operating correctly, the following checks and tests should be completed to ensure the serviceability of the unit. In the functional checks the frequency meter used should be accurate to within plus or minus 1.0 per cent.

Continuity check

21. Carry out a continuity check of the complete unit, referring to the schematic wiring diagram (*fig. 3*) for details of internal connections. Ensure during the check that potentiometers VR.1 and VR.2 are positively locked.

Functional checks supply connections

22. Connect the pick-up box as follows, referring to the schematic wiring diagram (*fig. 3*) for terminal connections:—

- (1) Connect a variable frequency, variable voltage supply, nominally 115V, 400 c/s single-phase, to terminals L and N.
- (2) Connect a variable d.c. supply, nominally 28V d.c., to terminals 7 and 8, terminal 7 to be positive.
- (3) Connect suitable continuity indicators between terminals 1 and 4, 2 and 5, 3 and 6.

RESTRICTED

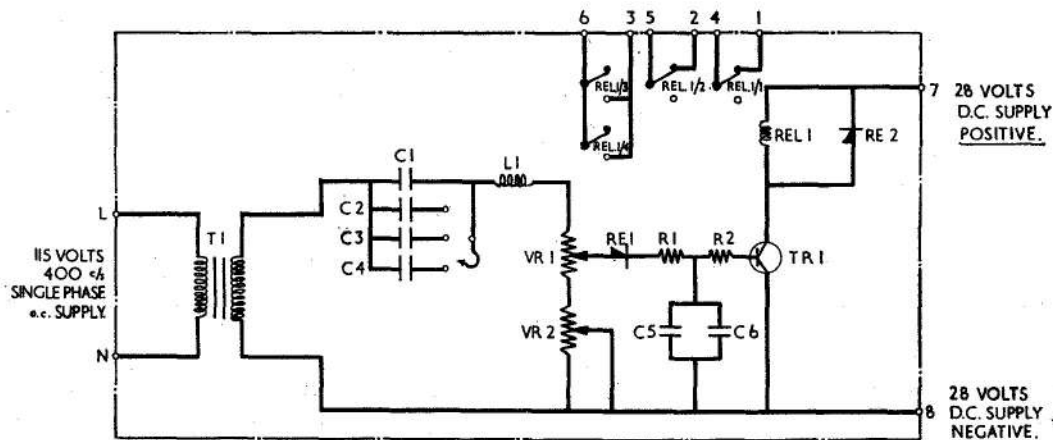

Fig. 3. Schematic wiring diagram

Abbreviations and Key	Resistance Values	Capacitance Values
T1 Transformer 115 V./5 V.	VR1 0-100 Ω	C1 .1 μf.
L1 Inductor 1.250 ± 0.015 Henrys	VR2 0-500 Ω	C2 .005 μf.
RE1 Rectifier	R1 56 Ω	C3 .02 μf.
RE2 Rectifier	R2 560 Ω	C4 .01 μf.
TR1 Transistor		C5 2 μf.
REL1 Relay (Coil)		C6 2 μf.
REL 1/1 REL 1/2 REL 1/3 REL 1/4	} REL 1 Relay Contacts	
VR 1 Variable Potentiometer		
VR 2 Variable Potentiometer		

Constant input a.c. voltage/frequency limit checks

23. Check that with the following applied voltages, the frequencies at which relay "pick-up" and "drop out" occur, are within the limits shown. In these checks the continuity indicator connected between terminals 2 and 5 should be referred to for indication of the operation of the relay.

A.C. voltage supply connected to terminals L and N	D.C. voltage supply connected to terminals 7 and 8 (terminal 7 +ve)	Relay "Pick-up" frequency limits	Relay "Drop out" frequency limits
115	28	360-370	458-492
115	25	360-370	458-492

RESTRICTED

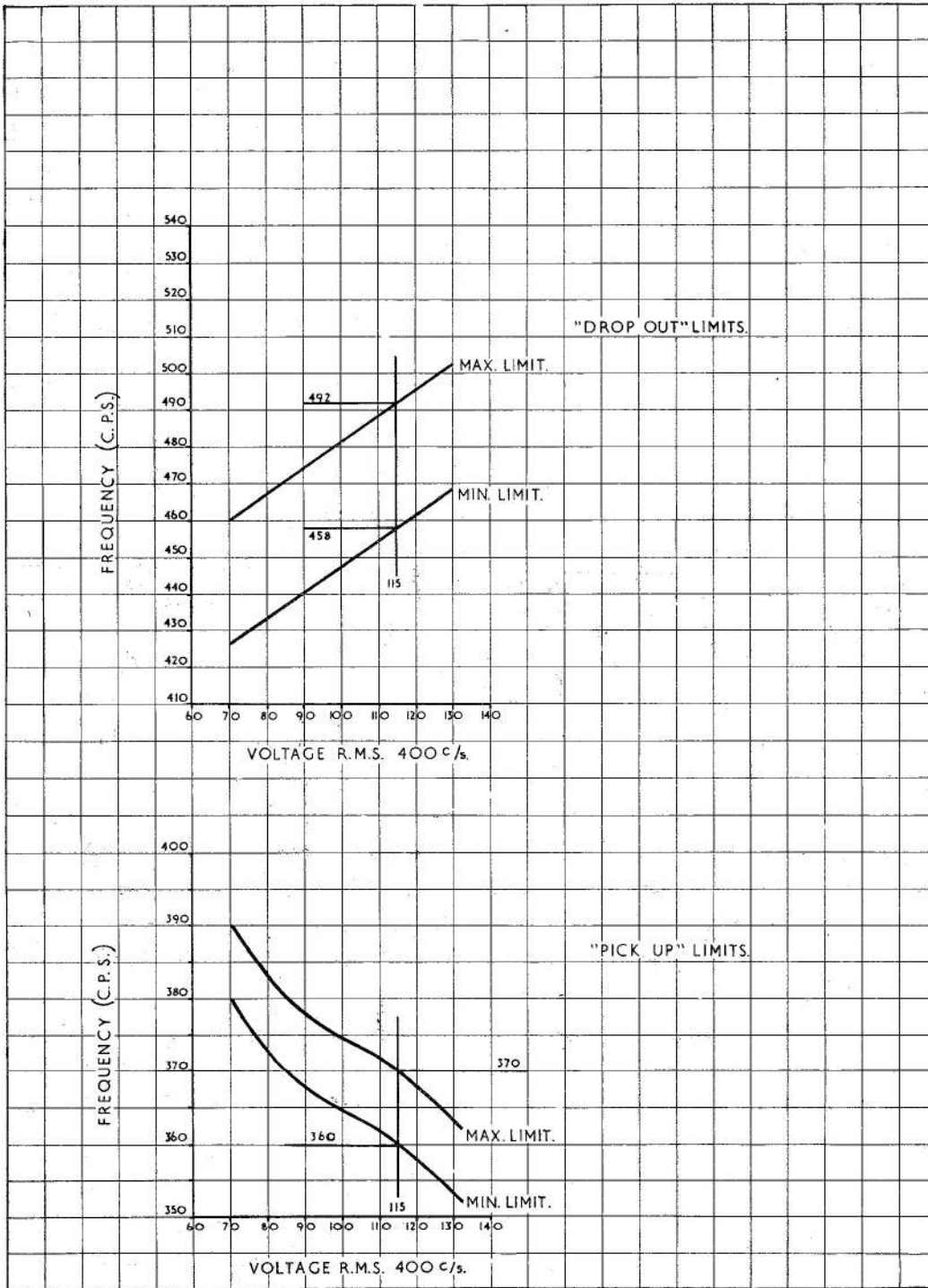

Fig. 4. Relay characteristic limit curves

RESTRICTED

Relay operation check

24. Check, using the continuity indicators, the operation of the relay contacts as follows:—

Continuity indicator connected to terminals:—	Contact position Relay "in" (pick-up)	Contact position Relay "out" (drop out)
1 and 4	Open	Closed
2 and 5	Open	Closed
3 and 6	Closed	Open

Variable input a.c. voltage/frequency limit checks

25. Ensure 28-volts d.c. is applied to terminals 7 and 8, terminal 7 to be positive. Take readings of the frequency at which relay "pick-up" and "drop out" occurs at the following input voltages applied to terminals L and N:—

70, 80, 90, 100, 110, 120 and 130V a.c.

Complete graphs of frequency/a.c. input voltage and compare the characteristics obtained with the limit curves in fig. 4. The characteristics must be within the limits shown.

26. Repeat the checks in para. 25, with 25-volts d.c. applied to terminals 7 and 8 (terminal 7 to be positive).

Insulation test

27. Measure the leakage current using a 0–50 μ A industrial grade ammeter or multimeter type 12889 with a 0.5 megohm ($\frac{1}{4}$ W) resistor in series with the positive probe as shown in fig. 5. Connect the test circuit (fig. 5) to a d.c. supply variable between zero and 28V. Increase the voltage gradually from zero to 28V. The leakage current should not exceed 1.4 μ A when this voltage is applied between each designation shown and the remainder:—

- (1) contact pins in breeze plug shorted together.
- (2) leads L and N.
- (3) frame.

Before removing test circuit decrease voltage gradually to zero. ▶

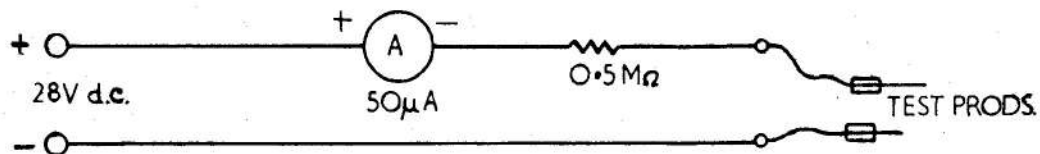
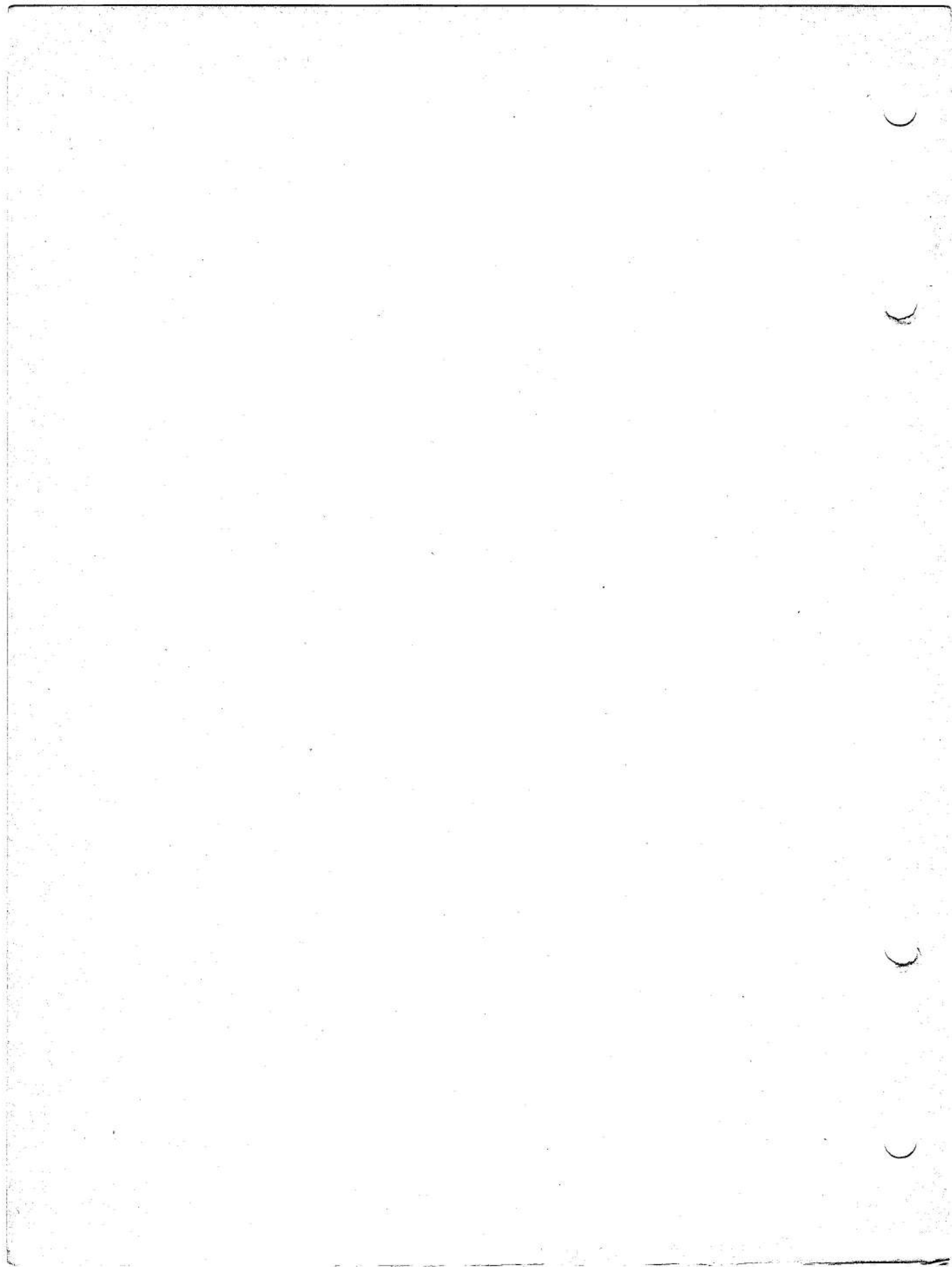

Fig. 5. Insulation test circuit

RESTRICTED



This file was downloaded
from the RTFM Library.

Link: www.scottbouch.com/rtfm

Please see site for usage terms,
and more aircraft documents.



LIGHTNING MK. 1
COVER PITOT HEAD
EB2-88-511