

Chapter 25

UNDERVOLTAGE PHASE SEQUENCE UNIT (E.E. TYPE AE5600)

LIST OF CONTENTS

	Para.		Para.
<i>Introduction</i>	1	<i>Wiring</i>	10
Description	2	Operation	
<i>Base assembly</i>	3	<i>General</i>	11
<i>Bottom board encapsulation</i>	4	<i>Detail</i>	12
<i>Transformers</i>	5	Installation	15
<i>Relay</i>	6	Servicing	16
<i>Potentiometer</i>	7	Testing	
<i>Terminal block</i>	8	<i>Setting up procedure</i>	17
<i>Cover</i>	9	<i>Contact drop test</i>	18

LIST OF ILLUSTRATIONS

	Fig.		Fig.
<i>General view of unit</i>	1	<i>Circuit diagram</i>	3
<i>View of unit with cover removed</i>	2	<i>Diagram of potentiometer connections</i>	4

LIST OF APPENDICES

	App.
<i>Standard serviceability test for under-voltage phase sequence unit, E.E., Type AE5600</i>	A

LEADING PARTICULARS

<i>Undervoltage phase sequence unit, E.E. Type AE5600</i> ...	Ref. No. 5UC/6938
<i>System voltage</i>	115-volts, 3-phase a.c.
<i>Frequency of system voltage</i>	400 ± 50 c/s
<i>Operating limits at 20° C</i>	Relay closes at 102.5 ± 3.5 volts Relay opens at 99.5 ± 1.5 volts
<i>Relay contact rating</i>	3 amperes, non-inductive
<i>Weight</i>	0.7 lb.
<i>Dimensions</i>	2.5 in. × 2.9 in. × 2.31 in.

Introduction

1. The undervoltage phase sequence unit, Type AE5600 provides protection in the 115-volt, 3-phase, 400 c/s system against undervoltage and reverse phase sequence connection. The unit is enclosed in a moulded black nylon cover. Early production models may have transparent covers.

DESCRIPTION

2. The unit comprises the following assemblies; some of these assemblies are linked with others but are described individually to avoid complexity.

Base assembly

3. This is an extruded light alloy component

RESTRICTED

having holes in three of its sides. The holes provide housing for twelve silicon diodes and two transistors which are mounted vertically. The silicon diodes and transistors are fitted in Helsen sleeves prior to mounting in the holes in the base. An anodised aluminium alloy base plate is attached to the base by four 6 B.A. countersunk brass screws.

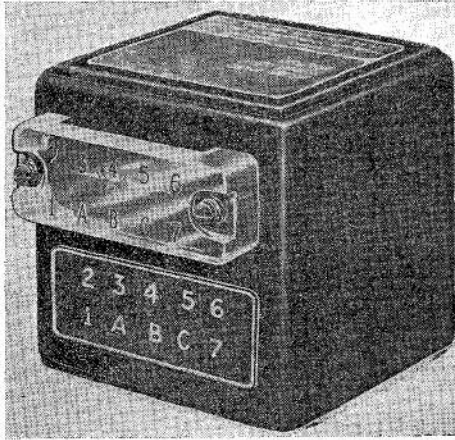

Fig. 1. General view of unit

Bottom board encapsulation

4. This assembly consists of eight resistors, a thermistor and four capacitors mounted on a tag board. Electrical connections from the encapsulation are provided to the base assembly by means of turret lugs and to the upper components of the unit by flying leads. A bonded glass top board is fixed in position and the whole assembly is encapsulated. A transfer bearing the item serial number is

attached to the side of the encapsulation.

Transformers

5. Two transformers are fitted to the unit. The input to both is 115 volts but each have a separate output of 10.3 volts and 26.0 volts. The transformers are mounted on the top board of the encapsulation.

Relay

6. A Type F Clare relay is fitted adjacent to the two transformers. The relay is inserted in a Symel sleeve which provides protection against vibration and mechanical damage. The relay and the transformers are secured by two pressed light alloy brackets. The brackets are fitted above and below the transformers and the complete assembly attached to the base and encapsulated assembly by two stainless steel 6 B.A. cheese-headed screws fitted with light alloy spacers.

Potentiometer

7. A Painton potentiometer is mounted on a light alloy plate and secured by two 6 B.A. cheese-headed screws.

Terminal block

8. A ten-way mounted terminal block is attached to the cover by two fixing screws which are tapped internally to accept the terminal cover fixing screws.

Cover

9. A moulded nylon cover is fitted to the unit and cemented to the base assembly. The terminal cover is retained in position by two captive 6 B.A. screws.

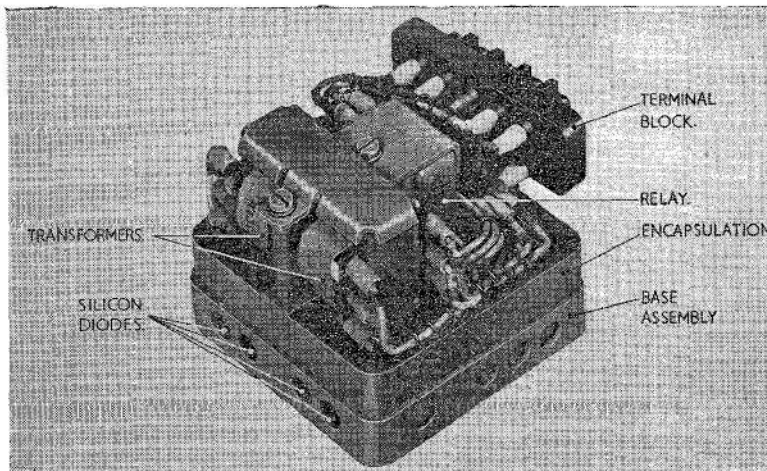

Fig. 2. View of unit with cover removed

RESTRICTED

Wiring

10. Internal connections are made by means of P.T.F.E. equipment wire. Symel 1 mm bore sleeves are fitted over pins and tags after soldering.

OPERATION**General**

11. The unit operates on an input of 115-volts, 400 c/s which is fed to the primary windings of two step down transformers. The outputs from the secondary windings of the transformers supply the voltage and phase sensing circuits which control the operation of a transistorized amplifier circuit. This in turn operates a sealed relay which allows the generator to be connected to its load providing the input voltage is above a predetermined value and the phase sequence is correct. The unit will not allow the generator on the line if an undervoltage or incorrect phase sequence condition exists.

Detail

12. Each transformer has two secondary windings, S1 and S2, providing two separate output voltages. The output of the S1 windings supply the phase sequence circuit whilst the output of S2 windings supply the voltage sensing circuits. These circuits control the operation of a two-stage amplifier circuit consisting of transistors T1 and T2. The amplifier operates the sealed relay which controls the closing of the generator circuit breaker. To enable the relay to close the input voltage must be above a predetermined value and the phase sequence must be correct. To monitor these two quantities simultaneously the dual input and circuit comprising D2, D3, R5, thermistor Thr. and R4 is used. The supply to the amplifier is via R7 and when a signal from the phase sequence and voltage sensing circuit blocks diodes D2 and D3 respectively the amplifier is energized. If either of these signals are absent current flows through the appropriate diode and resistors to earth. In the absence of a blocking voltage to either of the diodes the voltage at the base of the transistor T1 is not sufficient to drive T1 and T2 in series. Diode D4 suppresses the voltage surge which results from the breaking of the relay coil circuit and thereby prevents possible damage to the transistors, it also increases the drop-out time of the unit.

13. The output of the S2 windings of the transformers is fed to the rectifier bridge, Rb, and is reduced by R2, RV1 and R3 to a value suitable for supplying the voltage sensing circuit. The reference in this circuit is zener diode ZD2 which is loaded by the thermistor Thr. and resistors R4 and R5. When the input voltage is within the accepted limits ZD2 breaks down and D3 is blocked. Conversely, if the voltage falls to a value which is determined by the setting of the potentiometer RV1, D3 is not blocked and the amplifier output ceases allowing the relay to open. The opening of the relay contacts is delayed by capacitors C2 and C3. Resistor R8 reduces the relay pull-in-time when the voltage is increasing but has no appreciable effect on the drop out time. The thermistor Thr. is used to reduce variations in the time delay characteristics of the unit which would otherwise occur due to temperature variations.

14. The output of the S1 windings of the transformers provide the supply to the phase sequence circuit. The main components are resistor R1 and capacitor C1 which are connected in two of the lines. The voltage in the third line is considerably greater when the phase sequence is correct than when it is incorrect. The voltage is rectified by diode D1 and if the phase sequence is correct the zener diode ZD1 breaks down and gives a blocking signal to diode D2. Provided diode D3 is also blocked a supply is fed to the amplifier which operates the relay UVRS/1 allowing the generator to be connected to its load. If the phase sequence is incorrect the voltage applied to the zener diode ZD1 is not sufficient to break it down and since diode D2 is not blocked current flows through D2 and R6 instead of into T1.

INSTALLATION

15. Four holes, tapped 4 B.A. for $\frac{3}{8}$ in. long screws are provided in the base of the unit for fixing purposes. Electrical connections to the unit from the aircraft system are made through the terminal block.

SERVICING

16. Examine for damage, deterioration and security of attachment.

RESTRICTED

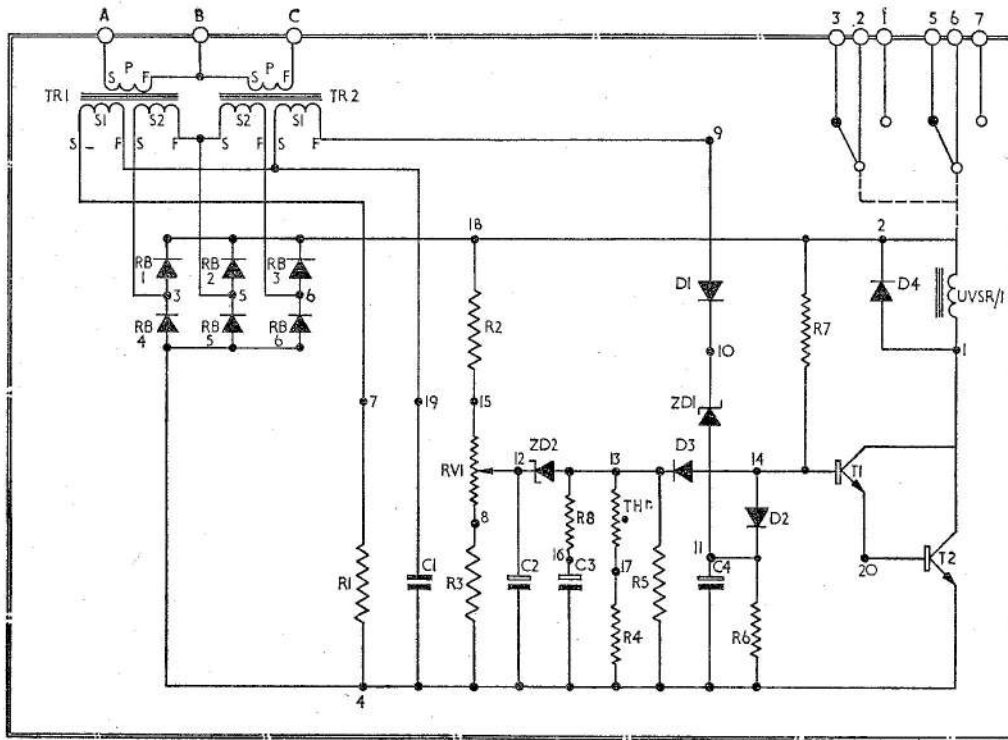

- R1 1KΩ WELWYN AW3101
- R2 680Ω WELWYN AW3115±1%
- R3 220Ω WELWYN AW3115±1%
- R4 2.2KΩ WELWYN
- R5 1.2KΩ WELWYN±1% } AW3101
- R6 1.5KΩ WELWYN
- R7 120KΩ WELWYN METOX TYPE F20
- R8 330Ω WELWYN AW3101
- RV1 100Ω PAINTON FLAT POT. 316510
- C1 .25μf. 200V
- C2 47μf±20% 20V.
- C3 220μf±10% 10V.
- C4 100μf±20% 10V.
- THr. MULLARD VA. 1046

- D1 GEC. DIODE CV4073
- D2 GEC. DIODE CV4073
- D3 GEC. DIODE CV4073
- D4 GEC. DIODE CV4073
- ZD1 GEC. SX32
- ZD2 GEC. SX68
- T1 TEXAS INST. 2S004
- T2 TEXAS INST. 2S017
- RB 6 OFF GEC. DIODE CV4073

TR1
TR2
P=115V. 400 C/S.
S1=10V.
S2=26V.
UVSR/1 C.P. CLARE TYPE RP7630/G7 975Ω ± 10%

Fig 3. Circuit diagram

TESTING

Setting-up procedure

Note . . .

This procedure need not be carried out if the functional test of the unit is satisfactory.

17. (1) Remove cover from unit using a thin bladed knife or other suitable tool; care must be taken not to damage cover.
- (2)
- (3) Set potentiometer to extreme clockwise position.
- (4) Connect a 3-phase, 400 c/s, 115-volt variable supply of correct phase

sequence (A-B-C) to terminals, A, B, C and a suitable continuity tester between terminals 1 and 2.

- (5) At a setting of 115-volts the relay contacts should close.
- (6) Reduce the supply voltage to 99.5 volts and adjust the potentiometer until the relay contacts open.
- (7) Increase the supply voltage to 106 volts to close relay contacts.
- (8) Decrease the supply slowly, repeat slowly, until the contacts of the relay open; this should occur at 99.5 volts. If this does not happen re-adjust the potentiometer slightly and repeat opera-

RESTRICTED

tion from foregoing paragraph until correct setting is achieved.

(9) **▶▶**

(10) Fit cover on unit and cement in position using Araldite 'F'.

Contact drop test

18. (1) Connect a 115-volt, 400 c/s, 3-phase, A-B-C phase sequence, supply to terminals A, B and C of the unit. Short terminals 2 and 6 together and apply a d.c. voltage source to terminals 1 and 7 adjusting the current flow to 3 amperes. Break and make the relay contacts ten times by switching the a.c. supply and then measure the millivolt drop across each pair of contacts. The value should not exceed 150 millivolts.

(2) Transfer the d.c. voltage source from terminals 1 and 7 to terminals 3 and 5 and adjust the current flow to 3 amperes. Break and make the relay contacts ten times by switching the a.c. supply and then measure the millivolt drop across each pair of contacts. The value should not exceed 150 millivolts.

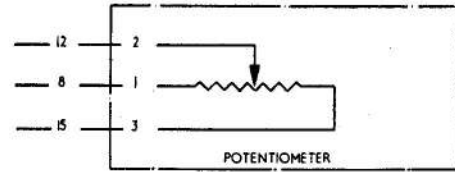
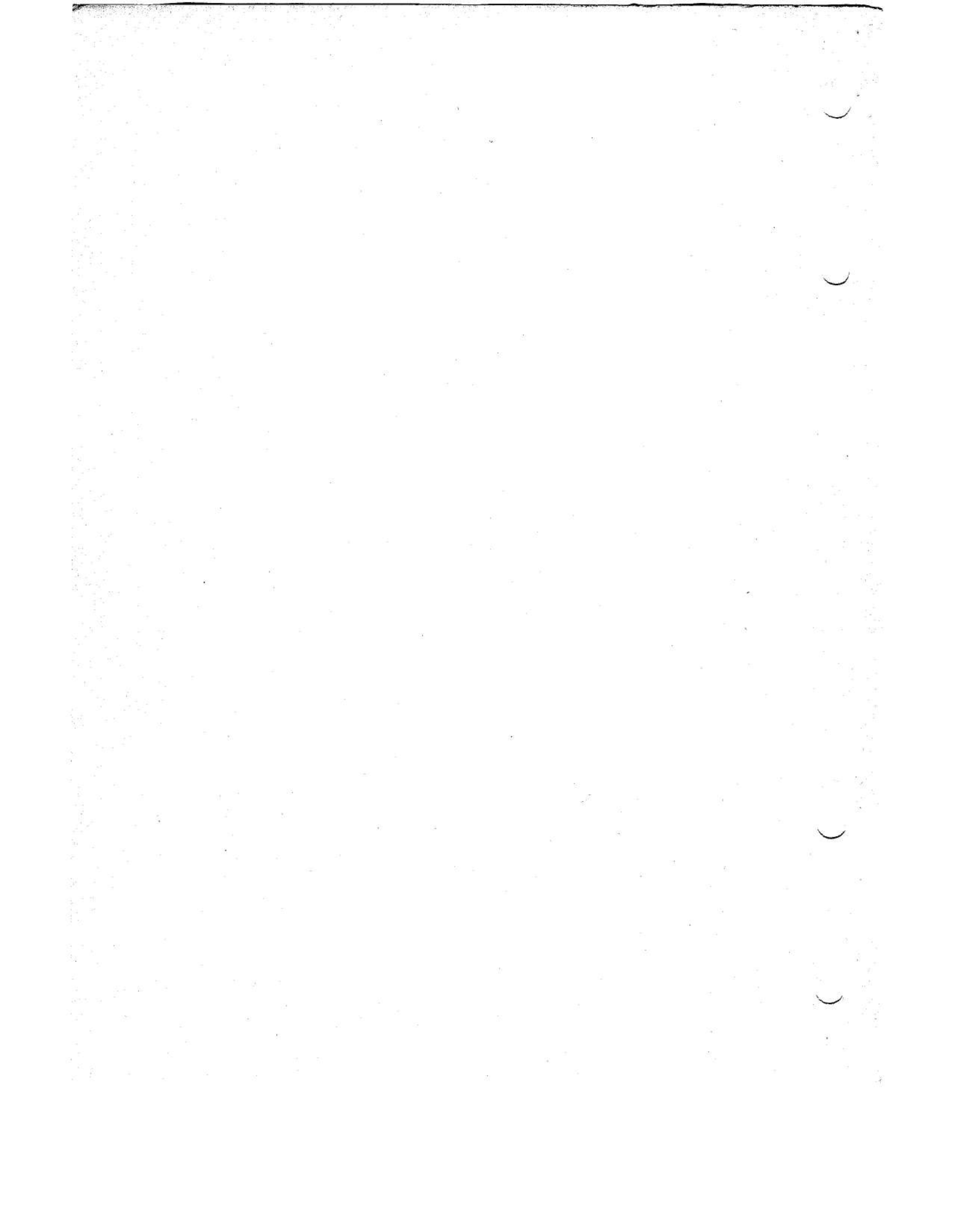

Fig. 4. Diagram of potentiometer connections

RESTRICTED



Appendix A
STANDARD SERVICEABILITY TEST
for
UNDERVOLTAGE PHASE SEQUENCE UNIT
(E.E., TYPE AE5600)

LIST OF CONTENTS

	<i>Para.</i>		<i>Para.</i>
<i>Introduction</i>	1	<i>Wiring check</i>	3
Test equipment	2	<i>Functional test</i>	4
Test procedure		<i>Insulation resistance test</i>	5

LIST OF ILLUSTRATIONS

	<i>Fig.</i>
<i>Test circuit</i>	1
<i>Time delay characteristic curve</i>	2
<i>Insulation test circuit</i>	3

Introduction

1. The following tests may be applied before the phase sequence unit is put into service, or at any time to determine its serviceability.

TEST EQUIPMENT

2. The following test equipment or suitable equivalents, are required:—

- | | | |
|---|--------------------|------------------------|
| (1) Variac | Ref. No. 5P/3450 | |
| (2) Interval timer | 5G/3733 | |
| (3) Continuity tester | } | F19/6625-99- |
| (4) Voltmeters V1 and V2 | | 943-1224 or equivalent |
| (5) 3 resistors
200 ohm 50W | 0632/024/1191 | |
| (6) Switches S1 | 10F/16887 | |
| S2 | 5CW/6435 | |
| S3 | 5CW/877 | |
| S4, S5 | 5CW/6429 | |
| (7) Multimeter | Type 12889 | |
| | Ref. No. 5QP/17447 | |
| (8) Resistor 0.5 megohm $\frac{1}{4}$ w | | |

Note . . .

A 115 volts, 400 c/s, 3-phase supply free from harmonics greater than 2 per cent of the fundamental and fluctuations greater than 0.1 volts is required. The difference between line voltages must not exceed 0.2 volts r.m.s.

Precision grade meters must be used and the a.c. line voltmeters must be accurate to ± 0.75 volts between 95 and 110 volts.

TEST PROCEDURE

Wiring check

3. Check the unit for resistance between the following terminals using an a.c. measuring device.

<i>Terminals</i>	<i>Resistance</i>
A and B	150 \pm 15 ohms
B and C	150 \pm 15 ohms

Functional test

4. (1) Connect unit to test circuit shown in fig. 1.

RESTRICTED

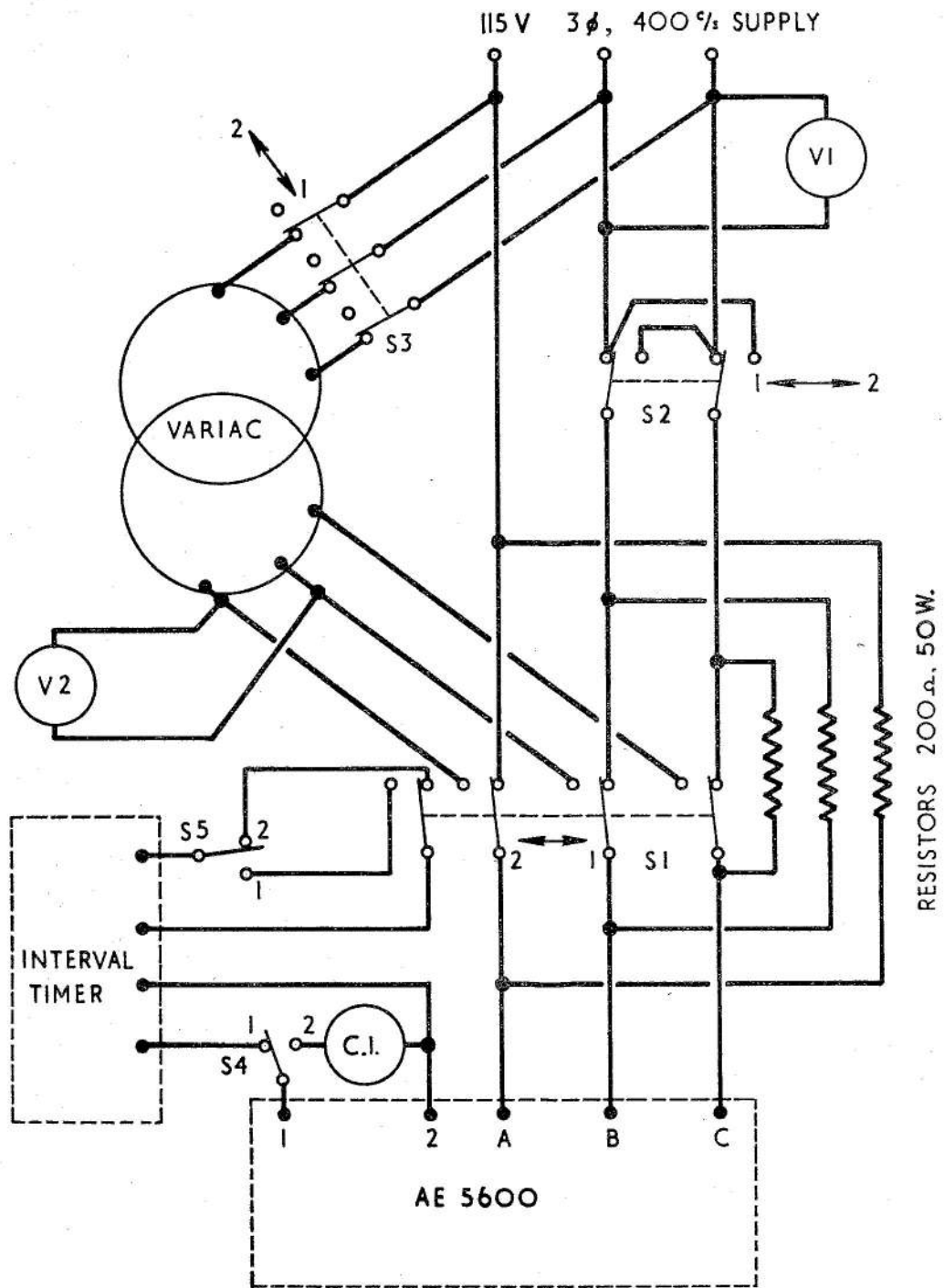

Fig. 1. Test circuit

RESTRICTED

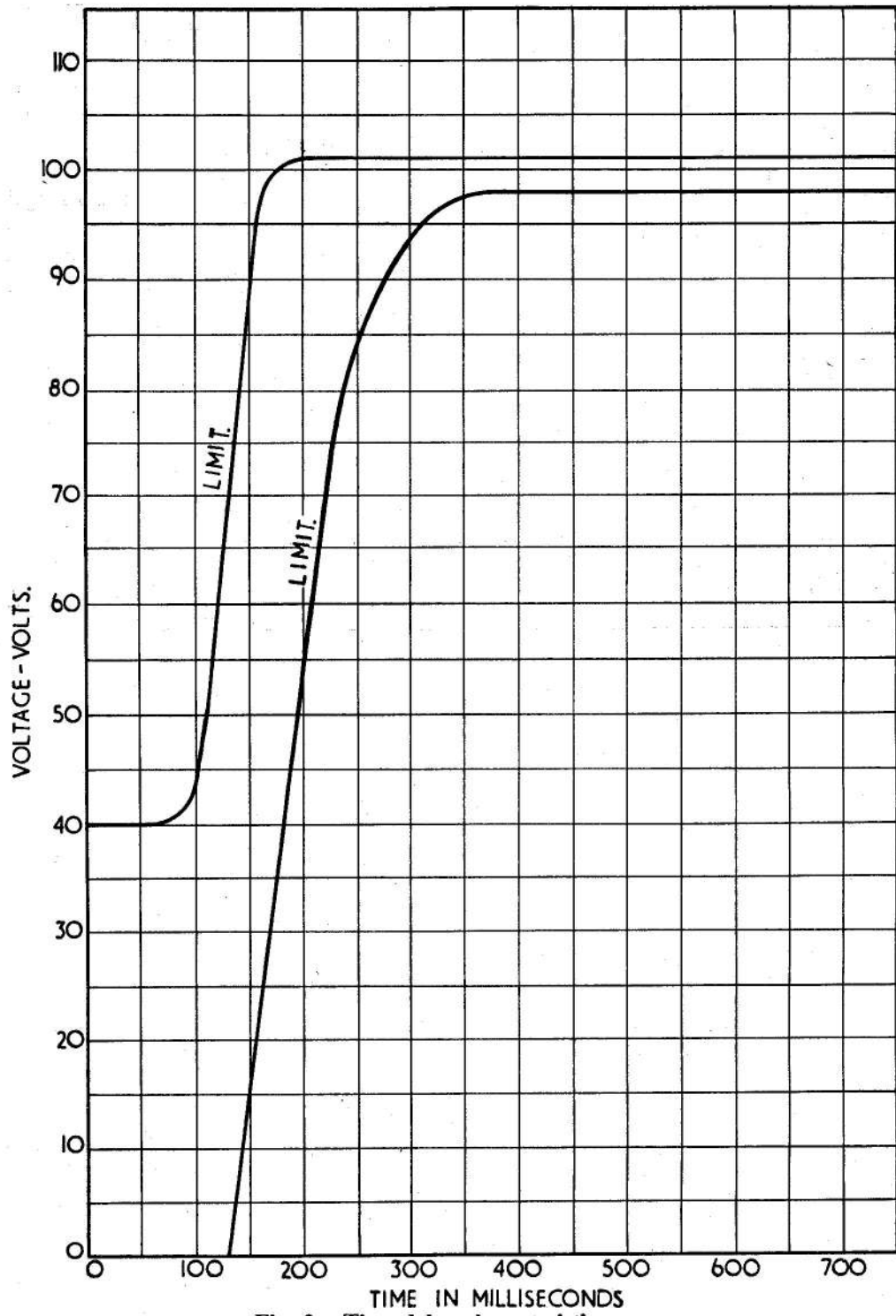

Fig. 2. Time delay characteristic curve

RESTRICTED

(2) Select switches S2 and S3 to position 1 and switches S1, S4, and S5 to position 2. Gradually increase supply voltage V2 until the relay contacts close. This should occur at 102.5 ± 3.0 volts.

(3) Select switches S2 and S4 to position 1 and switches S1, S3, and S5 to position 2. Wind variac down to its mechanical stop. Change switch S1 to position 1 and record the time delay as shown in the interval timer; the reading must not be greater than 60 milliseconds.

(4) Select switch S1, S2, and S4 to position 2. Apply 115 volts to the unit for 5 seconds by placing switch S1 to position 1 during which time the relay contacts should remain open.

(5) With switches S1, S2, S3, S4 and S5 in position 1 adjust variac so that V2 indicates 90 volts. Change switch S1 to position 2 and record time delay as indicated by interval timer. Replace switch

S1 to position 1 and reset timer. Repeat procedure with V2 values of 50 and 25 volts. Finally obtain the highest value of V2 which permits unit to operate. The resulting characteristic is to be contained completely within the envelope shown in fig. 2.

Insulation resistance test

5. Measure the leakage current using a multimeter Type 12889 with a 0.5 megohm ($\frac{1}{4}$ W) resistor in series with the positive probe as shown in fig. 3. Connect the test circuit (fig. 3) to a d.c. variable supply of 28V. The leakage current should not exceed $1.4\mu\text{A}$. When this voltage is applied between:—

- (1) All terminals and frame.
- (2) Terminal A and 1, 3, 5, 7 shorted together.

Before removing test circuit decrease voltage gradually to zero.

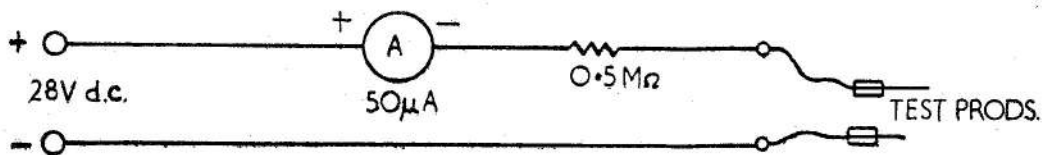

Fig. 3. Insulation test circuit

RESTRICTED

This file was downloaded
from the RTFM Library.

Link: www.scottbouch.com/rtfm

Please see site for usage terms,
and more aircraft documents.

