

Chapter 27

OVERVOLTAGE UNIT, (E.E. TYPE AE 5610)

LIST OF CONTENTS

	Para.		Para.
<i>Introduction</i>	1	Operation	14
Description		Installation	19
<i>General</i>	2	Servicing	20
<i>Base assembly</i>	7	Testing	21
<i>Encapsulation</i>	8	<i>Wiring check</i>	22
<i>Potentiometer assembly</i>	9	<i>Supply and meters</i>	23
<i>Relay</i>	10	<i>Functional test</i>	24
<i>Transformers</i>	11	<i>Setting up procedure</i>	25
<i>Terminal block</i>	12	<i>Contact drop test</i>	26
<i>Cover</i>	13	◀ <i>Insulation test</i>	28 ▶

LIST OF ILLUSTRATIONS

	Fig.		Fig.
<i>General view of unit</i>	1	<i>Functional test circuit</i>	4
<i>View of unit with cover removed</i>	2	<i>Time delay characteristic curve</i>	5
<i>Circuit schematic diagram</i>	3	<i>Potentiometer connections</i>	6
		◀ <i>Insulation test circuit</i>	7 ▶

LEADING PARTICULARS

<i>System voltage</i>	200V, 3-phase, 400 c/s
<i>Operating limits</i>	Unit operates at 217 ± 3V
<i>Relay contact rating</i>	3 amperes, non-inductive
<i>Ambient temperature range</i>	65°C to +100°C
<i>Altitude</i> 0 to 65,000 ft.
<i>Cooling</i> Natural, air
<i>Overall dimensions</i>	2.936 in. × 2.520 in. × 2.312 in.
<i>Weight</i> 11 oz.

Introduction

1. The overvoltage unit, Type AE 5610 is a static sensing unit. Its function is to protect electrical systems of 200-volts, 3-phase, 400 c/s from overvoltage faults. The unit will operate to protect the system, when the voltage rises to 217 ± 3 volts a.c. and in effect disconnects the generator from its load.

DESCRIPTION

General

2. The components of the unit are housed in a black nylon moulded cover closed off at the bottom by a light alloy base plate. The electrical connections are made at a ten-way moulded terminal block mounted on the upper part of the face of the cover. The unit

RESTRICTED

is divided into three sections, see view of unit with cover removed, fig. 2. The lower section consists of the extruded aluminium alloy base on which the diodes, zener diodes and transistors are mounted. The mid section is an encapsulation of resistors and capacitors, bonded directly to the base with Araldite "D". The upper section contains a potentiometer assembly, sealed relay, two transformers and the terminal block. The relay is fitted with a Symel sleeve. All the components of the upper section, with the exception of the terminal block, are mounted on the top board of the encapsulation.

3. The relay and two transformers are fitted between two light alloy brackets, an upper and lower, and the complete assembly is mounted on the encapsulation by two 6 B.A. screws, two spacers and the associated washers of the screws. The spacers are located between the brackets. The outboard screw passes through the encapsulation and screws into a 6 B.A. tapped hole in the base assembly and the inboard screws screw into a 6 B.A. tapped spacer in the encapsulation.

4. The potentiometer assembly is mounted on the encapsulation by two cheese-headed 6 B.A. screws which pass through the encapsulation and screw into 6 B.A. tapped holes in the base assembly.

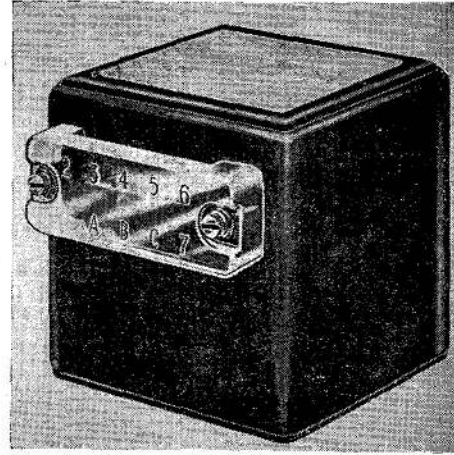

Fig. 1. General view of unit

5. The terminal block is mounted on the cover of the unit by two 6 B.A. fixing screws. The hexagon heads of these fixing screws are counterbored and tapped to accept the 8 B.A. screws securing the terminal block cover to the terminal block. The 8 B.A. screws are held captive on the terminal block cover by two circlips.

6. The cover of the unit is cemented to the base assembly by Araldite "F" and the base

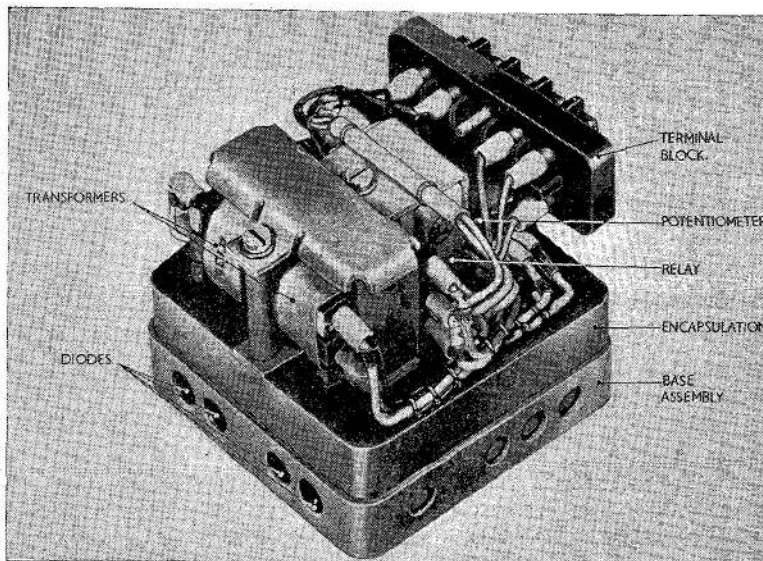

Fig. 2. View of unit with cover removed

RESTRICTED

plate is secured to the underside of the base assembly by four countersunk 6 B.A. screws. Four 0-187 in. dia. holes in the base plate, one at each corner, align with the mounting holes in the base assembly. Access can be gained to the terminal connections of the diodes, zener diodes, transistors, and the encapsulation by removing the base plate.

Base assembly

7. The base is a light alloy extrusion having holes drilled and counterbored horizontally through its four sides and two holes drilled vertically through a lug type internal protrusion on one of the sides. Nine diodes, five zener diodes and three transistors are mounted in Helsyn sleeves in these holes. Four holes, one at each corner, are drilled and tapped 4 B.A. through the base for the purpose of mounting the unit. Another set of four holes, drilled and tapped 6 B.A., in the base accept the screws securing the base plate from below and three of these holes also accept the screws securing the potentiometer, and one of the screws securing the brackets which hold the relay and transformers, from above.

Encapsulation

8. Seven resistors and two capacitors are encapsulated in a synthetic resin compound between the tag board assembly and the bonded glass top of the encapsulation. The resistors and capacitors are mounted on the tag board assembly of the encapsulation. The electrical connections to the diodes, zener diodes and transistors in the base assembly are made through the turret lugs of the tag board assembly and the connections to the components above the encapsulation, are made by P.T.F.E. equipment wire which is brought through the top board. A transfer, bearing the type number and serial number, is affixed to one of the sides of the encapsulation.

Potentiometer assembly

9. A 100-ohm Painton type potentiometer is riveted to a light alloy plate. The setting of the adjusting screw of the potentiometer is locked with Araldite 'F'.

Relay

10. This is a Type F, Clare relay. The contacts of the relay are rated at 3 amperes non-inductive at 28-volts d.c. The relay is sealed and is fitted in a Symel sleeve for protection against vibration and mechanical damage.

Transformers

11. The unit has two open delta-connected transformers. The input to each transformer is 200 volts and the output of each is 26 ± 1 volt.

Terminal block

12. This is a ten-way moulded terminal block. The identity of the terminals is shown on the terminal block cover.

Cover

13. The cover of the unit is a black nylon moulding. The nameplate of the unit is affixed to the top side of the cover.

OPERATION

14. The unit protects the system from a permanent overvoltage of 217 ± 3 volts on a time delay of less than 10 seconds. Voltage is supplied from the system to the primaries of two open delta connected transformers and the stepped down outputs from the secondaries are fed, through a rectifier bridge, to a time delay and temperature compensating network, which controls the operation of three transistors, T1, T2 and T3. The transistors control the operation of the sealed relay OVSR/2.

15. Under normal conditions the rectified voltage supplied from the transformers is not sufficient to break down zener diodes, ZD1, ZD2 and ZD3. Transistor T1 is shut off allowing transistor T2 to be driven through resistor R6 and de-energizing transistor T3. There is no supply to relay OVSR/2.

16. When the voltage rises to 217 ± 3 volts, or above, the zener diodes ZD1, ZD2 and ZD3 break down and if the overvoltage is permanent, transistor T1 is energized. A delay in the energizing of transistor T1 is effected through the RC circuit R4, R5 and C1. Transistor T1 shuts off transistor T2 and drives transistor T3 which energizes relay OVSR/2.

17. The rectifier bridge is formed by diodes D1, D2, D3, D4, D5 and D6. The setting of the potentiometer RV1 controls the voltage at which the zener diodes ZD1, ZD2 and ZD3 break down. The setting is 217 ± 3 volts, system voltage. The function of capacitor C3 is to smooth out the d.c. supply. Zener diodes ZD1, ZD2 and ZD3 provide the reference point in the circuit. Resistor R3 discharges capacitor C1, through diode D7 for operation on subsequent overvoltage faults. Resistors R4 and R5 and capacitor C1 form the RC time delay circuit.

RESTRICTED

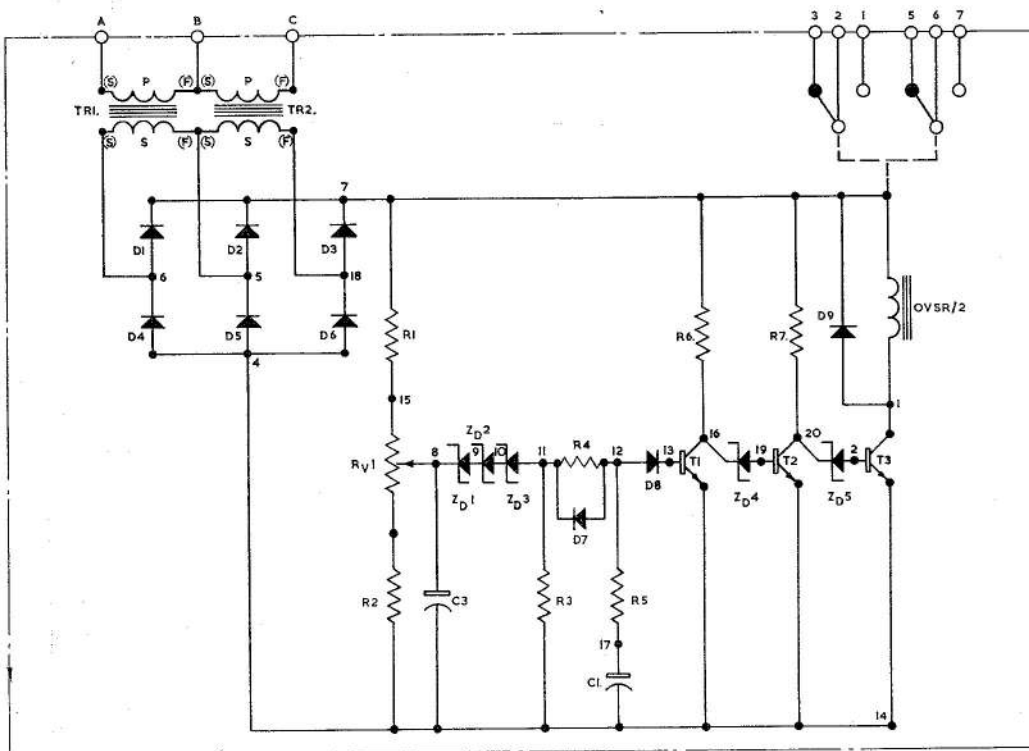

C1	MALLORY TAS 200mf. $\pm 10\%$.	R6	WELWYN METOX TYPE F20 $22K\Omega \pm 5\%$
C3	PLESSEY E3030 $30\mu f + 50\% - 20\%$.	R7	WELWYN AW3115 $6.8K\Omega \pm 5\%$
TR1	P=200V. 400 C/S. S=26V. 50MA.	OVSR	C.P. CLARE RP7630 975 Ω
TR2	P=200V. 400 C/S. S=26V. 50MA.	R _{v1}	PAINTON P316510 100 Ω
D1 TO D9	GEC. DIODE CV4073	T1	TEXAS INST. 2S004
R1	WELWYN AW3115 $390\Omega \pm 1\%$	T2	TEXAS INST. 2S002
R2	WELWYN AW3115 $620\Omega \pm 1\%$	T3	TEXAS INST. 2S017
R3	WELWYN AW3101 $820\Omega \pm 5\%$	ZD1 & ZD2	GEC. SX68
R4	WELWYN AW3115 $5.6K\Omega \pm 5\%$	ZD3	GEC. SX62
R5	WELWYN AW3101 $330\Omega \pm 5\%$	ZD4 & ZD5	GEC. SX82

Fig. 3. Circuit schematic diagram

18. Overall temperature compensation for transistor T1 is effected through zener diodes ZD1, ZD2 and ZD3 and by zener diodes ZD4 and ZD5 for transistors T2 and T3 respectively. The increased gain of the transistors due to a rise in ambient temperature is compensated for by the decreased output of the zener diodes. The opposite is true when the ambient temperature is lowered. Diode D9 suppresses the p.i.v. (peak inverse voltage) across transistor T3 due to the inverse voltage generated by the relay field when the transistor is shut off.

INSTALLATION

19. The unit can be mounted in any attitude. Four holes, drilled and tapped 4 B.A. are provided in the base for mounting purposes. Screws with a grip length of $\frac{3}{8}$ in. should be used in these holes. Electrical connections to the unit are made at the terminal block.

SERVICING

20. When installed in the aircraft the unit should be inspected for the following:—

- (1) Security of mounting screws.
- (2) Security of electrical connections at terminal block.
- (3) Signs of damage or corrosion.

TESTING

21. Each unit should be subjected to the following tests before being released for service.

Wiring check

22. Check the unit for resistance between the following terminals using a d.c. measuring device.

Terminals	Resistance
A-B	500 ± 50 ohms
B-C	500 ± 50 ohms

RESTRICTED

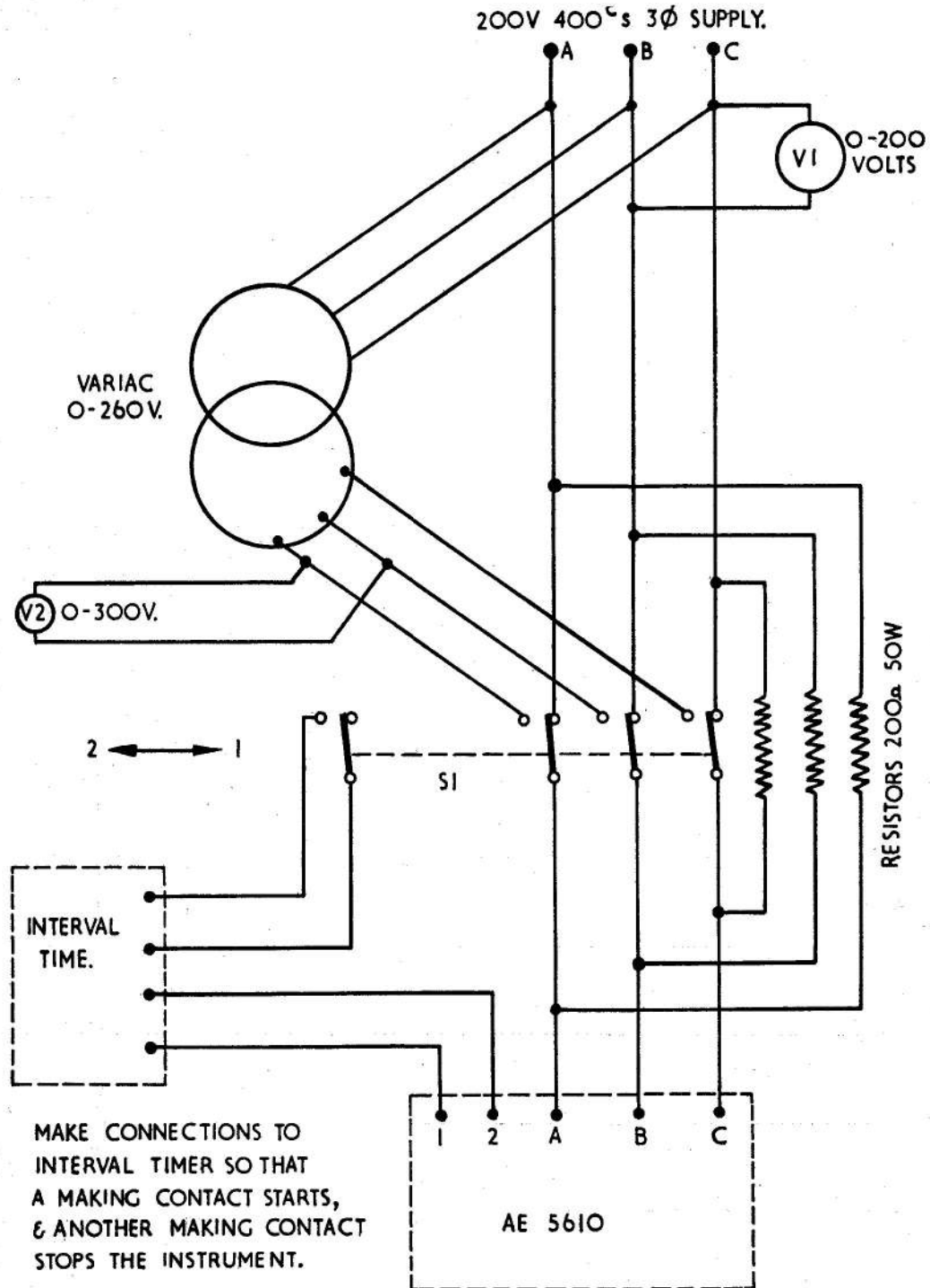

Fig 4. Functional test circuit

RESTRICTED

Supply and Meters

23. A 200-volt (nominal), 3-phase, 400 c/s supply is required. This supply must be capable of variable control and must be free of harmonics greater than two per cent of the fundamental and sub-harmonics greater than one per cent. The difference between line-to-line voltages must not exceed 0.2 volt r.m.s. Precision grade meters are to be used for the a.c. line meters (r.m.s., 400 c/s).

Functional test

24. (1) Connect the unit to the functional test circuit as shown in fig. 4.

(2) Select switch S1 to position 1 and adjust supply so that V1 indicates 200 volts.

(3) Adjust the variac so that V2 indicates 217 volts.

(4) Change switch S1 to position 2 and record time delay as indicated on the interval timer.

(5) Replace switch S1 to position 1 and reset interval timer.

Repeat the procedure with V2 values of 235 and 260 volts. The resulting time delay characteristic curve is to be contained completely within the envelope shown in fig. 5.

Setting up procedure

Note . . .

This procedure is not necessary if the functional test of the unit is satisfactory.

25. Set up the unit as follows:—

(1) Remove cover from unit using a thin bladed knife or other suitable tool; care must be taken not to damage cover.

(2) 

(3) Set the potentiometer to the extreme clockwise position.

(4) Connect a 230-volt, 3-phase, 400 c/s variable supply to terminals A, B, C, of unit.

(5) Connect a suitable continuity indicator to terminals 1 and 2.

(6) At a supply setting of 217 ± 0.0 volts adjust the potentiometer so that the relay contacts close.

(7) Reduce the supply voltage to 215 volts to open relay contacts.

(8) Increase the supply slowly, repeat slowly, and confirm that the close setting of 217 ± 0.0 volts is correct. If it is not

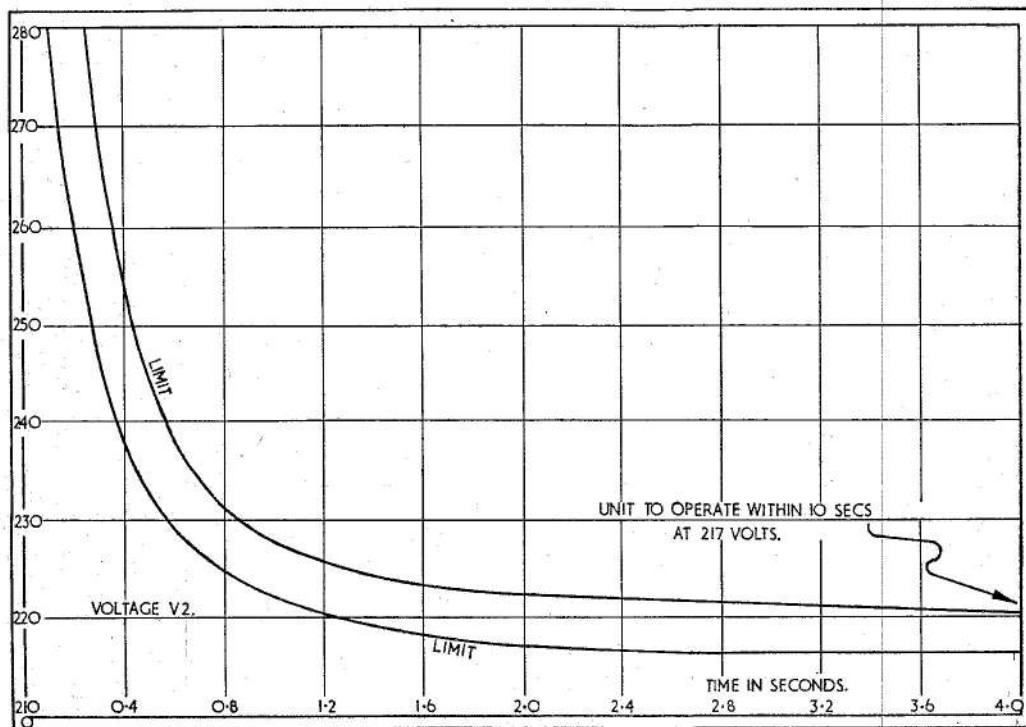

Fig. 5. Time delay characteristic curve

RESTRICTED

correct repeat the procedure from subparagraph (6) until the setting is consistently correct.

(9) Reduce supply voltage slowly to open relay contacts.

(10) Increase supply voltage to 216 volts for a period of 15 seconds, during which time the contacts of the relay should remain open.

(11) 

(12) Fit cover to unit and cement in position using Araldite "F".

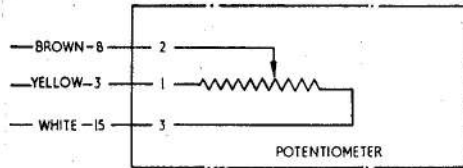

Fig. 6 Potentiometer connections

Contact drop test

26. (1) Connect a 220-volt, 3-phase, 400 c/s supply to terminals A, B, C of the unit.
- (2) Short terminal 2 to terminal 6.
- (3) Apply a d.c. voltage source to terminals 1 and 7.
- (4) Adjust the current flow to 3 amperes.

(5) Break and make the relay contacts 10 times by switching the a.c. supply and then measure the millivolt drop across each pair of contacts; the contact drop value should not exceed 150 millivolts.

27. (1) Transfer the d.c. source from terminals 1 and 7 to terminals 3 and 5.
- (2) Adjust current flow to 3 amperes.
- (3) Allow contact to break and make 10 times by switching the a.c. supply and measure the millivolt drop across each pair of contacts; the contact drop value should not exceed 150 millivolts.

Insulation test

28. Measure the leakage current using a 0.50 μ A industrial grade ammeter or multimeter type 12889 with a 0.5 megohm ($\frac{1}{4}$ W) resistor in series with the positive probe as shown in fig. 7. Connect the test circuit (fig. 7) to a d.c. supply variable between zero and 28V. Increase the voltage gradually from zero to 28V. The leakage current should not exceed 1.4 μ A when this voltage is applied between:—

- (1) all terminals and frame.
- (2) terminal A and 1, 3, 5 and 7 shorted together.

Before removing test circuit decrease voltage gradually to zero.

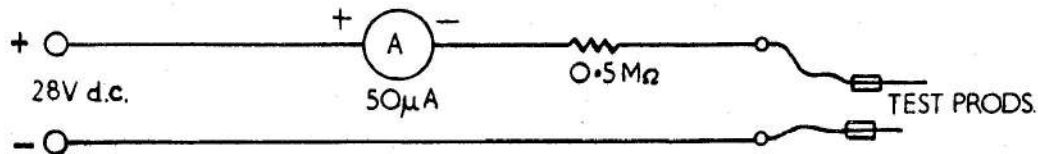
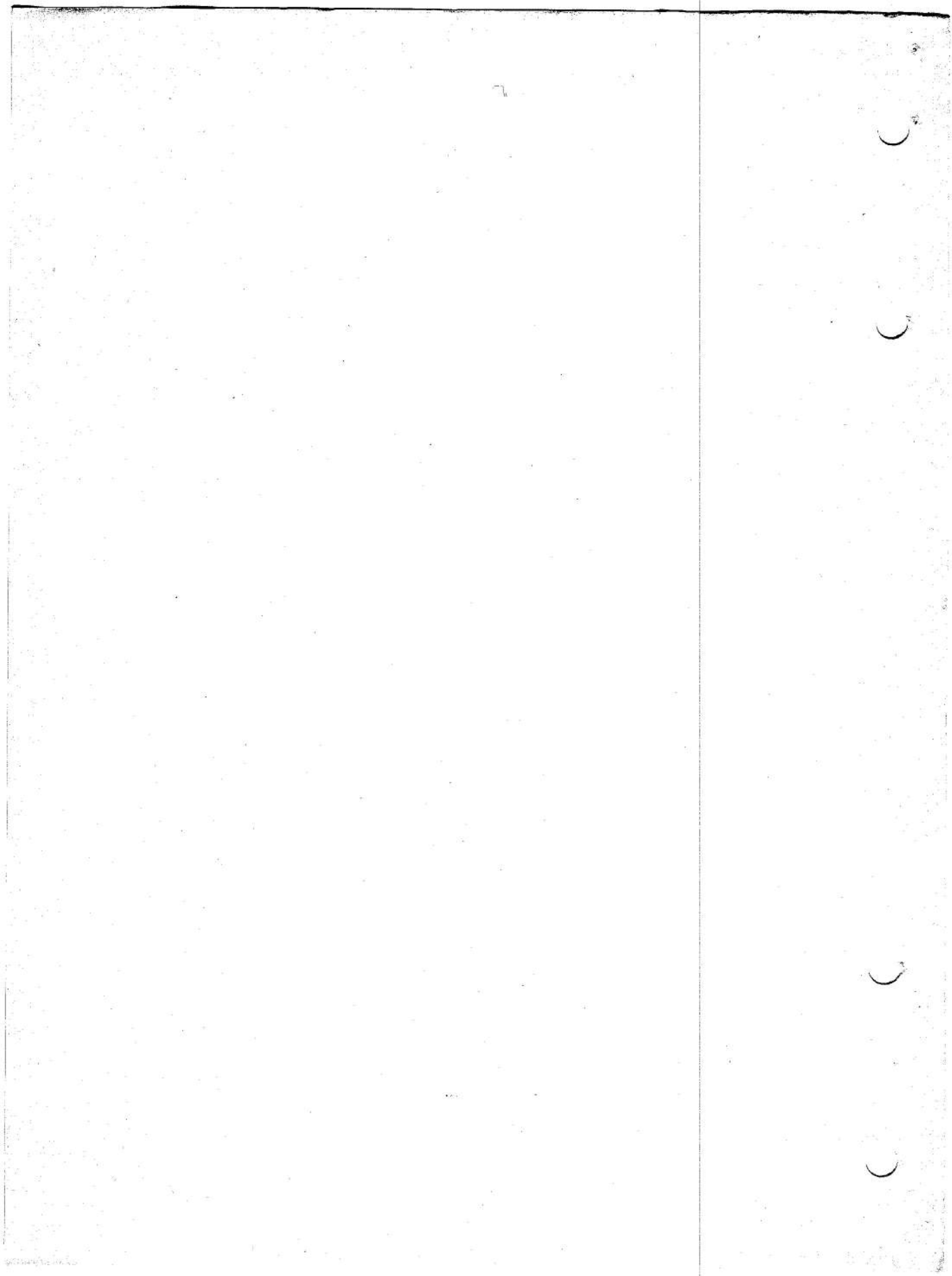

Fig. 7. Insulation test circuit

RESTRICTED





This file was downloaded from the RTFM Library.

Link: www.scottbouch.com/rtfm

Please see site for usage terms, and more aircraft documents.

