

Now 113D-1006-1

Chapter 28 DIFFERENTIAL PROTECTION UNIT, E.E., TYPE AE5620

LIST OF CONTENTS

	Para.		Para.
<i>Introduction</i>	1	<i>Operation</i>	15
Description		Installation	18
<i>General</i>	2	Servicing	19
<i>Base assembly</i>	8	Testing	20
<i>Encapsulation</i>	9	<i>Wiring check</i>	21
<i>Potentiometer assembly</i>	10	<i>Supply and meters</i>	22
<i>Relay</i>	11	<i>Functional test</i>	23
<i>Transformers</i>	12	<i>Setting up procedure</i>	24
<i>Terminal block</i>	13	<i>Contact drop test</i>	25
<i>Cover</i>	14	<i>Insulation test</i>	26

LIST OF ILLUSTRATIONS

	Fig.		Fig.
<i>General view of unit</i>	1	<i>Functional test circuit</i>	4
<i>View of unit with cover removed</i>	2	<i>Potentiometer connections</i>	5
<i>Wiring diagram</i>	3	<i>Contact drop test circuit</i>	6

LEADING PARTICULARS

<i>System voltage</i>	200V, 3-phase, 400 c/s
<i>Operating limits</i>	42 ± 2 amperes
<i>Relay contact rating</i>	3 amperes, non-inductive
<i>Ambient temperature range</i>	-65°C to +100°C
<i>Altitude</i>	0 to 65,000 ft.
<i>Cooling</i>	Natural, air
<i>Overall dimensions</i>	2.936 in. × 2.520 in. × 2.312 in.
<i>Weight</i>	11 oz

Introduction

1. The differential protection unit, Type AE 5620 is static sensing and provides protection against line to line and line to earth faults in 200-volt, 3-phase, 400 c/s systems. The unit operates in conjunction with a current transformer network when a differential of 42 ± 2 amperes exist in any protected line of the system.

DESCRIPTION

General

2. The components of the unit are enclosed in a black nylon cover which is closed off at the bottom by a base plate. Electrical connections are made at a terminal block mounted on the cover.

3. The unit is divided into three sections, see view of unit with cover removed, fig. 2.

RESTRICTED

The lower section consists of the extruded aluminium alloy base on which the diodes, zener diode and transistor are mounted. The mid section is an encapsulation of resistors and capacitors. Araldite 'D' bonds the encapsulation directly to the base. The upper section has a potentiometer assembly, sealed relay, two transformers and the terminal block. All the components of the upper section, with the exception of the terminal block, are mounted on the top board of the encapsulation.

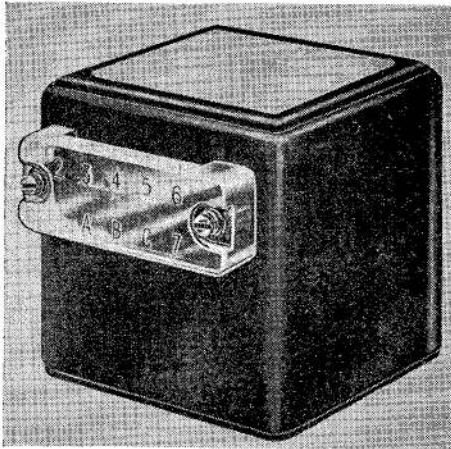

Fig. 1. General view of unit

4. The relay and two transformers are fitted between two light alloy brackets, an upper

and lower, and the complete assembly mounted on the encapsulation by two 6 B.A. screws, two spacers and the associated washers of the screws. The spacers are positioned between the brackets. The out-board screw passes through the encapsulation and screws into a 6 B.A. tapped hole in the base assembly and the inboard screw screws into a 6 B.A. tapped spacer in the encapsulation.

5. The potentiometer assembly is mounted on the encapsulation by two cheese-headed 6 B.A. screws that pass through the encapsulation and screw into 6 B.A. tapped holes in the base assembly.

6. The terminal block is mounted on the upper part of the face of the unit cover by two 6 B.A. fixing screws. The hexagon heads of these fixing screws are counterbored and tapped to accept the 8 B.A. screws securing the terminal block cover to the terminal block. Two circlips hold the 8 B.A. screws captive on the terminal block cover.

7. Araldite 'F' is used to cement the cover of the unit to the base assembly and the base plate is secured to the underside of the base assembly by four countersunk 6 B.A. screws. Four 0.187 in. holes in the base plate, one at each corner, align with the mounting holes in the base assembly. Removal of the base plate affords access to the terminal connections of the diodes, zener diode, transistor and encapsulation.

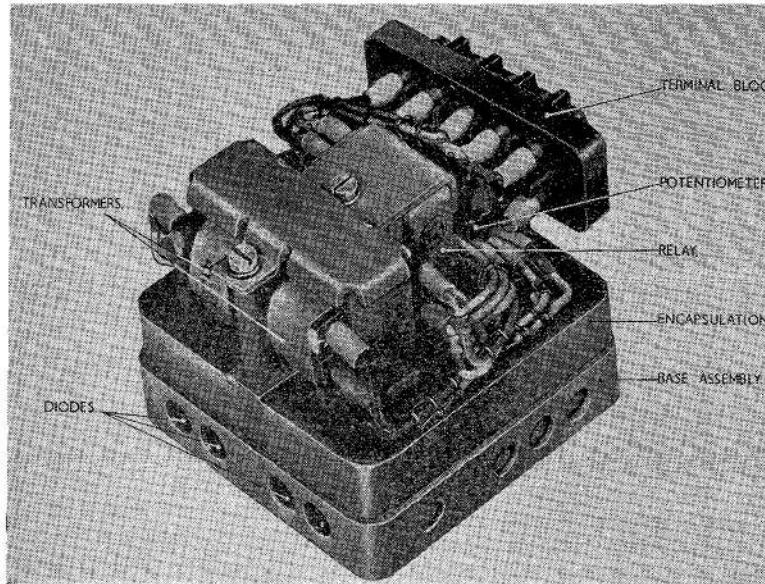

Fig. 2. View of unit with cover removed

RESTRICTED

Base assembly

8. The base is a light alloy extrusion. Holes are drilled and counterbored horizontally through its four sides and two holes are drilled vertically through a lug type internal protrusion on one of the sides. Nine diodes, one zener diode and one transistor are mounted in Helsyn sleeves in these holes. Four holes are drilled and tapped 4 B.A. through the base, one at each corner, for the purpose of mounting the unit. Another set of four holes, drilled and tapped 6 B.A. in the base accept the screws securing the base plate from below and three of these holes also accept the screws securing the potentiometer, and one of the screws securing the brackets which hold the relay and transformers, from above.

Encapsulation

9. Four resistors and three capacitors are encapsulated in a synthetic resin compound between the tag board and top board of the encapsulation. The resistors and capacitors are mounted on the tag board. Both the tag board and the top board are of bonded glass material. The electrical connections from the encapsulation to the diodes, zener diode and transistor in the base assembly are made through the turret lugs of the tag board and the connections to the components above the encapsulation are made by P.T.F.E. equipment wire which is brought through the top board. A transfer, bearing the type and serial numbers, is affixed to one of the sides of the encapsulation.

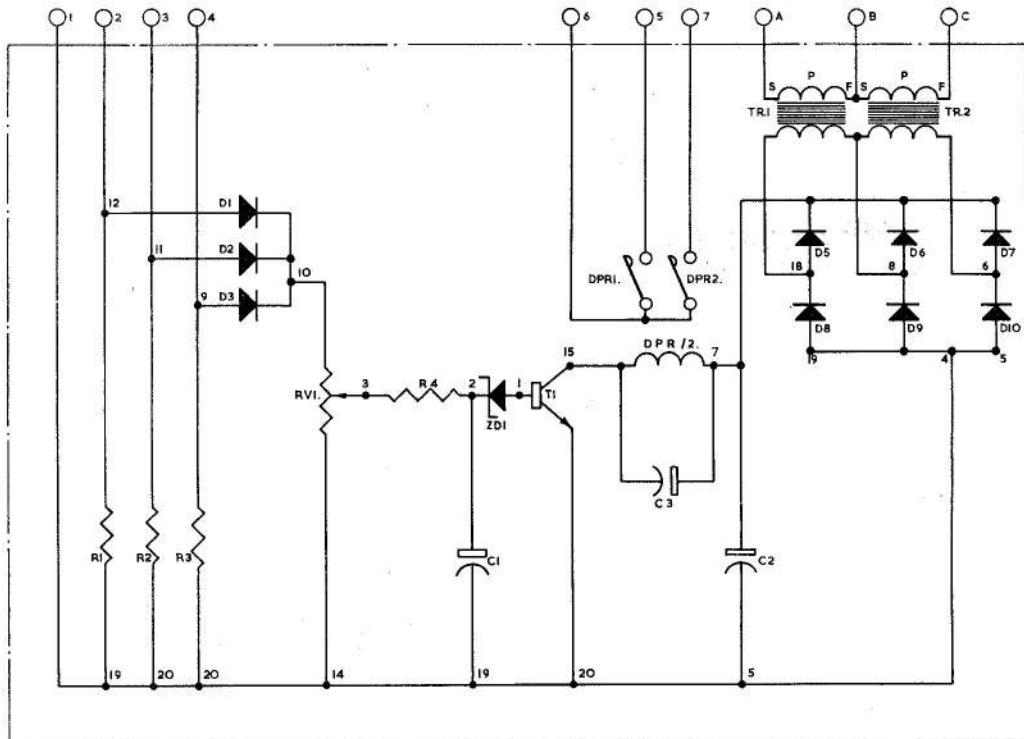

C1	PLESSEY 30 μ f. 30V. E3030	R1	PAINTON P5306 48 Ω \pm 5%	} OVERALL TOLERANCE \pm 1%
C2	PLESSEY 12 μ f. E1270	R2	PAINTON P5306 48 Ω \pm 5%	
C3	PLESSEY 12 μ f. E1270	R3	PAINTON P5306 48 Ω \pm 5%	
D1	GEC. SX645	R4	PAINTON MV1A 150 Ω TO RCL111	
D2	GEC. SX645	RV1	PAINTON FLAT POT. 316510 2K Ω	
D3	GEC. SX645	T1	TEXAS INST. 2S017	
D4		TR1	} P=200V. 400 C/S. S=26V. 50MA.	
D5	GEC. DIODE CV4073	TR2		} P=200V. 400 C/S. S=26V. 50MA.
D6	GEC. DIODE CV4073	DPR/1	C.P. CLARE RP 7630 975 Ω	
D7	GEC. DIODE CV4073	ZD1	GEC. SX82	
D8	GEC. DIODE CV4073			
D9	GEC. DIODE CV4073			
D10	GEC. DIODE CV4073			

Fig. 3. Wiring diagram

RESTRICTED

Potentiometer assembly

10. A 2,000 ohm Painton potentiometer is riveted to a light alloy plate. The setting of the adjusting screw of the potentiometer is locked with Araldite 'F'.

Relay

11. This is a Type F, Clare, sealed relay. The contacts of the relay are rated at 3 amperes at 28-volts d.c. A Symel sleeve is fitted on the relay to provide protection against vibration and mechanical damage.

Transformers

12. The unit has two delta connected transformers. The input to each transformer is 200 volts and the output of each is 26 ± 1 volt.

Terminal block

13. This is a ten-way moulded terminal block. The identity of the terminals is shown on the terminal block cover.

Cover

14. The cover of the unit is a black nylon moulding. The nameplate of the unit is affixed to the top side of the cover.

OPERATION

15. The unit operates in conjunction with a current transformer network when a differential of 42 ± 2 amperes exist in any protected line of the system. If the current transformer circuit is unbalanced by a line to line or line to earth fault a signal is injected into the unit. The signal closes the relay of the unit through a static transistorized circuit when the differential amounts to 42 ± 2 amperes and causes the generator to be disconnected from the system.

16. The supply to the unit is 200-volts, 3-phase, 400 c/s. but the unit will still operate satisfactorily when the supply is effectively single-phased by a line to line fault.

17. Referring to wiring diagram, fig. 3, R1, R2 and R3 of the unit act as calibrating resistances and have an overall tolerance of \pm one per cent. Diodes D1, D2 and D3 summate the input from the current transformer network to transistor T1. Zener diode ZD1 is the reference point in the circuit and potentiometer RV1 controls the point at which the zener diode breaks down. Transistor T1 is energized through the zener diode and controls relay DPR/2. Resistor R4 and capacitor C1 effect a slight time delay in the transistor circuit. The a.c. supply is rectified by a bridge formed by diodes D5, D6, D7,

D8, D9 and D10. Capacitors C2 and C3 smooth the rectified d.c. The unit compensates for temperature variance through the combined characteristics of zener diode ZD1 and transistor T1. An increase in the gain of the transistor, due to a rise in ambient temperature, is compensated for by the decreased output of the zener diode. When the ambient temperature is lowered the output of the zener diode increases and compensates for the loss in the gain of the transistor.

INSTALLATION

18. The unit can be mounted in any attitude. Four holes, drilled and tapped 4 B.A., are provided in the base for mounting purposes. Screws with a grip length of $\frac{3}{8}$ in. should be used in these holes. Electrical connections to the unit are made at the terminal block.

SERVICING

19. When installed in the aircraft the unit should be inspected for the following:—

- (1) Security of mounting screws.
- (2) Security of electrical connections at terminal block.
- (3) Signs of damage or corrosion.

TESTING

20. Each unit should be subjected to the following order of tests before being released for service.

Wiring check

21. Check the unit for resistance between the following terminals using a d.c. measuring device.

Terminals	Resistance	Group resistance
A-B	500 ± 50 ohms	} Within 0.48 ohms of each other.
B-C	500 ± 50 ohms	
1-2	48 ± 2.4 ohms	
1-3	48 ± 2.4 ohms	
1-4	48 ± 2.4 ohms	

Supply and meters

22. A 200-volt, 3-phase, 400 c/s supply is required. The supply must be free from harmonics greater than two per cent of the fundamental and sub-harmonics greater than one per cent. The difference between line voltage must not exceed 0.5 volts r.m.s. Precision grade meters are to be used (r.m.s. 400 c/s).

RESTRICTED

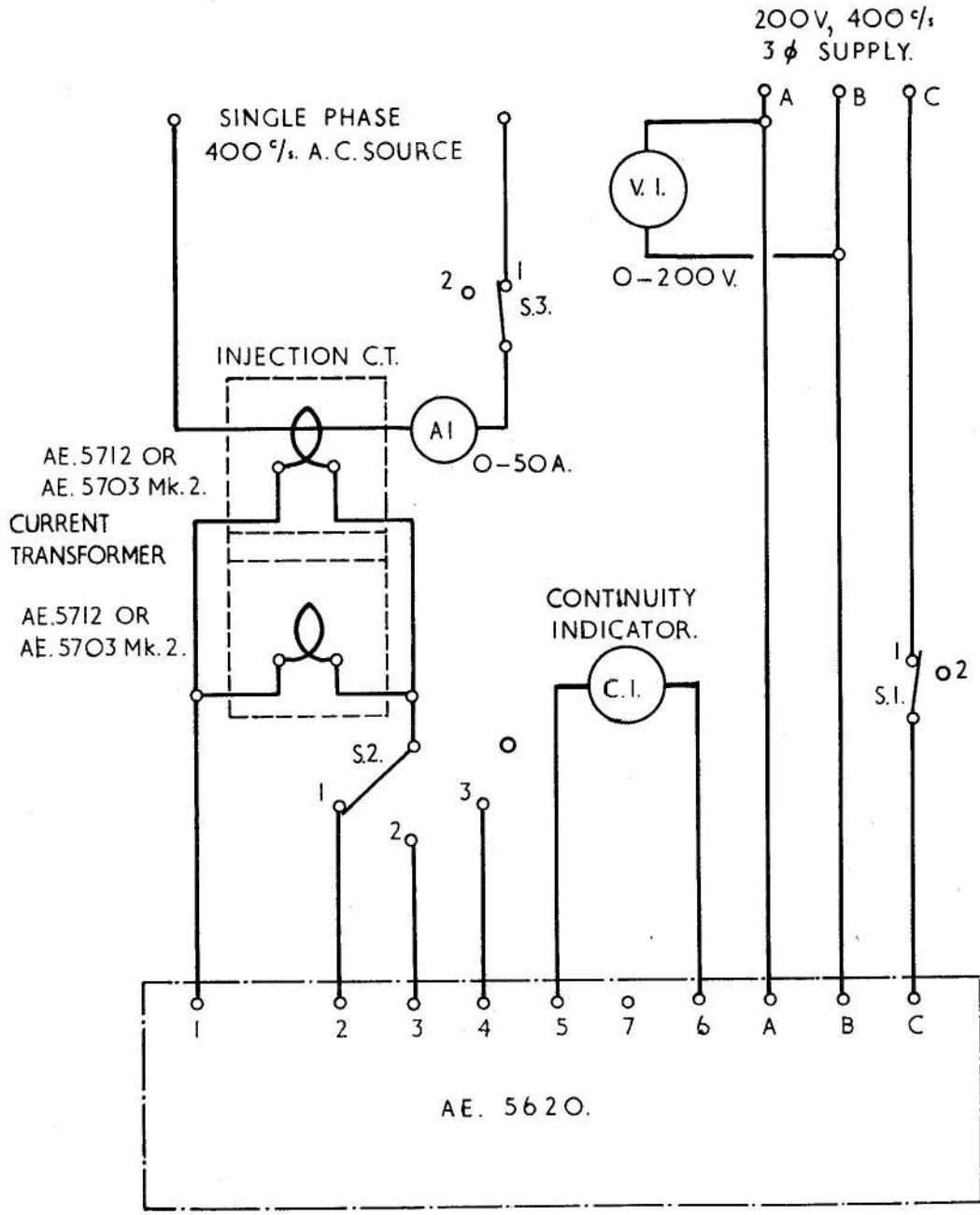

Fig. 4. Functional test circuit

RESTRICTED

Functional test

23. (1) Connect the unit to the functional test circuit shown in fig. 4.
- (2) Select switches S1, S2 and S3 to position 1.
- (3) Adjust supply so that V1 indicates 200 volts.
- (4) Adjust the current flow through the current transformer primary so that the unit operates and record the value of A1.
- (5) Select switch S2 in turn, to positions 2 and 3 and adjust value of A1 on each selection so that unit operates.
- (6) All the values of A1 shall be within 42 ± 1 ampere.
- (7) Reduce the current of the current transformer to zero, select switch S1 to position 2, select any position on switch S2 and adjust the value of A1 to 43 amperes whereupon the unit should operate.

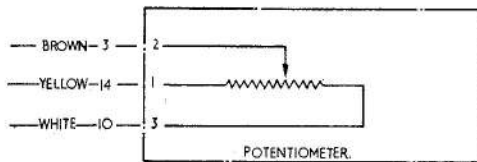

Fig. 5. Potentiometer connections

Setting up procedure

Note . . .

This procedure is not necessary if the functional test of the unit is satisfactory.

24. (1) Remove cover from the unit using a thin bladed knife or other suitable tool; care should be taken not to damage cover.
- (2) Replace potentiometer with new 2,000 ohm Painton potentiometer, see potentiometer connections, fig. 5.
- (3) Set potentiometer RV1 to extreme clockwise position.
- (4) Connect unit to functional test circuit shown in fig. 4.
- (5) Select switches S1, S2 and S3 to position 1.
- (6) Adjust supply so that V1 indicates 200 volts.

(7) Check the d.c. voltage of the unit, using a 0-50 volt instrument, between terminal No. 1 and the coil supply terminal of the relay, which has a green wire with a terminal lug identified as No. 7 connected to it, and reject the unit if the voltage is less than 33 volts.

(8) Adjust the current flow through the current transformer primary so that A1 indicates 42 amperes.

(9) Adjust potentiometer RV1 so that the unit operates as observed on the continuity indicator C1. Note value of A1 and temporarily lock potentiometer RV1.

(10) Select switch S2 to position 2 and carefully adjust the current of the current transformer primary so that the unit operates. Note value of A1.

(11) Select switch S2 to position 3 and carefully adjust the current of the current transformer primary so that unit operates. Note value of A1.

(12) Determine the middle value of A1 for the three selections of switch S2 from sub-paragraphs (9), (10) and (11) and then select the corresponding position on switch S2.

(13) Set the current of the current transformer primary to 42 amperes, unlock potentiometer RV1 and adjust it slowly so that the unit operates. Positively lock the adjusting screw of potentiometer using Araldite 'F'.

(14) Select in turn the other positions of switch S2 and adjust the value of A1 in each selection so that the unit operates. The values should be within 42 ± 1 ampere.

(15) Wipe internal surfaces of cover with industrial alcohol, allow to stand for 15 minutes to clear inflammable fumes, and cement covers to unit using Araldite 'F'.

Contact drop test

25. (1) Connect the unit to the contact drop test circuit shown in fig. 6.
- (2) Select switches S1 and S3 to position 1 and select switch S2 to any position.
- (3) Adjust supply so that V1 indicates 200 volts.

RESTRICTED

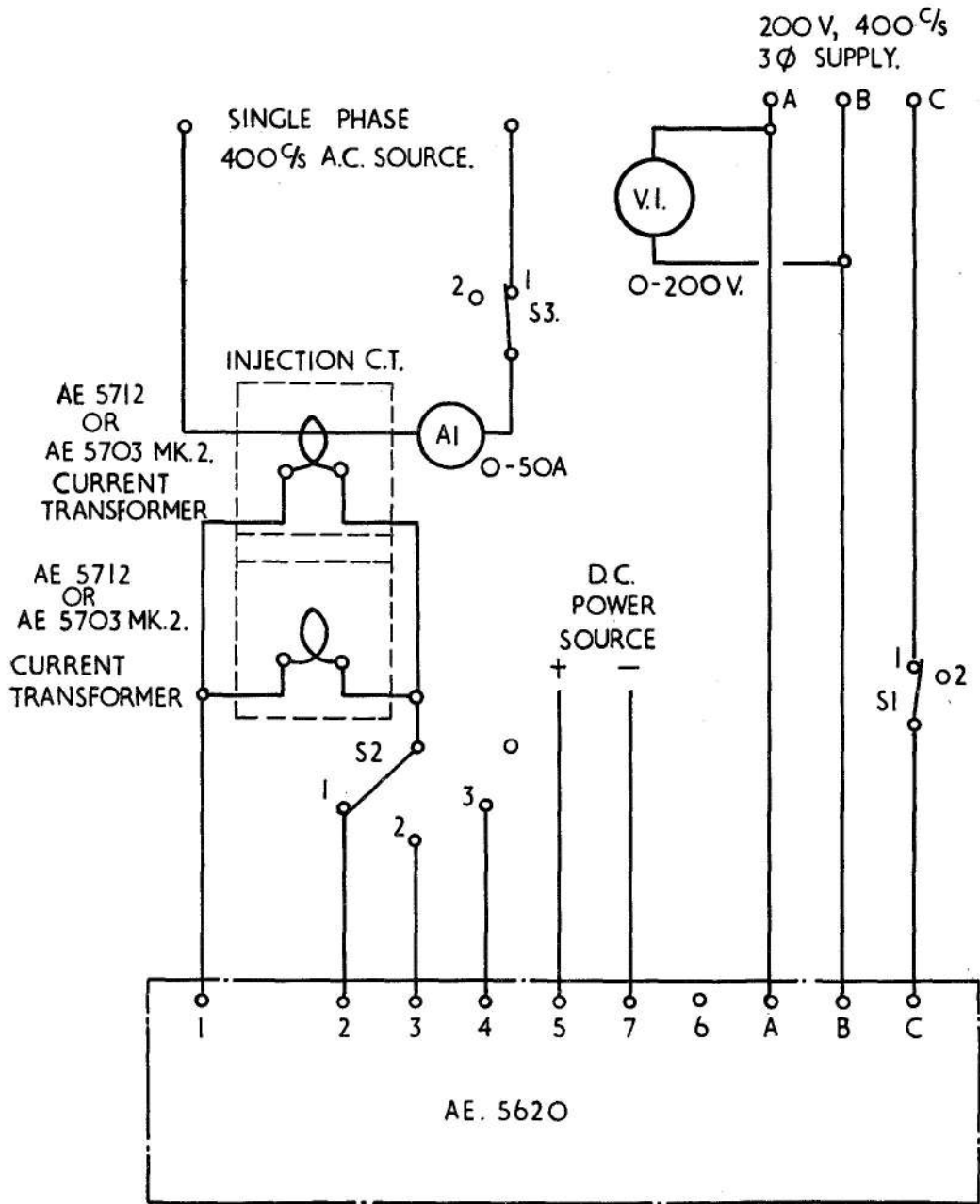

Fig. 6. Contact drop test circuit

RESTRICTED

(4) Adjust current of current transformer primary so that A1 indicates 43 amperes.

(5) Apply d.c. voltage source to terminals 5 and 7 of the unit and adjust current flow to 3 amperes.

(6) Make and break the contacts of the relay ten times by operating switch S3 and then measure millivolt drop across contacts 5 and 6 and 6 and 7; in each case the contact drop value should not exceed 100 millivolts.

Insulation test

26. The insulation resistance shall not be less than 5 megohms when measured at 500 volts d.c. between:—

- (1) All terminals and frame.
- (2) Terminal A to terminal 1.
- (3) Terminal 1 to terminals 5, 6 and 7 shorted together.

RESTRICTED

This file was downloaded
from the RTFM Library.

Link: www.scottbouch.com/rtfm

Please see site for usage terms,
and more aircraft documents.

