

113D -1006-1

Chapter 29

TIME DELAY UNIT, (E.E. TYPE AE5630)

LIST OF CONTENTS

	<i>Para.</i>		<i>Para.</i>
Introduction	1	Testing	
Description	2	<i>Supply and meters</i>	9
Operation	6	<i>Functional test</i>	11
Installation	7	<i>Setting up procedure</i>	12
Servicing	8	<i>Contact drop test</i>	13
		◀ <i>Insulation test</i>	14 ▶

LIST OF ILLUSTRATIONS

	<i>Fig.</i>		<i>Fig.</i>
<i>Time delay unit, E.E. Type AE5630</i>	1	<i>Functional test circuit</i>	4
<i>View of unit with covers removed</i>	2	<i>Diagram of potentiometer connections</i>	5
<i>Wiring schematic diagram</i>	3	◀ <i>Insulation test circuit</i>	6 ▶

LEADING PARTICULARS

<i>Voltage supply</i>	24 to 30 volts d.c. nominally 28 volts
<i>Operating limits of time delay</i>	±10% for set time delay from 1 to 6 secs. ±20% for set time delay below 1 second
<i>Relay contact rating</i>	3 amperes, non-inductive 28 volts d.c.
<i>Ambient temperature range</i> -65°C to +100°C
<i>Altitude range</i> Sea level to 65,000 feet
<i>Mbunting</i> Any attitude
<i>Power consumption</i> 1 to 2 watts
<i>Weight</i> 7 oz.
<i>Overall dimensions</i>	1.79 in. × 1.9375 in. × 1.79 in.

RESTRICTED

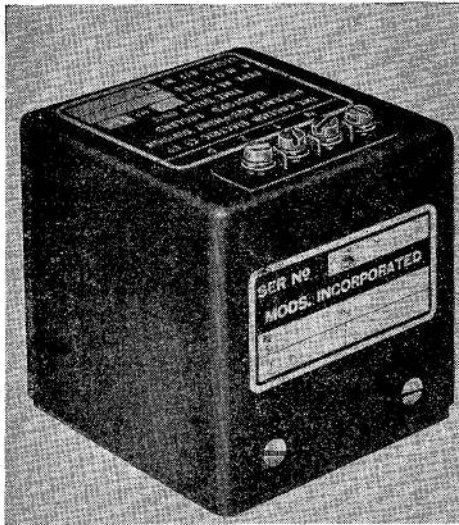

Fig. 1. Time delay unit, E.E. Type AE5630

Introduction

1. The time delay unit, English Electric, Type AE5630 provides a set time delay of between 0.5 to 6.0 seconds in the operation of a sealed relay on an input of 24 to 30 volts d.c. Each unit has a specified time delay.

DESCRIPTION

2. Components are housed within a black nylon cover and an aluminium-alloy base plate, see general view of unit, fig. 1. A flat surface is presented by each side of the unit except the top side through which the terminals protrude and to which the nameplate is affixed. The specific time delay of the unit is shown in seconds on the nameplate by a number separated from the type number by a strike, e.g. "Type AE5630/1" indicates a time delay of 1.0 second.

3. The base of the unit is an aluminium-alloy extrusion and houses four Zener diodes and two transistors fitted with Helsyn sleeves, see view of unit with cover removed, fig. 2. A bottom board assembly of bonded glass fabric is secured directly to the base by four fixing studs; two resistors and a 250 μ F capacitor are mounted on it. The spacer type heads of the studs are tapped 6 B.A. and form pillars which support a top plate assembly. A sealed relay and two potentiometers are mounted on the top plate assembly. The potentiometers are mounted as a pair and are secured in position by 8 B.A. round-head screws and nuts and the relay is fixed in

position by a stainless steel stiffnut and associated washers. The top plate assembly is secured to the fixing studs by two countersunk-head 6 B.A. screws and two further fixing studs whose heads are also tapped. A four-way terminal block is secured to the heads of the fixing studs of the top plate assembly by two fat cheese-head 4 B.A. screws, the terminals protrude through an aperture in the top side of the cover. Components are connected electrically by P.T.F.E. equipment wire through the lugs of the bottom board assembly. The wiring passes through a rubber grommet in the top plate assembly. Four 8 B.A. countersunk-head screws fix the cover to the base and the baseplate is secured by four 6 B.A. countersunk-head screws. Holes in the base plate align with the four 4 B.A. tapped mounting holes in the base.

4. The potentiometers are two 15000 ohms Painton types. The adjusting screw of each potentiometer is locked positively with Araldite "F".

5. The relay is a Type "F", C.P. Clare & Co. Ltd., sealed relay. The contacts of the relay are rated 3 amperes at 28 volts d.c.

OPERATION

6. On an input of 24 to 30 volts d.c. the unit provides a time delay of between 0.5 to 6 seconds in the operation of a sealed relay. The period of the time delay is governed by the settings of the potentiometers. The input, normally 28 volts d.c., is fed to a stabilized resistor-capacitor network which energizes a transistor network that causes the relay to operate. Referring to wiring schematic diagram, fig. 3, Zener diodes ZD1, ZD2 and ZD3 stabilize and hold the input constant. The settings of potentiometers P1 and P2 govern the charging rate of capacitor C1. When the capacitor is charged to the breakdown voltage of Zener diode ZD4, which is loaded by resistor R3, the Zener diode conducts and energizes transistors T1 and T2. The transistors cause the relay to operate. Capacitor C1 is short-circuited when the relay is energized and thus the unit is reset for the subsequent operation.

INSTALLATION

7. The unit can be installed in any attitude. Four 4 B.A. tapped holes are provided in the base for the purpose of mounting the unit. Electrical connections are made at the terminal block.

RESTRICTED

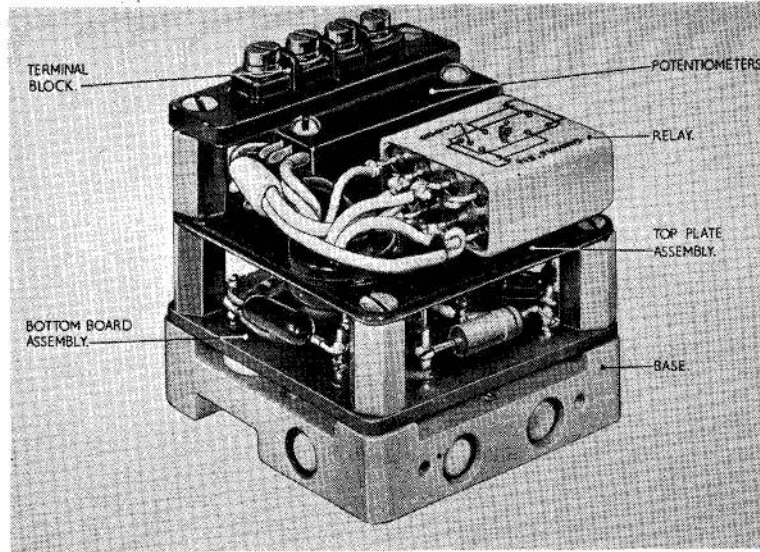

Fig. 2. View of unit with covers removed

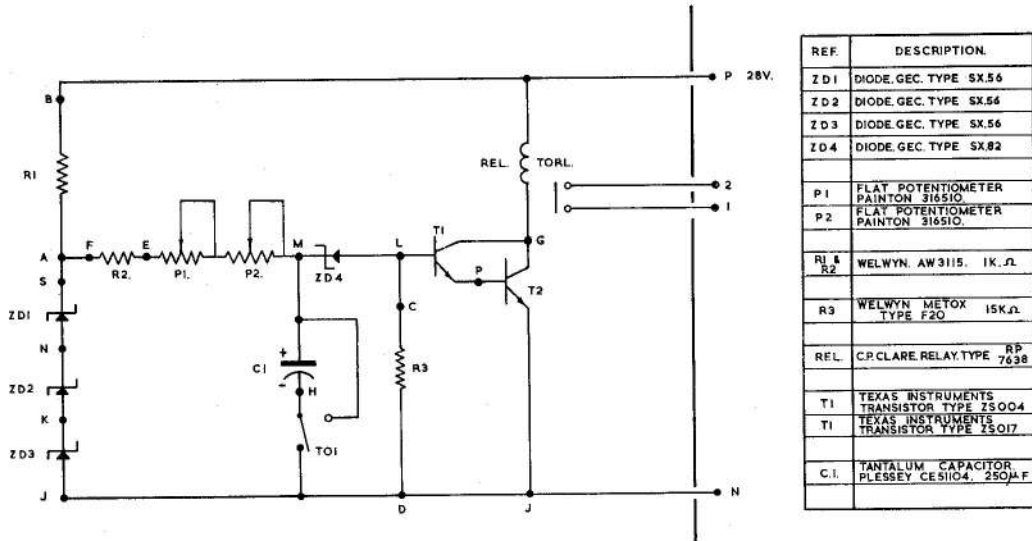

Fig. 3. Wiring schematic diagram

RESTRICTED

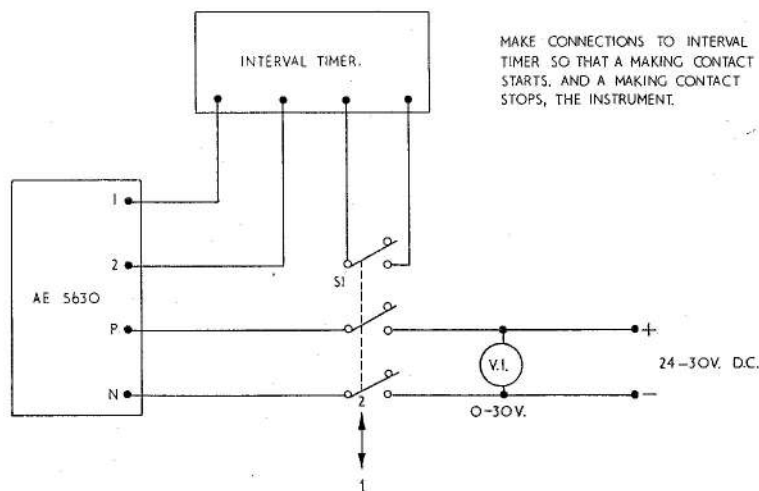

Fig. 4. Functional test circuit

SERVICING

8. When installed in the aircraft the unit should be inspected for the following:—

- (1) Security of mounting
- (2) Security of electrical connections
- (3) Signs of damage or corrosion

TESTING

Supply and meters

9. A 28 volts (nominal) d.c. supply, capable of variable control between 24 and 30 volts is required.

10. Precision grade meters are to be used. The d.c. line voltmeter must be capable of reading 30 volts \pm 0.3 per cent.

Functional test

11. (1) Connect unit to functional test circuit shown in fig. 4.
- (2) Select switch S1 to position 2 and adjust the supply so that V1 indicates 30 volts.

(3) Select switch S1 to position 1 and record time delay as indicated on the interval timer. Replace switch S1 to position 2 and reset timer.

(4) Repeat procedure of sub-paragraph (3) with V1 set to 27 and 24 volts and record time delay for each voltage.

(5) The recorded values should not exceed plus or minus 5 per cent of the specified figure for the unit.

Setting-up procedure

Note . . .

This procedure is not necessary if the functional test of the unit is satisfactory.

12. (1) Remove cover from unit.
- (2) Replace potentiometers with two new 15000 ohm Painton potentiometers, see diagram of connections, fig. 5.
- (3) Set potentiometers P1 and P2 to appropriate position shown in following table:—

Type No.		5630/1	5630/2	5630/3	5630/4	5630/5	5630/6
Specified time delay in seconds		1	2	3	4	5	6
Approximate settings for both potentiometers	Position	Fully c/w		About mid-way	About mid-way		Fully counter c/w
	Turns counter-clockwise	3	7	11	15	20	24

RESTRICTED

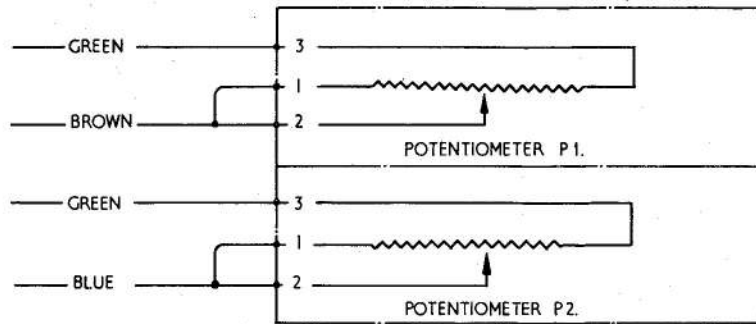

DIAGRAM OF POTENTIOMETER
CONNECTIONS.

Fig. 5. Diagram of potentiometer connections

(4) Connect unit to function test circuit shown in fig. 4.

(5) Select switch S1 to position 2 and adjust supply so that V1 indicates 27 ± 0 volts.

(6) Select switch S1 to position 1 and observe time delay as indicated on the interval timer. Replace switch S1 to position 2 and reset timers.

(7) If the time delay is higher or lower than the specified value for the unit adjust the potentiometers slowly in a clockwise or counter-clockwise rotation respectively, and repeat procedure from sub-paragraph (6) until the specified time delay is obtained.

Note . . .

For fine adjustment use one potentiometer.

(8) Positively lock adjusting screws of potentiometers using Araldite "F".

(9) Fit cover to unit.

Contact drop test

13. Connect a 28 volts (nominal) d.c. voltage supply to terminals P and N of unit and apply a d.c. voltage source to terminals 1 and 2 adjusting current flow to 3 amperes. Make and break relay contacts of unit 10 times by switching d.c. supply and then measure the millivolt drop across the contacts. The value should not exceed 100 millivolts.

Insulation test

14. Measure the leakage current using a 0-50 μ A industrial grade ammeter or multi-meter type 12889 with a 0.5 megohm ($\frac{1}{4}$ W) resistor in series with the positive probe as shown in fig. 6. Connect the test circuit (fig. 6) to a d.c. supply variable between zero and 28V. Increase the voltage gradually from zero to 28V. The leakage current should not exceed 1.4 μ A when this voltage is applied between:—

- (1) all terminals and frame.
- (2) terminal P and 1 and 2 shorted together.

Before removing test circuit decrease voltage gradually to zero. ▶

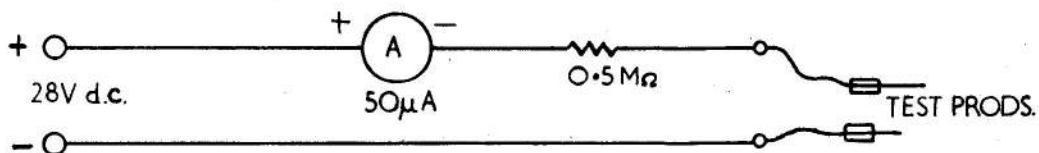
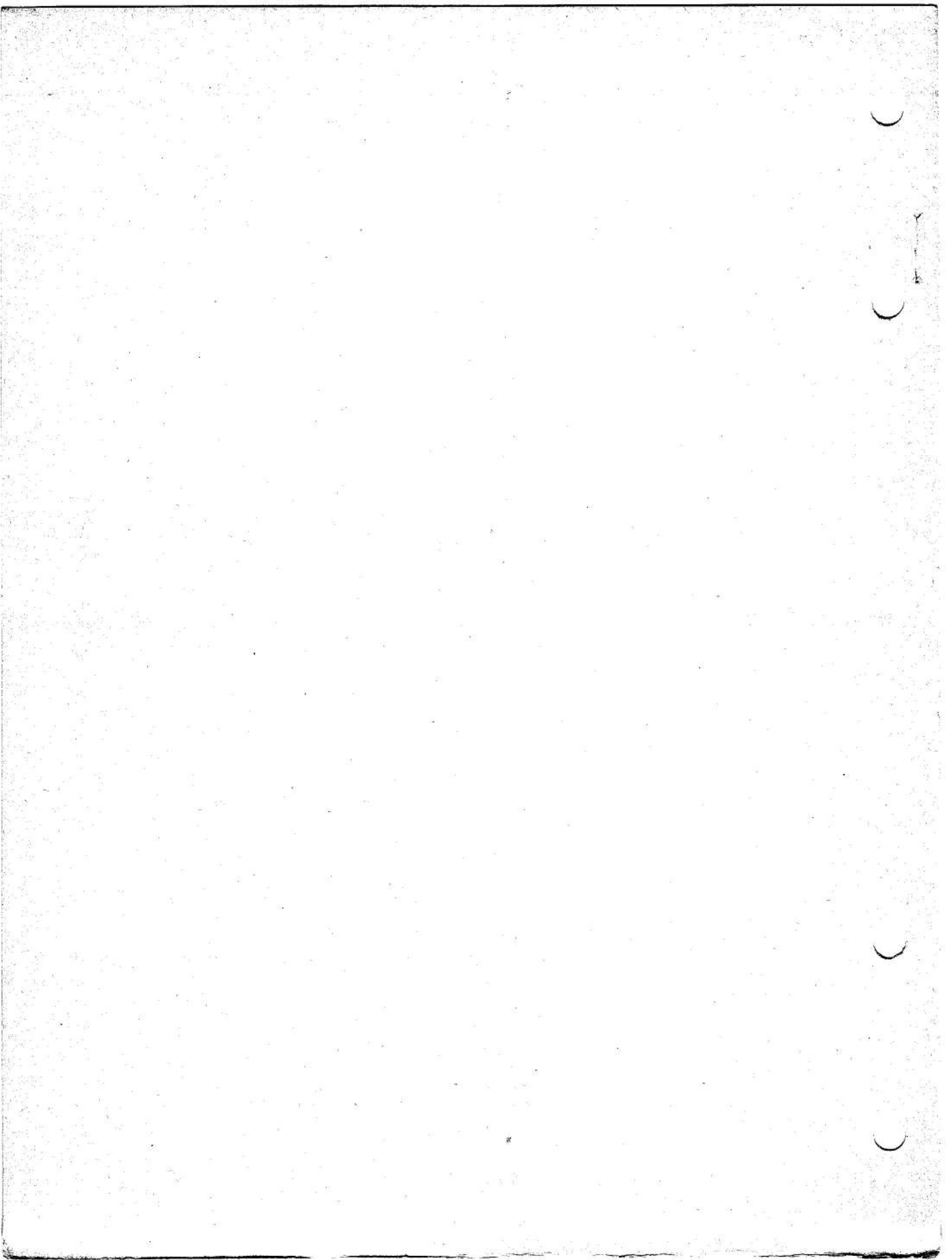

Fig. 6. Insulation test circuit

RESTRICTED



This file was downloaded
from the RTFM Library.
Link: www.scottbouch.com/rtfm
Please see site for usage terms,
and more aircraft documents.

