

*See AP 113D-0759-1 not held 'C'*

**Chapter 31**

**CONTROL PANEL, TYPE 47**  
(Frequency regulator)

**LIST OF CONTENTS**

	Para.		Para.
<i>Introduction</i> ... ..	1	<b>Testing</b>	
<b>Description</b>		<i>General</i> ... ..	12
<i>General</i> ... ..	2	<i>Compounding transformers characteristic</i>	13
<i>Frequency discriminator circuit</i> ... ..	5	<i>Pre-set reference</i> ... ..	14
<i>Magnetic amplifier</i> ... ..	6	<i>Magnetic amplifier characteristic</i> ... ..	15
<i>Compounding transformers</i> ... ..	7	<i>Regulation test</i> ... ..	16
<b>Operation</b> ... ..	8	<i>Insulation resistance tests</i> ... ..	17
<b>Servicing</b> ... ..	11		

**LIST OF ILLUSTRATIONS**

	Fig.		Fig.
<i>Control panel, Type 47</i> ... ..	1	<i>Magnetic amplifier test circuit</i> ... ..	5
<i>Wiring diagram</i> ... ..	2	<i>Magnetic amplifier control characteristic</i>	6
<i>View with cover removed</i> ... ..	3	<i>Compounding transformers test circuit</i> ... ..	7
<i>View with baseplate removed</i> ... ..	4	<i>Compounding transformers control characteristic</i> ... ..	8

**LEADING PARTICULARS**

<i>Control panel, Type 47</i> ... ..	Ref. No. 5UC/6927
<i>Control frequency</i> ... ..	400 c/s $\pm 1\frac{1}{2}$ per cent
<i>Adjustment</i> ... ..	$\pm 3$ per cent
<i>Weight</i> ... ..	11 $\frac{1}{2}$ lb. approx.

**RESTRICTED**

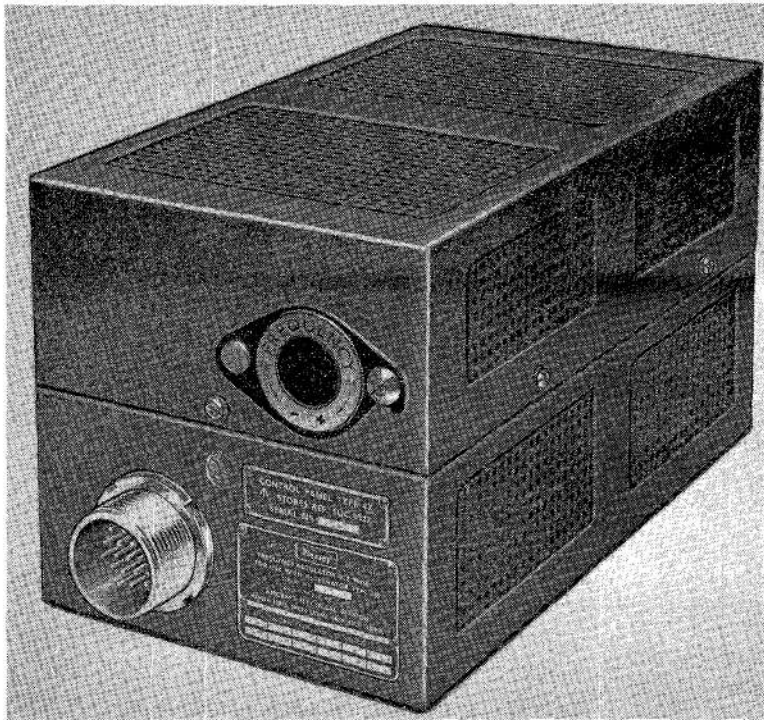

Fig. 1. Control panel, Type 47

### Introduction

1. The control panel, Type 47, is used in conjunction with a constant speed drive unit, to control the frequency of the a.c. generator, Type 165, at 400 c/s  $\pm 1\frac{1}{2}$  per cent; it is a component part of the Labinal generating system which is described in A.P.4343, Vol. 1, Sect. 2.

### DESCRIPTION

#### General

2. The control panel comprises a rectangular alloy single deck chassis, which forms a mounting platform for the various components of the unit. The side panels of the chassis are perforated to provide ventilation. The components mounted on top of the chassis are enclosed by a ventilated cover, and access to the components which are underslung is gained by removal of the baseplate. View of the chassis with the top cover and baseplate removed are shown in fig. 3 and 4.

3. The components fitted on top of the chassis comprise rectifier assembly MR1, the six diodes of which are mounted on cooling fins, two silicon bonded glass fabric tagboard

assemblies TB1 and TB2, transformers T1 and T2, magnetic amplifier MA and variable resistor RV1. The tagboard assembly TB1 contains the four diodes of rectifier MR2, the four diodes comprising rectifier MR3, the four diodes of rectifier MR4 and capacitors C5 and C6. The tagboard assembly TB2 contains resistors R1, R2, R3 and R4, and capacitors C1, C2, C3 and C4.

4. The components fitted to the underside of the chassis comprise compounding transformers TC1, TC2 and TC3, and inductors L1, L2 and L3. Electrical connection to the unit is made through a 19-pole UK-AN connector fitted at one end of the chassis.

#### Frequency discriminator circuit

5. The frequency discriminator circuit consists of two single-phase bridge arrangements of rectifiers MR3 and MR4 both supplied from the secondary winding of transformer T2, the primary winding of transformer T2 is connected to the generator busbars. The circuit containing MR3 is a high pass filter network comprising capacitors C1, C2, C3 and inductor L; the output from this circuit supplies a control winding of the magnetic

RESTRICTED

amplifier MA. The circuit containing MR4 supplies a polarizing winding of the magnetic amplifier, and is in opposition to the control winding. Variable resistor RV1 is connected in circuit with the polarizing winding to provide adjustment.

**Magnetic amplifier**

6. The magnetic amplifier consists of a single-phase bridge arrangement of rectifier MR2 in series with the amplifier main winding and supplied from the single-phase trans-

former T1. The d.c. output from the rectifier bridge is applied through the self excitation feedback winding to the series connected saturation windings of the compounding transformers. The control signal for this output is the output from the discriminator circuit applied to the control winding and polarizing winding. The control circuit is stabilized by the use of a transient feedback signal obtained from the rectified output of the compounding transformers secondary windings applied to the feedback winding.

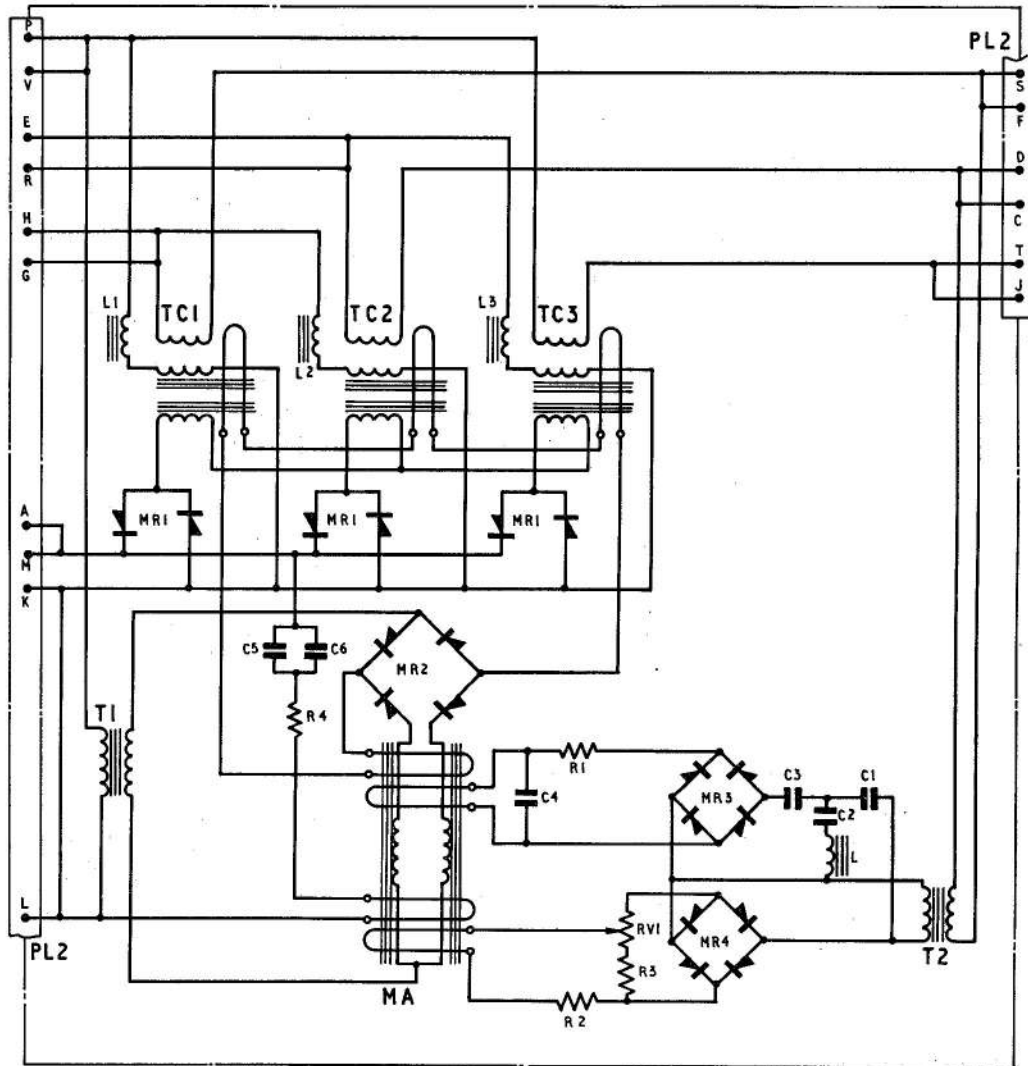

Fig. 2. Wiring diagram

**RESTRICTED**

### Compounding transformers

7. Compounding transformers TC1, TC2 and TC3 adjust the excitation current of the eddy current brake motor in the generator constant-speed unit to maintain equilibrium between the brake motor and generator

torques and to maintain the controlled frequency at the a.c. busbars. Each transformer has four windings a current winding and a voltage winding which form the primary side of the transformer, a secondary winding and a saturation winding. The

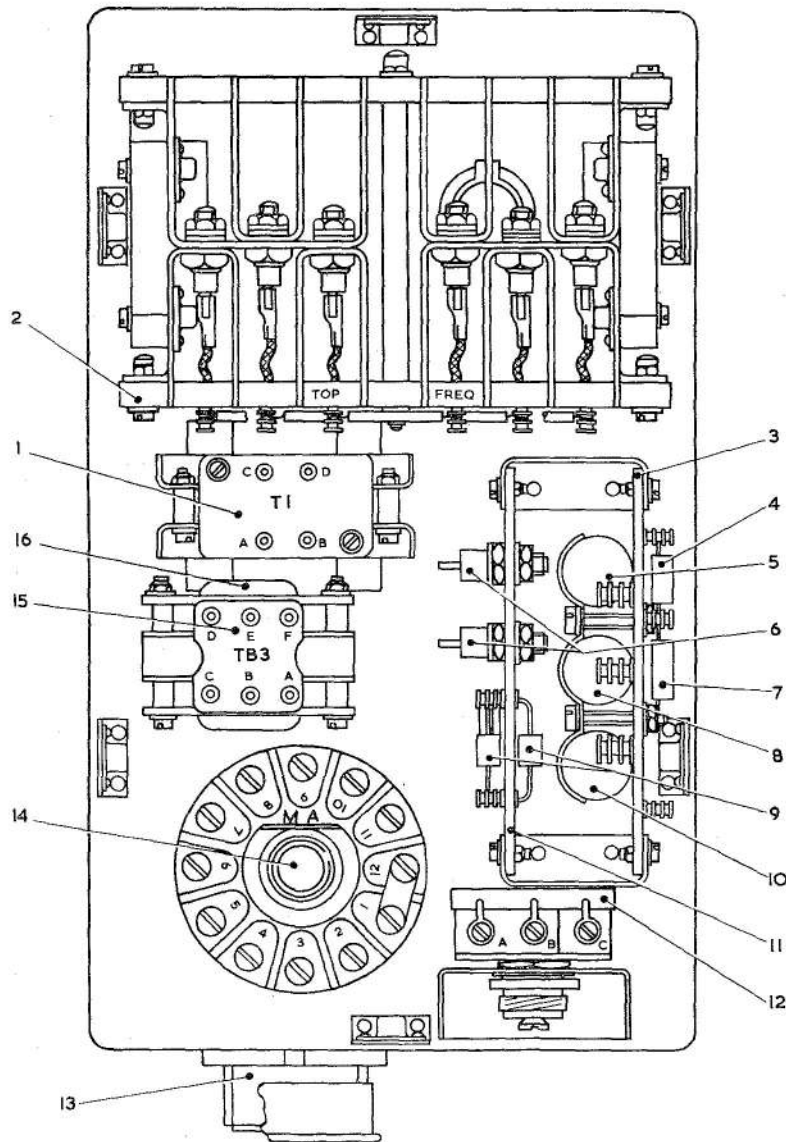

- |                                      |   |
|--------------------------------------|---|
| 1 TRANSFORMER T1                     | 9 RECTIFIERS MR3                          |
| 2 RECTIFIER AND COOLING FIN ASSEMBLY | 10 CAPACITOR C1                           |
| 3 TAGBOARD ASSEMBLY NO. 2            | 11 TAGBOARD ASSEMBLY NO. 1                |
| 4 RESISTOR R1                        | 12 VARIABLE RESISTOR RV1                  |
| 5 CAPACITOR C3                       | 13 CONNECTOR UK-AN-FIX-22-14-PX           |
| 6 RECTIFIERS MR2                     | 14 MAGNETIC AMPLIFIER                     |
| 7 RESISTOR R4                        | 15 TAGBOARD ASSEMBLY NO. 3                |
| 8 CAPACITOR C2                       | 16 TRANSFORMER T2 AND INDUCTOR L ASSEMBLY |

Fig. 3. View with cover removed

**RESTRICTED**

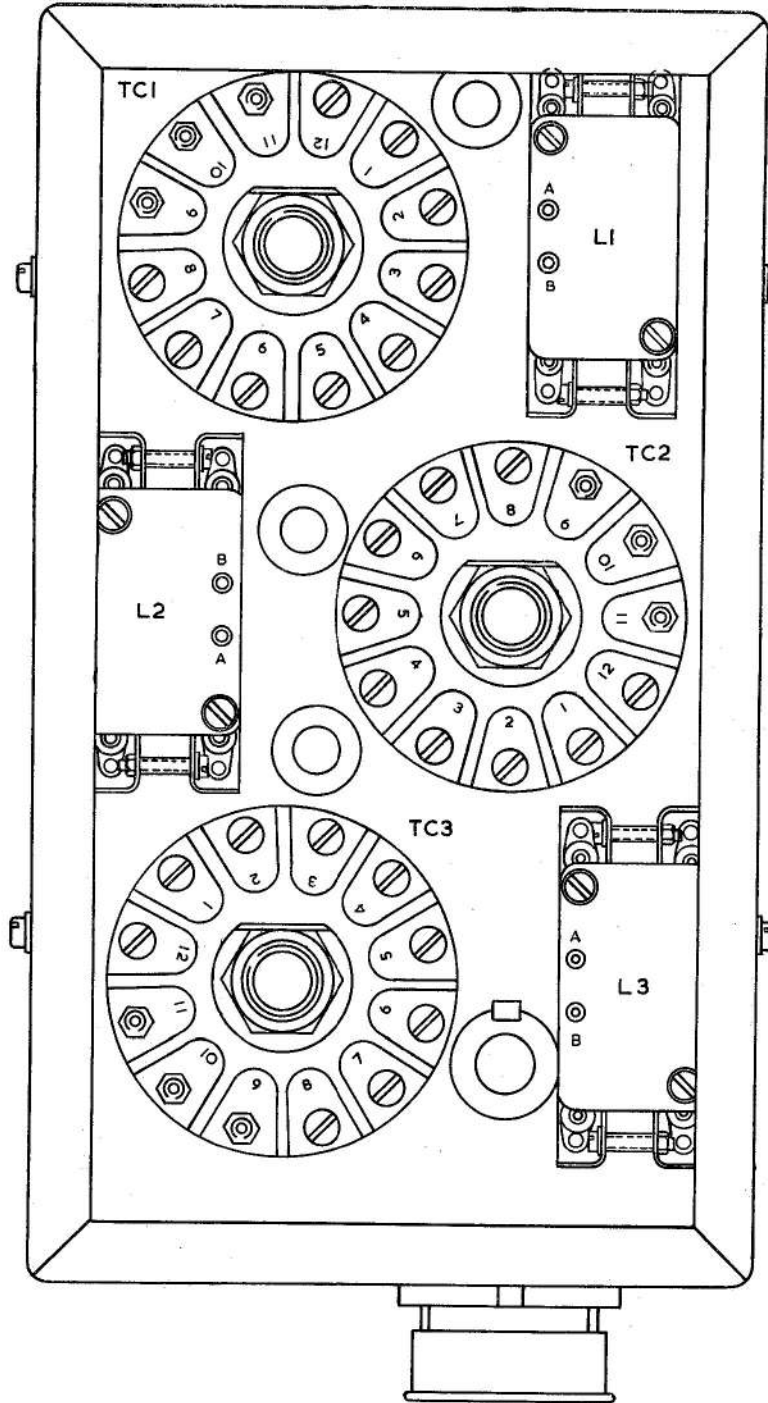

Fig. 4. View with baseplate removed

**RESTRICTED**

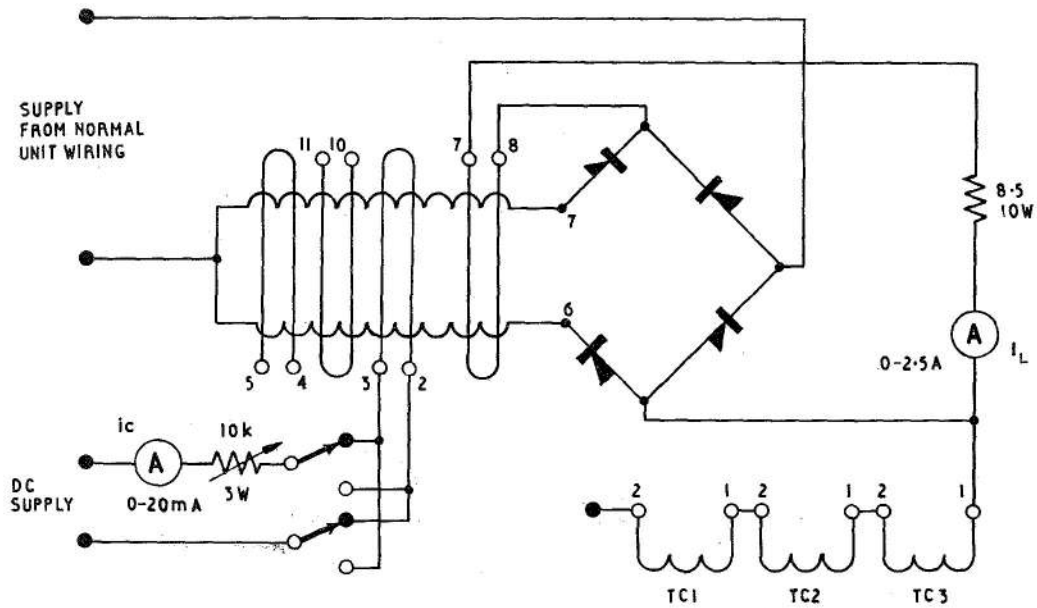

Fig. 5. Magnetic amplifier test circuit

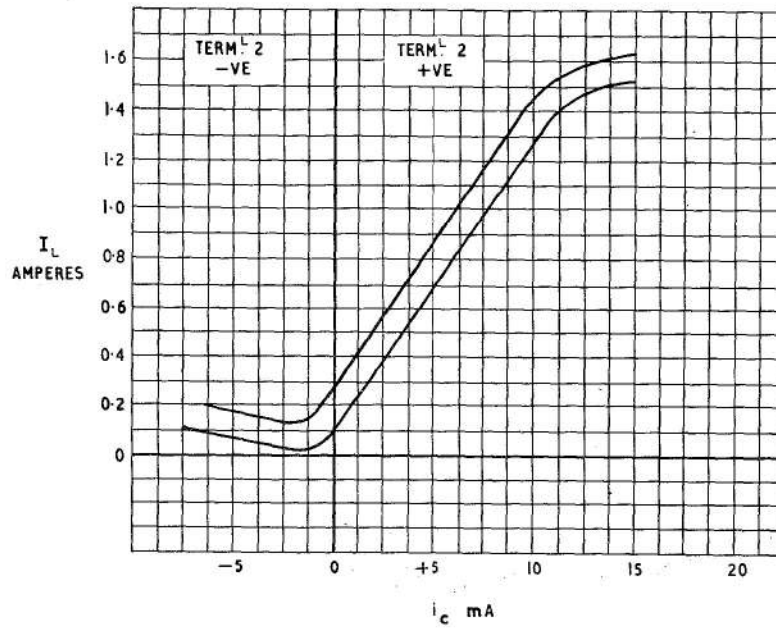

Fig. 6. Magnetic amplifier control characteristic

**RESTRICTED**

current windings are connected in series with each of the generator phase lines; the voltage winding of transformer TC1 is connected in series with an inductor between the input phase to transformer TC3 and the neutral point, the voltage windings of transformers TC2 and TC3 are connected in a similar manner to the input phases of transformers TC1 and TC2. The secondary winding output current is rectified by MR1 and applied to the eddy current brake motor field. The current in the saturation winding is controlled from the frequency discriminator circuit and adjust the saturation point of the transformer to maintain the frequency within the regulated limits.

### OPERATION

8. The generator speed and hence the frequency is regulated by controlling the slip of the eddy current brake motor, excitation current to the brake motor is provided by the secondary windings of the compounding transformers, rectified by MR1. The output of the secondary windings is dependent upon the load current delivered by the generator, and the direction and magnitude of the frequency error.

9. The generator torque is dependent upon its power output, and the brake motor torque is a function of its excitation current, therefore for all values of true power delivered by the generator there is a corresponding excitation current to the brake motor to adjust the torque so that no differential exists between the brake motor torque and the generator torque.

10. The frequency discriminator circuit detects any variation in frequency from the desired value and operates the control winding of the magnetic amplifier. The output current of the amplifier is supplied to the saturation winding of each compounding transformer, and changes rapidly when the frequency varies from 400 c/s. If frequency tends to increase saturation winding adjusts the compounding transformers so that a decrease in brake motor excitation occurs, resulting in a decrease in generator rotor speed. The inverse occurs if frequency tends to decrease.

### SERVICING

11. The control panel should be serviced in accordance with the relevant Servicing

Schedule. It should be inspected for signs of corrosion and damage to the cover, chassis, components and electrical connections. Collection of dust and other foreign matter should be blown out using a jet of dry clean compressed air. Access to the inside of the control panel is obtained by removal of the top cover and baseplate. No special instructions are required for dismantling the components from the chassis such dismantling should only be necessary when the components require to be renewed.

### TESTING

#### General

12. The power supplies required for the tests given in para. 13 to 15 should be equivalent to those used on the particular aircraft systems. For the test given in para. 16, the control panel should be connected to a test circuit using the generator and the voltage regulator with which it is normally associated when installed. The generator should be driven by a variable-speed test set, and its output should be connected to a 3-phase, 4-wire, star-connected load bank adjustable for 0 to 6kW in 1kW steps.

#### Compounding transformers characteristic

13. Connect the control panel to the test circuit as shown in fig. 7. Isolate the saturation windings by disconnecting the wiring from terminal 9 of the magnetic amplifier. Ensure that the input supply voltage, frequency and phase rotation is correct. Switch on the load in 1kW increments over the range 0 to 5kW taking readings of the load current and the excitation current at each step. The characteristic obtained should be within the limits specified in fig. 8. Switch off the supply and disconnect the load.

#### Note . . .

*The period when the 5kW load is on should not exceed 2 min.*

#### Pre-set reference

14. Reconnect the wiring to terminal 9 of the magnetic amplifier. With the circuit connected as for the test given in para. 13, but with the load disconnected, switch on the supply. Rotate variable resistor RV1, and check that the excitation current  $I_{ex}$  increases for clockwise rotation and decreases for counter-clockwise rotation. Switch off the supply and disconnect the control panel from the test circuit.

**RESTRICTED**

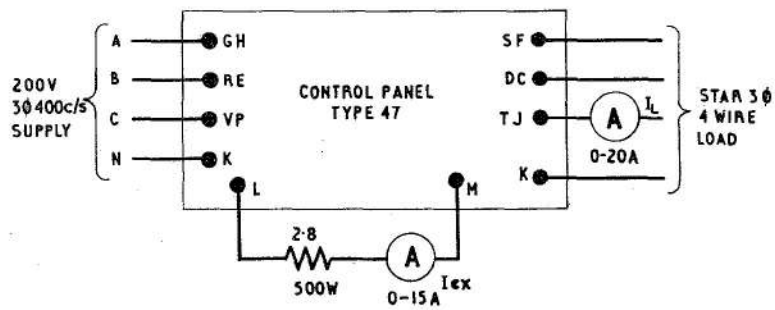

Fig. 7. Compounding transformers test circuit

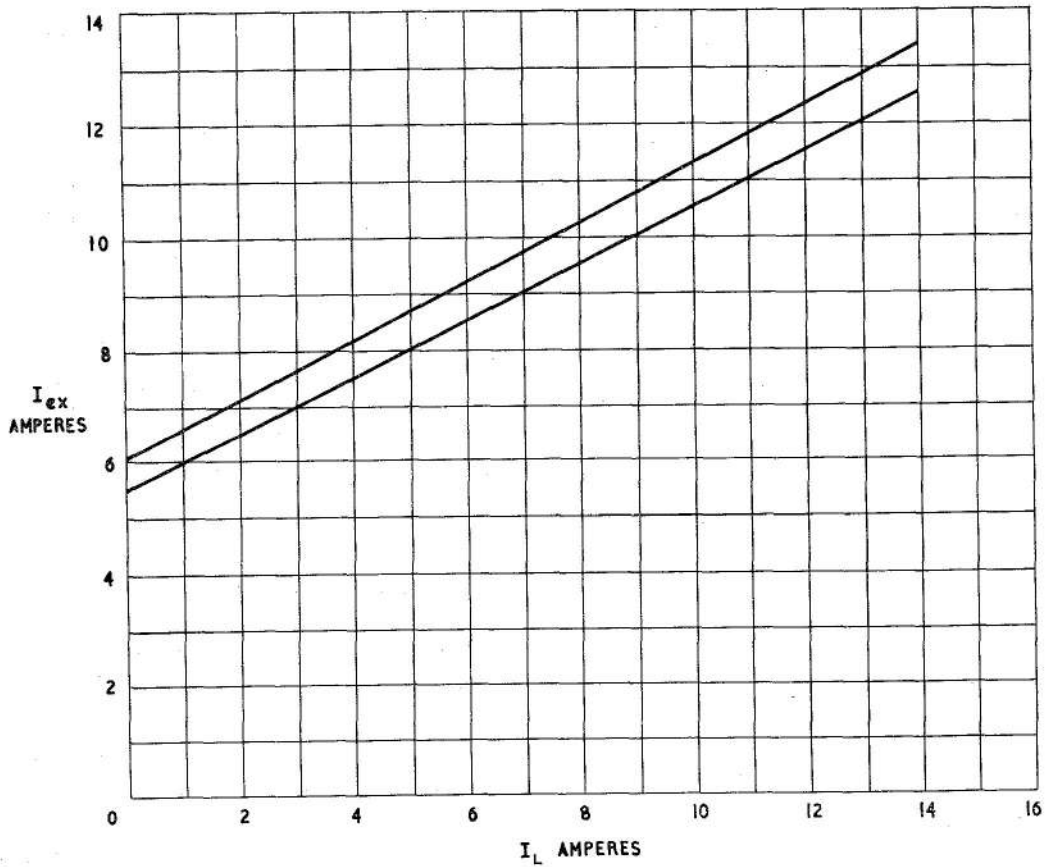

Fig. 8. Compounding transformers control characteristic

**RESTRICTED**

**Magnetic amplifier characteristic**

15. Disconnect the wiring from terminals 2, 3, 4, 5, 9, 10 and 11. Connect the control panel to the test circuit as shown in fig. 5. Connect a 15 max. d.c. supply through the variable resistor, ammeter and changeover switch to terminals 2 and 3. Switch on the a.c. supply. Vary the control winding current  $I_c$  over the range shown by the graph (fig. 6), in at least five increments, taking readings of output and control current at each step. The characteristic obtained should be within the limits specified in fig. 6. Disconnect the supplies and reconnect the internal wiring as per the circuit diagram fig. 2.

**Note . . .**

*The d.c. supply should not be disconnected when the control current is zero.*

**Regulation test**

16. Connect the control panel in circuit with its associated system components. Run the generator at 6000 rev/min. on no load, and check that the phase rotation is correct. Adjust the output frequency to 396 c/s by means of the variable resistor RV1 after ensuring that adjustment over the range 375

to 400 c/s is obtainable. Run the generator over the following input speed ranges at the given load conditions. The controlled frequency should remain within the limits of 394 to 406 c/s.

Load	Speed range
1kW, u.p.f.	4700-8000-4700
1kVA, 0.8 p.f. lag	4700-8000-4700
2kW, u.p.f.	4700-8000-4700
2kVA, 0.8 p.f. lag	4700-8000-4700
3kW, u.p.f.	4700-8000-4700
3kVA, 0.8 p.f. lag	4700-8000-4700
4kW, u.p.f.	5500-8000-5500
4kVA, 0.8 p.f. lag	5500-8000-5500

**Insulation resistance test**

17. Check the insulation resistance between pins K, L, A and M on the UK-AN connector and frame using a 250V insulation resistance tester. Check the insulation resistance between all other pins of the UK-AN connector and the frame using a 500V insulation resistance tester. The minimum permissible reading obtained for each test should be not less than 5 megohms.

**RESTRICTED**

1000

( )

( )

( )

This file was downloaded  
from the RTFM Library.  
Link: [www.scottbouch.com/rtfm](http://www.scottbouch.com/rtfm)

Please see site for usage terms,  
and more aircraft documents.

