

Now 113D-0786-1

**Chapter 32**  
**CONTROL PANEL, TYPE 48, No. 2**

**LIST OF CONTENTS**

	Para.		Para.
<i>Introduction</i> ... ..	1	<i>Over-speed protection circuit</i> ... ..	7
<b>Description</b>		<b>Servicing</b>	
<i>General</i> ... ..	2	<i>General</i> ... ..	8
<i>Clutch control circuit</i> ... ..	4	<i>Testing</i> ... ..	9
<i>Over-speed protection circuit</i> ... ..	5	<i>Gear change</i> ... ..	10
<b>Operation</b>		<i>Over-speed protection</i> ... ..	11
<i>Clutch control circuit</i> ... ..	6	<i>Insulation resistance</i> ... ..	12

**LIST OF ILLUSTRATIONS**

	Fig.		Fig.
<i>Control panel, Type 48, No. 2</i> ... ..	1	<i>Circuit diagram</i> ... ..	4
<i>View showing layout of components</i> ... ..	2	<i>Test circuit diagram</i> ... ..	5
<i>Filter circuit characteristic curve</i> ... ..	3		

**LEADING PARTICULARS**

*Control panel, Type 48, No. 2* ... .. Ref. No. 5UC/7307

**RESTRICTED**

## Introduction

1. The control panel, Type 48, No. 2 is used in conjunction with the Plessey automatic two-speed gearbox and the a.c. generator, Type 165. It is designed to control the selected points in the engine speed range at which the two-speed gearbox is to be operated.

## DESCRIPTION

### General

2. The control panel comprises an alloy box which contains the various components of the unit, access is gained by removal of the top cover. The inductors L1, L2 and L3, the transformer assembly and the capacitor encapsulation comprising capacitors C1, C2, C3, C4, C5, C7, C8 and C9 are located in the base of the box; the remaining components are mounted on a glass fabric tagboard (TB1) which is fitted on four lugs and suspended over the lower components. The components fitted on the tagboard TB1 comprise thermistors TH1 and TH2, capacitors C6 and C10, transistors VT1 and VT2, resistors R1, R2, R3, R4 and R5, rectifiers MR1, MR2/1 and MR2/2, and Zener diodes Z1 and Z2. Electrical connection to the unit is made through a Type UK-AN-FIX-14S 6-pole connector.

3. The unit contains two circuits, a solenoid-clutch control circuit and an over-speed protection circuit, each supplied from separate secondary windings of transformer T1. The primary winding of transformer T1 is connected to the output of the heteropolar inductor type generator, which together with a solenoid clutch, forms part of the two-speed gearbox.

### Clutch control circuit

4. The clutch control circuit functions to control the power switching of the clutch solenoid which must be de-energized for gearbox input speeds greater than approx. 5050 rev/min., and re-energized when the speed decreases to approx. 4950 rev/min. The circuit consists of a double section low pass filter network comprising inductors L1 and L2, and capacitors C1A, C1B, C3, C4 and C5 which functions as a frequency sensing circuit. The output from this circuit is applied to the solenoid switching circuit comprising resistors R1 and R2, rectifier MR1, capacitor C6, Zener diodes Z2, thermistor TH1 and transistor VT1. The emitter and collector connections of transistor VT1 are connected respectively to the 28V d.c. supply and to the solenoid clutch coil in the two-speed gearbox.



Fig. 1. Control panel, Type 48, No. 2

**RESTRICTED**

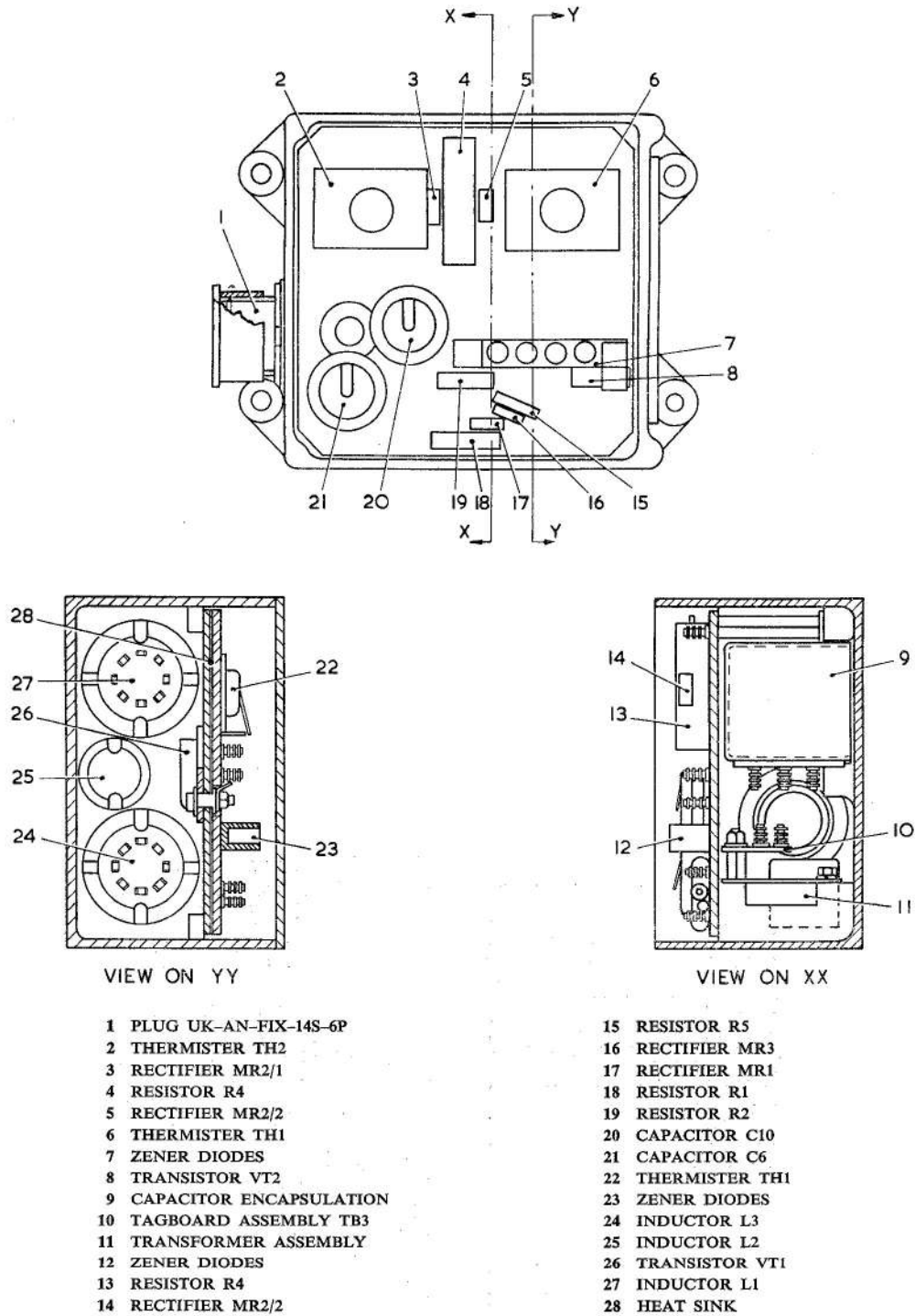

Fig. 2. View showing layout of components

**RESTRICTED**

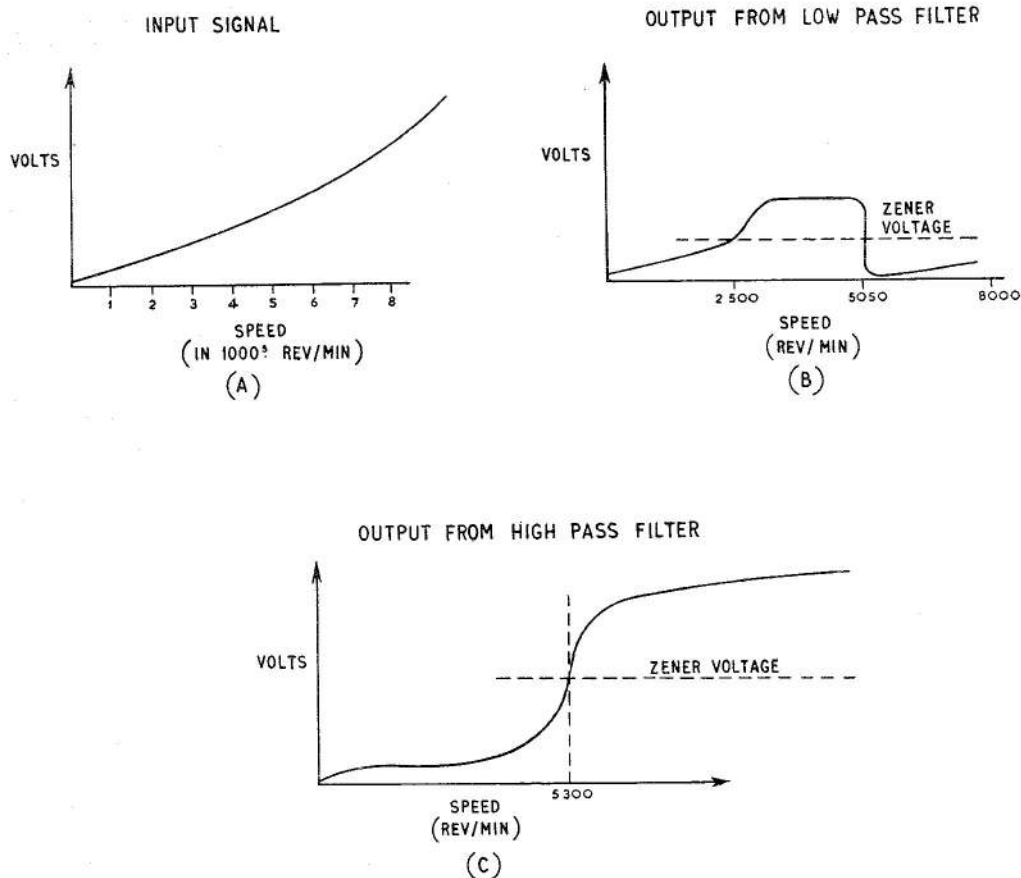

Fig. 3. Filter circuit characteristic curves

#### Over-speed protection circuit

5. The over-speed protection circuit is designed to ensure that the gearbox reverts to the 1:1 ratio if the input speed exceeds approx. 5300 rev/min. The circuit consists of a single section high pass filter network comprising inductor L3 and capacitors C7, C8 and C9 which functions as a frequency sensing circuit. The output from this circuit is applied to the switching circuit comprising resistors R4 and R5, rectifiers MR2/1, MR2/2 and MR3, capacitor C10, Zener diode Z1, thermistor TH1 and transistor VT2.

#### OPERATION

##### Clutch control circuit

6. With an increasing gearbox speed the input signal to the low pass filter network increases as shown by the graph fig. 3A, when the gearbox speed is increased to approx. 2500 rev/min. the output from the filter,

shown by the graph fig. 3B, causes the Zener diode Z2 to breakdown and current flows through the base/emitter circuit of transistor VT1. The transistor VT1 is switched to the on condition, and the clutch coil current flows through the base/collector circuit thus energizing the gearbox clutch solenoid. When the clutch solenoid is energized the gearbox operates in the stepped-up 1:62:1 ratio. When the gearbox speed is increased to 5050 rev/min. the output from the filter falls rapidly, transistor VT1 is switched to the off condition, thereby de-energizing the clutch solenoid. The gearbox reverts to the 1:1 ratio. The circuit is designed so that the gear change point occurs at 5050 rev/min. with an increasing drive speed, and at  $5050 - 100 \pm 25$  rev/min. with an increasing drive speed; this is to prevent hunting of the system due to normal engine speed variations at the change point.

**RESTRICTED**

**Over-speed protection circuit**

7. If the clutch control circuit fails to switch off, and the speed increases in excess of 5300 rev/min., the output from the high pass filter circuit, shown by the graph fig. 3C, causes Zener diode ZD2 to break down, thus transistor VT2 is switched to the on condition. The 28V d.c. supply circuit from pin F through transistor VT1 and transistor VT2 to pin D is then made to the operating coil of a relay within a Protection unit. The relay operates and breaks the negative return from the clutch coil circuit, the clutch coil becomes de-energized and the gearbox reverts to the 1:1 ratio.

**SERVICING**

**General**

8. The control panel should be serviced in accordance with the relevant Servicing Schedule. All components should be examined for signs of damage, corrosion and deterioration, and for security of attachment. ◀ If the top cover or side cover plate is removed, the surfaces should be cleaned and the covers resealed as follows:

- (1) Clean all mating surfaces and treat the contact surfaces of the cover, the

cover plate and the box with Primer MS.602 (Ref. No. 33C/1647), and allow two hours to dry.

- (2) Apply a thin layer of Silastomer 9161 mixed with 3 per cent by weight of Catalyst N.9162.

- (3) Fit the cover and the cover plate to the box immediately and screw down. ▶

**Testing**

9. Connect the control panel to the test circuit as shown in fig. 5. The tests should be performed using a Plessey two-speed gearbox (Ref. No. 5UA/7184) driven by a suitable variable speed test set. The relays incorporated in the test circuit for switching the indicating lamp should be designed for operation from a 24V d.c. supply and should have an operating coil resistance of approx. 250 ohms. Before commencing tests remove the side cover plate to gain access to the adjusting screws for inductors L1 and L3.

**Gear change**

- 10. (1) Rotate the screw controlling the air gap for inductor L1 fully clockwise.
- (2) Obtain a drive speed of  $5050 \pm 20$  rev/min.

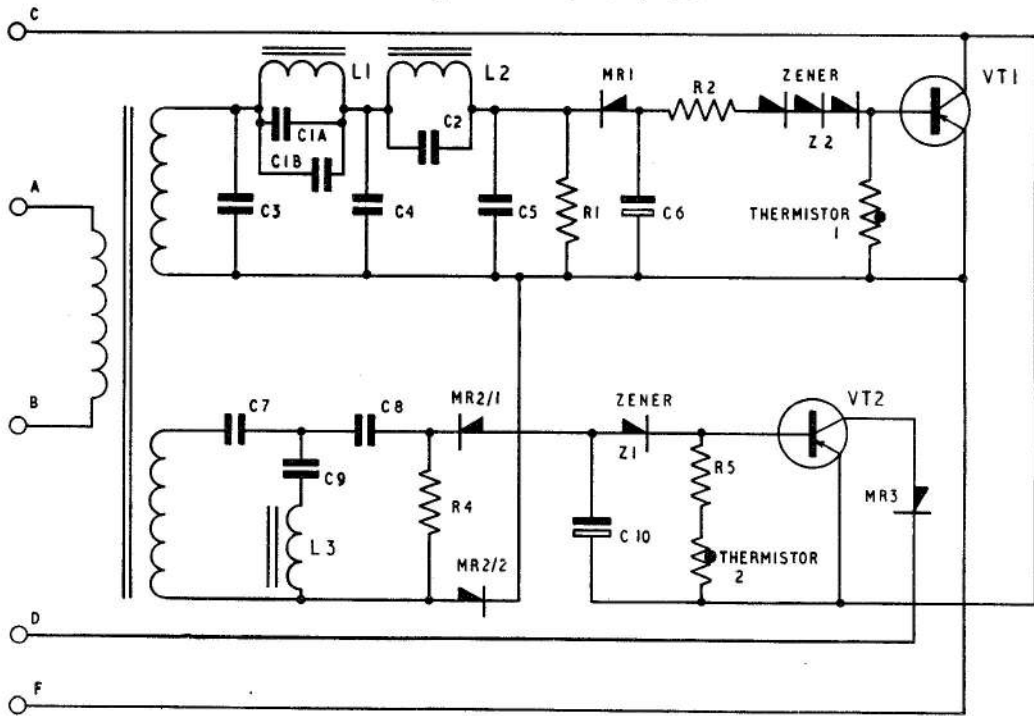

Fig. 4. Circuit diagram

**RESTRICTED**

- (3) Rotate the adjusting screw for L1 until lamp 1 is illuminated.
- (4) Check the operating point by decreasing the speed and then increasing until lamp 1 is again illuminated.
- (5) Note the speed at the change point, and readjust L1 as necessary to obtain the correct change point.
- (6) Decrease the speed and check that the lamp 1 is extinguished at a speed of  $100 \pm 25$  rev/min. below the gear change operating point.

#### Over-speed protection

11. (1) Rotate the screw controlling the air gap for inductor L3 fully clockwise.
- (2) Connect a shorting link between pins C and F, to simulate electrical gear change failure.
- (3) Obtain a drive speed of  $5300 \pm 20$  rev/min.

- (4) Rotate the adjusting screw for L3 until lamp 3 is illuminated.
- (5) Check the operating point by decreasing speed and then increasing until lamp 3 is again illuminated.
- (6) Note the speed at the change point and readjust L3 as necessary to obtain the correct change point.

#### Insulation resistance

12. Check the insulation resistance between each pin on the UK-AN connector and the frame, using a 250V insulation resistance tester. The reading obtained should exceed 5 megohms.

#### Note . . .

*Under no circumstances should an insulation resistance tester with a voltage exceeding 250V be used.*

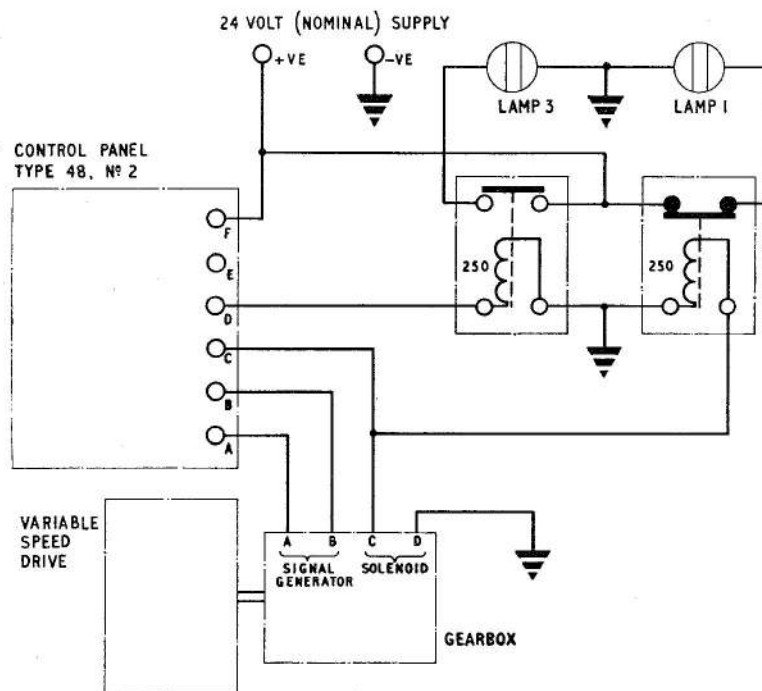

Fig. 5. Test circuit diagram

RESTRICTED

This file was downloaded  
from the RTFM Library.  
Link: [www.scottbouch.com/rtfm](http://www.scottbouch.com/rtfm)

Please see site for usage terms,  
and more aircraft documents.

