

Chapter 33
PROTECTION CONTROL UNIT, TYPE 2Y

LIST OF CONTENTS

	<i>Para.</i>		<i>Para.</i>
<i>Introduction</i>	1	<i>Over-voltage conditions</i>	9
Description		<i>Under-frequency conditions</i>	10
<i>General</i>	2	Servicing	
<i>Voltage control panel</i>	3	<i>General</i>	11
<i>Under-voltage circuit</i>	4	<i>Testing</i>	12
<i>Over-voltage circuit</i>	5	<i>Voltage control panel</i>	13
<i>Under-frequency control panel</i>	6	<i>Under-frequency control panel</i>	15
Operation		<i>Unit assembled</i>	16
<i>Normal conditions</i>	7	<i>Continuity test</i>	17
<i>Under-voltage conditions</i>	8	<i>Insulation resistance test</i>	18

LIST OF ILLUSTRATIONS

	<i>Fig.</i>		<i>Fig.</i>
<i>Protection control unit, Type 2Y</i>	1	<i>Voltage control panel test circuit diagram</i>	7
<i>Voltage control panel</i>	2	<i>Over-voltage circuit time delay characteristics</i>	8
<i>Under-frequency control panel</i>	3	<i>Under-frequency panel test circuit diagram</i>	9
<i>Circuit diagram of unit assembled</i>	4	<i>Unit test circuit diagram</i>	10
<i>Circuit diagram of voltage control panel</i>	5	<i>Circuit diagram, plug-socket connections</i>	11
<i>Circuit diagram of under-frequency panel</i>	6		

LEADING PARTICULARS

<i>Protection control unit, Type 2Y</i>	Ref. No. 5UC/6936
<i>Supply voltage phase/line</i>	3-phase, 120-208 volts
<i>Supply frequency</i>	400 c/s
<i>Weight</i>	2½ lb.

RESTRICTED

Introduction

1. The protection control unit, Type 2Y is used in a constant frequency a.c. generator system; it is designed to automatically connect the generator to the aircraft busbars and to provide protection against under-frequency, over-voltage, under-voltage and out-of-balance phase voltage faults.

DESCRIPTION

General

2. The components of the unit are housed within an alloy box, access is obtained by removal of the top cover. The unit contains two assemblies, a voltage control panel and an under frequency panel, which are mounted on separate supports. The electrical connection to each assembly within the unit is made through miniature five-way plugs and sockets, connections to the external circuit are made through a Type UK-AN-22-19P connector fitted at one end of the box. Four feet are provided at the base for mounting the unit to the airframe. The physical layout of the various components comprising the two assemblies is shown in fig. 2 and 3.

Voltage control panel

3. The function of the control panel may be divided into three sections as follows.

(1) The control, in conjunction with the under frequency unit, of the supply to the main contactor under normal operating conditions.

(2) The control of the supplies to the main contactor and lock-out relay RL6 in the event of under-voltage, over-voltage or out-of-balance phase voltage conditions. The main contactor is opened removing the generator from the busbars, and the generator field is de-energized by the operation of RL6.

Under-voltage circuit

4. The under-voltage protection circuit consists of relay RL2, a three-phase half-wave rectifier MR1, a single-phase bridge rectifier MR2, resistors R4, R5, R6, R7 and R8, and variable resistors RV3 and RV4. The relay RL2 has two differential coils A and B, the ampere turns produced by coil B being in opposition to that of coil A. Coil B is

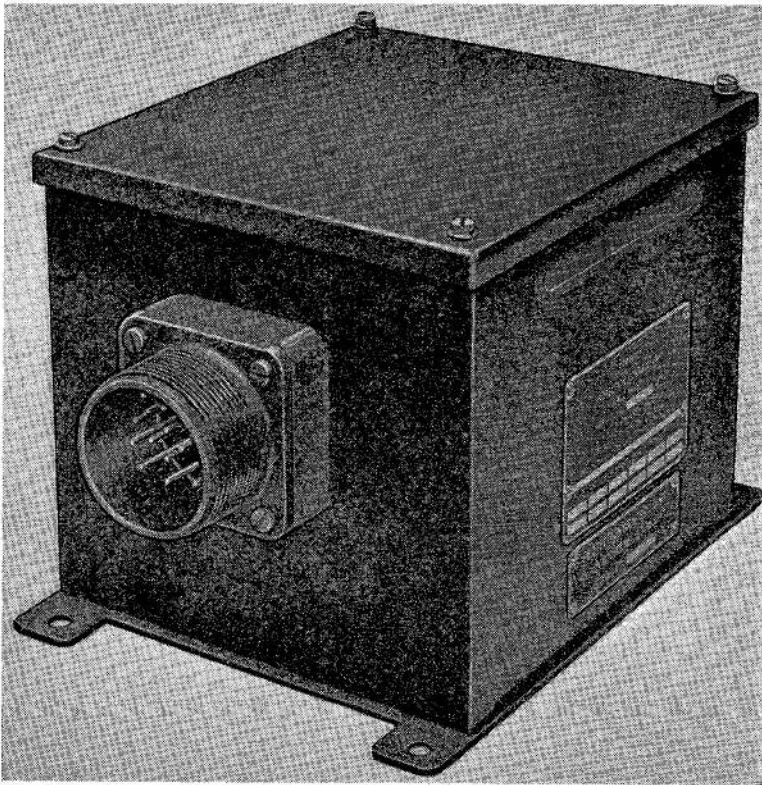

Fig. 1. Protection control unit, Type 2Y

RESTRICTED

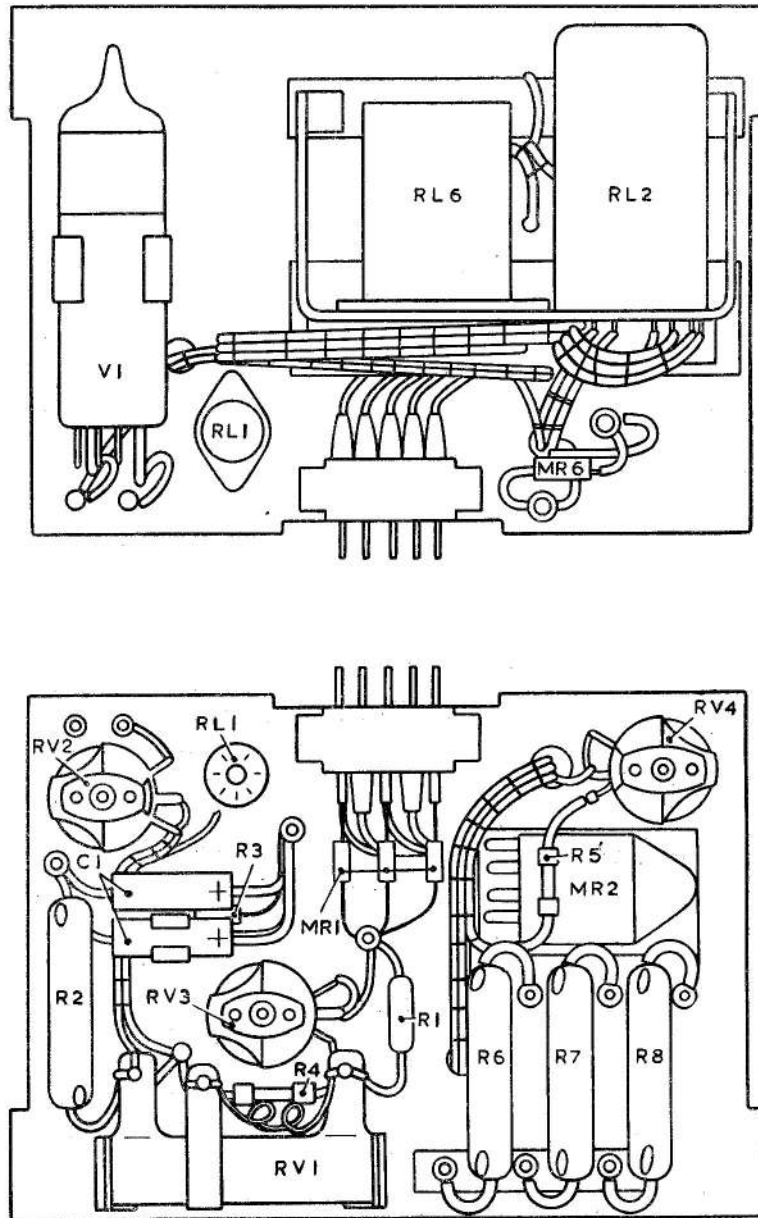

Fig. 2. Voltage control panel

connected between the generator neutral and an artificial neutral created by the equal resistors R6, R7 and R8 through the single-phase bridge rectifier MR2, thus the voltage across coil B will be proportional to the unbalance of the single-phase voltages. Coil A energizes and de-energizes the relay for

normal operation, coil B causes the relay to change over to the de-energized position when the unbalanced voltage exceeds a preset limit.

Over-voltage circuit

5. The components of the over voltage circuit comprise a potentiometer network

RESTRICTED

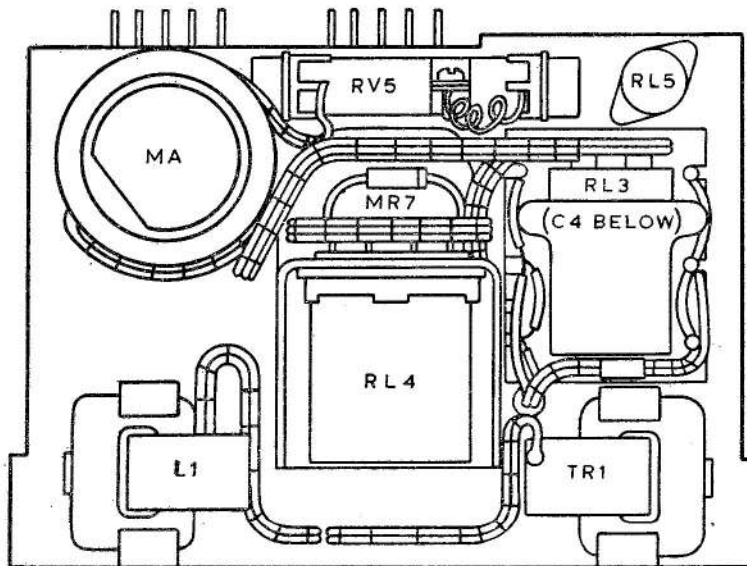
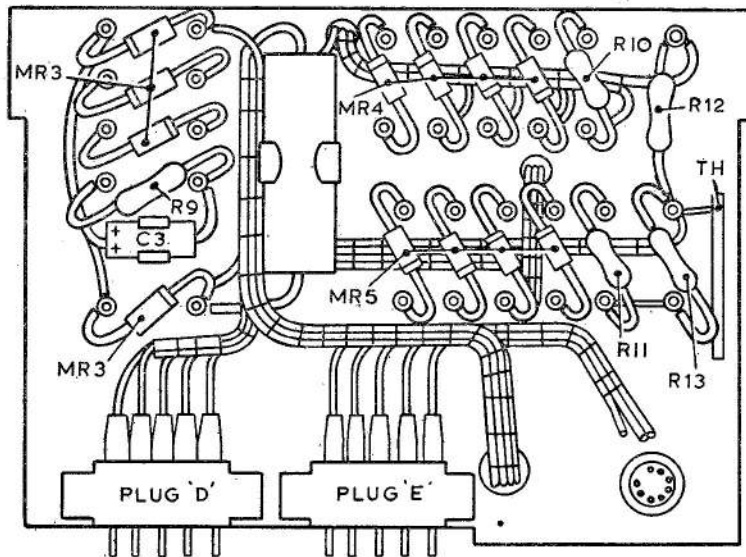

Fig. 3. Under-frequency control panel

consisting of resistors R1 and R2, and variable resistor RV1, a voltage reference diode V1, variable resistor RV2 and relay RL1. The operation of the relay is retarded by the resistor/capacitor circuit of resistor R3 and capacitor C1 in parallel with the relay coil. Variable resistors RV1 and RV2 are provided for adjustment of the voltage level and time delay of the circuit respectively.

Under-frequency control panel

6. The function of the under-frequency panel is the control, in conjunction with the under-voltage circuit of the supply to the main contactor. The circuit consists of two single phase bridge arrangements of rectifiers MR3 and MR4, both supplied from the auto-transformer TR1, a magnetic amplifier MA and a relay RL3. The circuit containing MR3

RESTRICTED

is a low pass filter network comprising capacitor C2 and inductor L1, the output of this circuit supplies the control winding of the magnetic amplifier. The circuit containing MR4 supplies the polarizing winding of the magnetic amplifier. The connection of the windings is such that the ampere turns produced by both windings are in normal opposition. The supply to the main winding of the magnetic amplifier is through the auto-transformer TR1, the output is rectified by MR5 and applied to the coil of relay RL3.

OPERATION

Normal conditions

7. Under conditions of normal operation the supply to the main contactor which, when energized, connects the generator to the

busbars is dependent upon (a) the function of the under-voltage circuit and (b) the function of the under-frequency circuit. The operation of these circuits is described in detail in paragraphs 8 and 10. With an increasing generator voltage the contact of relay RL2 on the voltage control panel changes over when the phase voltages are equally increased to 112 volts, the supply to coil A of RL2 being obtained from the average of the single-phase voltages of the rectifier MR1 through resistors RV3 and R4. With an increasing frequency the contacts of RL3 close when the frequency is increased to 380 c/s. The operation, under these conditions, of relays RL2 and RL3 connect the 28V d.c. supply to the operating coil of RL5 which changes over to supply 28V d.c. to the

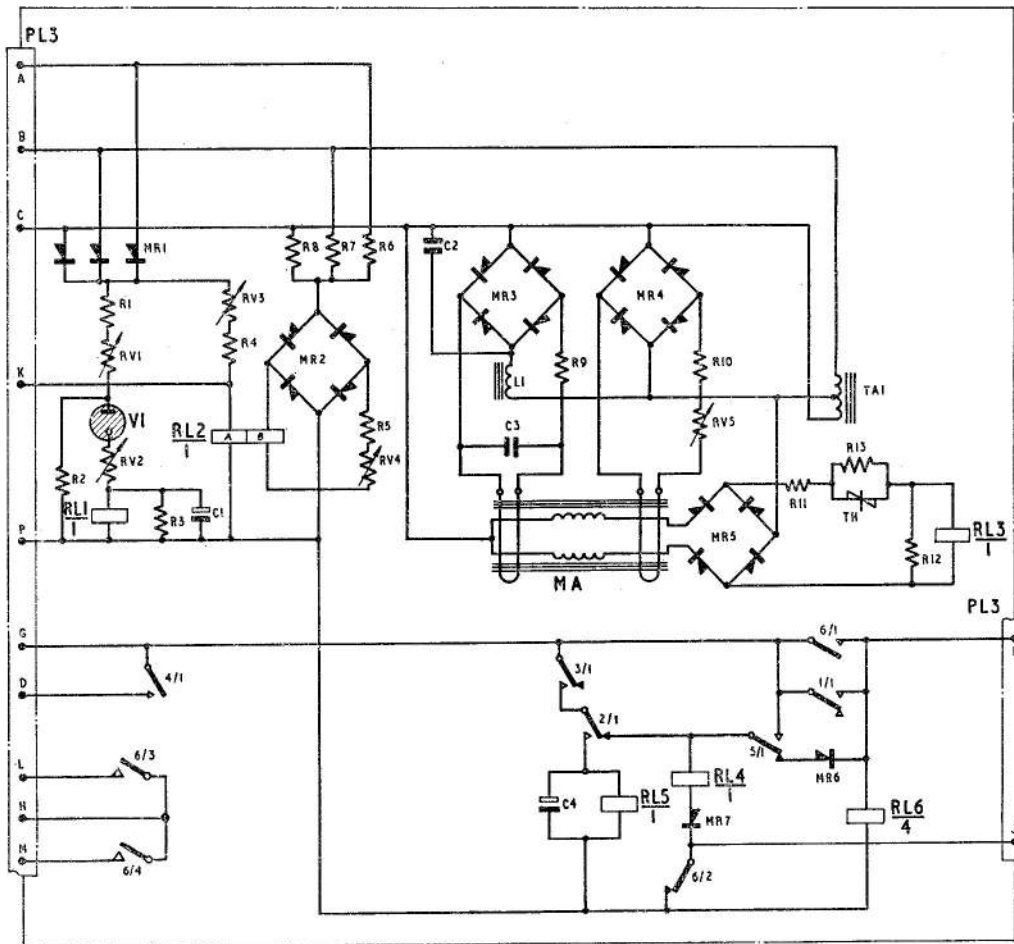

Fig. 4. Circuit diagram of unit assembly

RESTRICTED

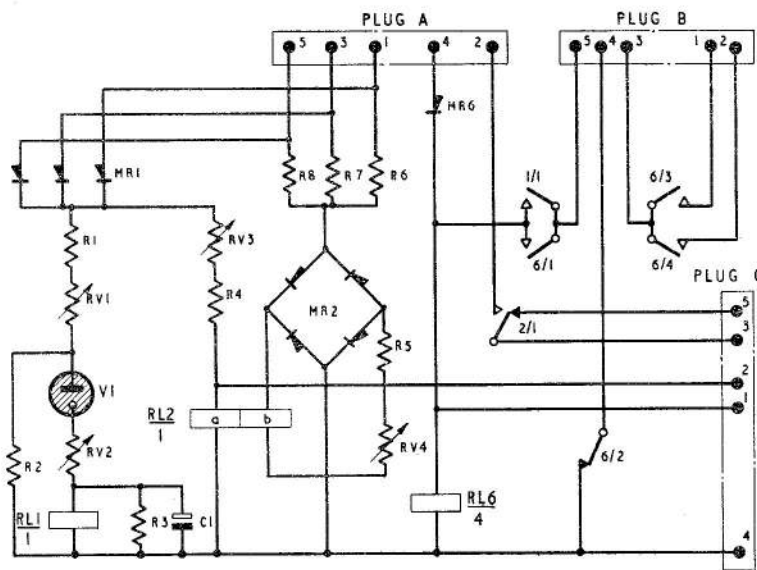

Fig. 5. Circuit diagram of voltage control panel

operating coil of relay RL4; relay RL4 closes and supplies 28V d.c. to the operating coil of the main contactor, which closes, and connects the generator to the busbars.

Under-voltage conditions

8. When the phase voltages are normal, the contacts of relay RL2 are made to supply 28V d.c. to the coil of relay RL5, when any one of the phase voltages drops to approx. 90V, the

unbalanced voltage detected by coil B produces ampere turns in coil B in opposition to that of coil A, and the contacts change over. The operation of RL2 removes the supply from relay RL5, which changes over after 3 to 5 seconds, the supply being maintained during this time by the discharge of capacitor C4. When relay RL5 changes over the 28V d.c. supply to the coil of relay RL6 is completed; this circuit is connected through the

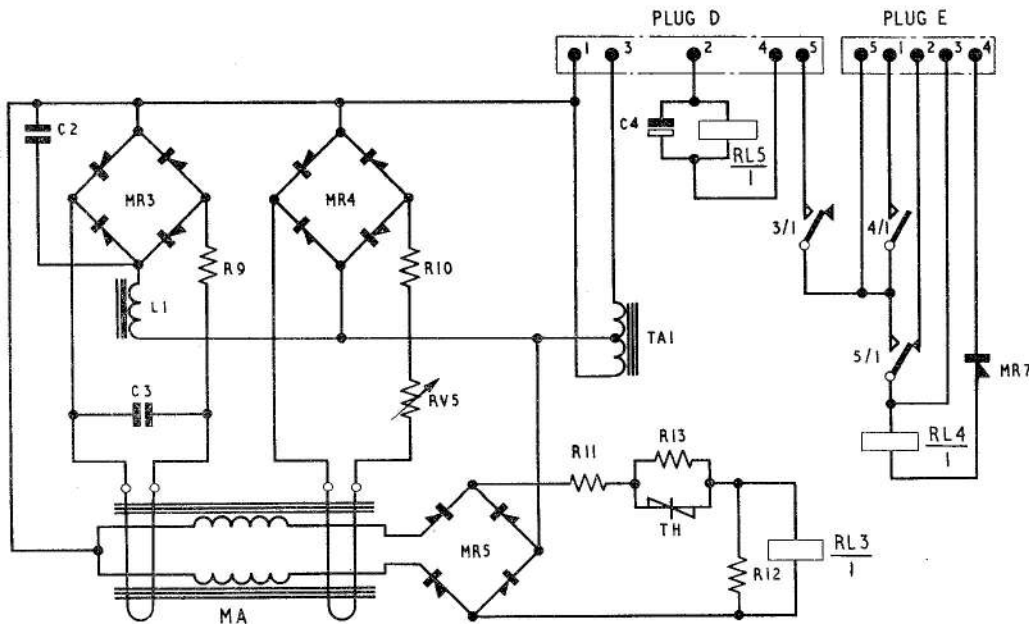

Fig. 6. Circuit diagram of under-frequency panel

RESTRICTED

contacts of RL3 when energized, through the normally made contacts of relay RL2 and relay RL5, through the blocking rectifier MR6 to the coil of relay RL6. Relay RL6 operates, and its normally open contacts close to maintain itself energized and to short-circuit the primary windings of the voltage regulator compounding transformers, thereby de-energizing the generator field, and its normally made contacts break to open the hold-in circuit of relay RL4. Relay RL4 opens to remove the supply from the main contactor.

Over-voltage conditions

9. When the average phase voltage exceeds a predetermined limit, the reference diode V1 strikes and after a time delay relay RL1 operates. When the relay is energized its contacts close to supply 28V d.c. to the coil of relay RL6, thus removing the supply from the main contactor and de-energizing the generator field.

Under-frequency condition

10. When the frequency is lower than approx. 380 c/s the sum of the ampere turns of the magnetic amplifier control and polarizing windings, is of a magnitude and polarity such that the magnetic circuit is desaturated. The output voltage will be insufficient to operate or maintain relay RL3, and the relay will remain open, or move from the closed to the open position. When the frequency rises above approx. 380 c/s the output voltage to the magnetic amplifier control winding rapidly decreases, the ampere turns at first cancel out, and then polarize the core such that the magnetic circuit is fully saturated; the full operating voltage will then be applied to the coil of relay RL3. When relay RL3 is open the 28V d.c. supply circuit through relay RL2 to the coil of RL5 is interrupted, RL5 opens after a time delay of 3 to 5 seconds and removes the supply to the coil of relay RL4. Relay RL4 opens and removes the supply to the main contactor. When RL3 is closed the opposite of the foregoing occurs. The main contactor then will be opened when the frequency is less than 380 c/s and closed when the frequency is greater than 380 c/s.

SERVICING

General

11. The control unit should be serviced in accordance with the relevant Servicing Schedule. The voltage control and under-frequency control panels should be removed and their

components examined for signs of damage, corrosion and deterioration, and for security of attachment. All electrical connections and soldered joints should be checked for tightness and the wiring examined for signs of deterioration of insulation. Collection of dust and other foreign matter should be blown out using a jet of dry, clean, compressed air. The unit should be tested and adjusted in accordance with the instructions given in paras. 12 to 18.

Testing

12. The power supplies required for checking the operation of the unit should be equivalent to those used on the particular aircraft system. The supply should be 3-phase, 4 wire, with each phase variable between 80-150 volts and 370-400 c/s. The time delay of the circuits should be measured using a time interval meter, Model 25E, Ref. No. 63H/118 or a suitable equivalent. The procedures for testing given in the following paragraphs detail the test and adjustment of the individual panel assemblies, after which, the panels are assembled into the box and the unit is tested as a whole.

Voltage control panel

13. *Over-voltage circuit.* Connect the voltage control panel to the test circuit as shown in fig. 7. The connection from RV1 to the voltage reference diode V1 should be diverted through switch S1 and a suitable voltmeter (min. 20,000 ohms/volts) should be connected across V1 as shown in the test circuit. The circuit should be checked for correct operation as follows.

Note . . .

The supply should be switched off before making adjustment to RV1.

(1) Ensure that the switch in series with the reference diode V1 is closed, increase the supply voltage to $125 + 3$ volts and adjust RV1 so that V1 strikes (indicated by the voltmeter reducing to approx. 90 volts). Remove the voltmeter from the circuit.

(2) Vary the supply voltage over the range given by the graph (fig. 8), adjust RV2 to obtain the over-voltage time delay characteristics as shown. The test circuit is arranged so that the time interval meter is started when S1 is closed and is stopped by the operation of the lock-out relay RL6. With S1 open,

RESTRICTED

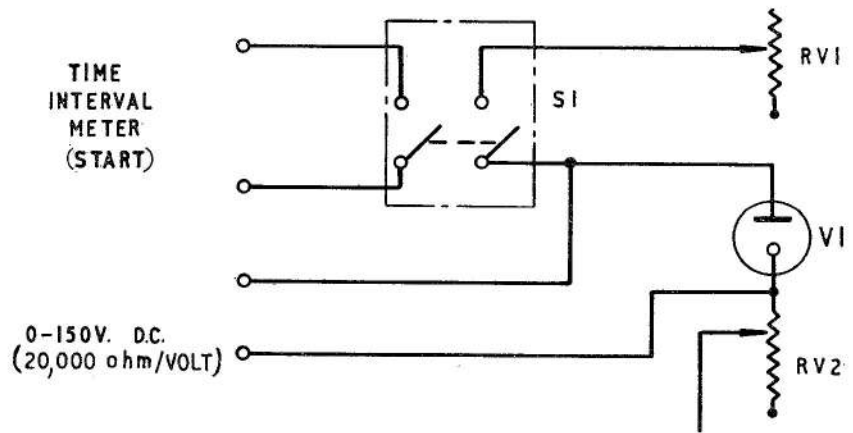
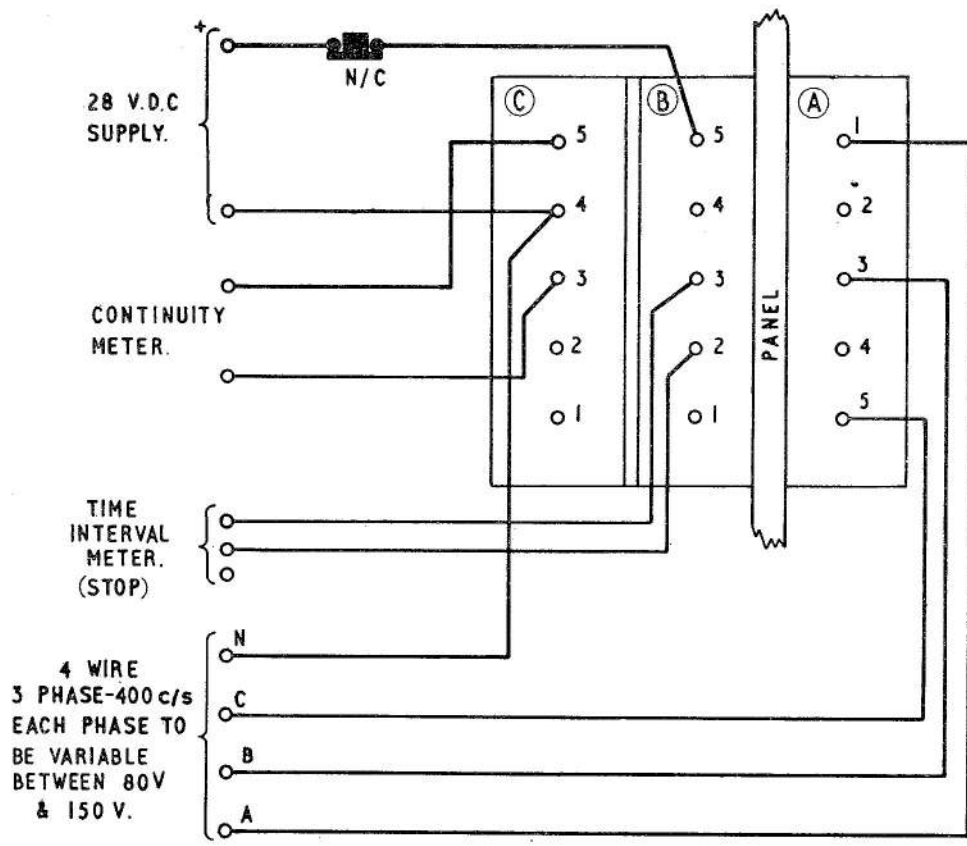

Fig. 7. Voltage control panel test circuit diagram

RESTRICTED

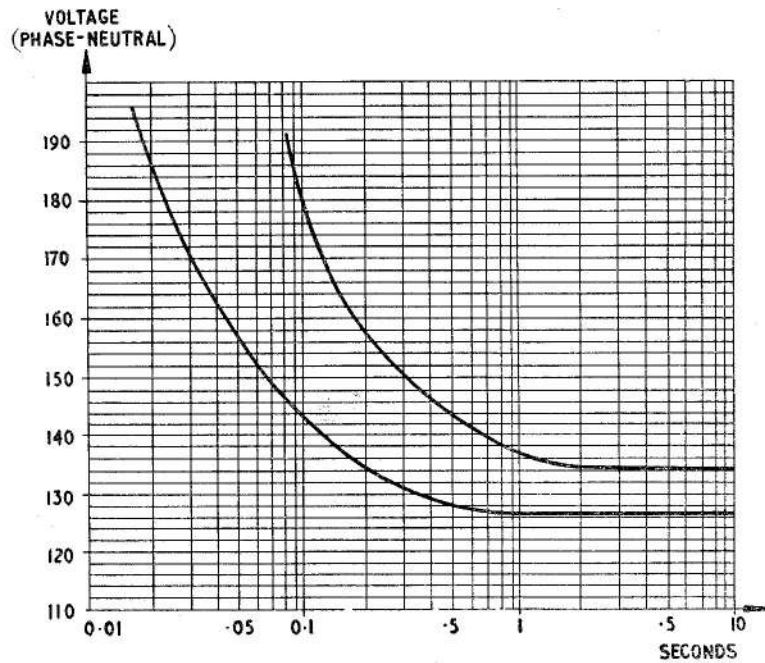

Fig. 8. Over-voltage circuit time delay characteristics

operate the N/C push-switch momentarily after each operation, to remove the supply from the coil of RL6.

(3) If it is necessary to readjust RV1 to obtain the settings to the graph limits, the procedure given in sub-para. (2) should be repeated.

(4) Disconnect the time interval meter, remove S1 from the circuit and reconnect voltage reference diode.

14. Under-voltage circuit. With the control unit connected to the test circuit as shown in fig. 7, but with the 28V d.c. supply and the time interval meter removed, test for under-voltage and out-of-balance conditions as follows.

(1) Increase the supply voltage equally on all three phases from zero until relay RL2 is energized, indicated by continuity meter reading open circuit. Relay RL2 should become energized before attaining 112V (phase).

(2) Decrease the supply voltage equally on all three phases to 90 ± 5 volts (phase), and adjust RV3 until RL2 is de-energized indicated by a short circuit

(low resistance) reading on the continuity meter.

(3) Repeat the procedure given in sub-para. (1) and (2) to ensure operation of RL2 within the limits stated.

(4) Adjust the supply voltage to 120 volts (phase), reduce phase A to 90 ± 5 volts and adjust RV4 until relay RL2 becomes de-energized.

(5) Repeat sub-para. (4) with phase B reducing to 90 ± 5 volts, then with phase C reducing to 90 ± 5 volts.

(6) Adjust RV4 to obtain a mean value of voltage for the operations in sub-para. (4) and (5).

Note . . .

When making the adjustments detailed in sub-paras. 4 and 5, RV3 should be used in conjunction with RV4 to obtain the correct settings.

Under-frequency control panel

15. Connect the under-frequency control panel to the test circuit as shown in fig. 9, and check the circuit for correct operation as follows.

RESTRICTED

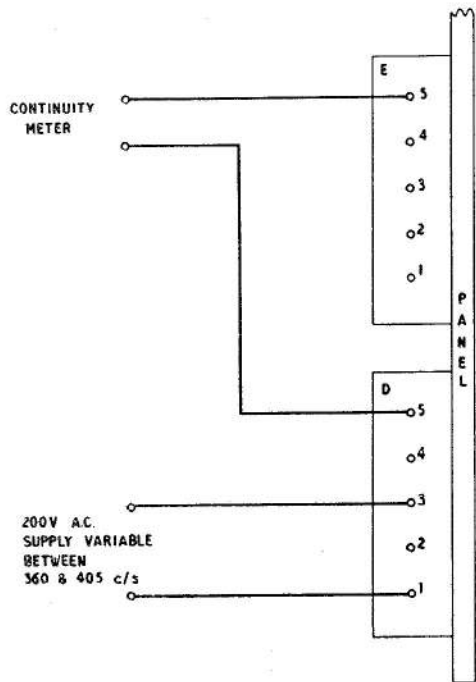

Fig. 9. Under-frequency panel test circuit diagram

Note . . .

The supply should be switched off before making adjustment to RV5.

(1) Increase the supply voltage equally on all three phases to normal and adjust the frequency to 400 c/s.

(2) Decrease the frequency to 378 ± 3 c/s, maintaining normal supply voltage, and adjust RV5 until relay RL3 is de-energized indicated by the continuity meter reading open circuit.

(3) Increase the frequency and check that relay RL3 becomes energized at 381 ± 6 c/s.

(4) Repeat the procedures given in sub-para. (2) and (3) to ensure operation of relay RL3 within the limits stated.

Unit assembled

16. The test instructions given in the following paragraphs are applicable to the complete unit and should be performed after the voltage control panel and under-frequency control panel are assembled and all connections made. The unit should be connected to the test circuit as shown in fig. 10 and tested as follows.

Note . . .

The continuity meter must not be left in circuit for the tests detailed in sub-para. (9) and (10).

(1) Connect the 28V d.c. supply to pins G and P, increase the a.c. supply voltage to 120V (phase) and set frequency to 375 c/s.

(2) Increase the frequency and check that the d.c. supply voltage appears across pins D and P (indicated by V1) when the frequency is 381 ± 6 c/s. The

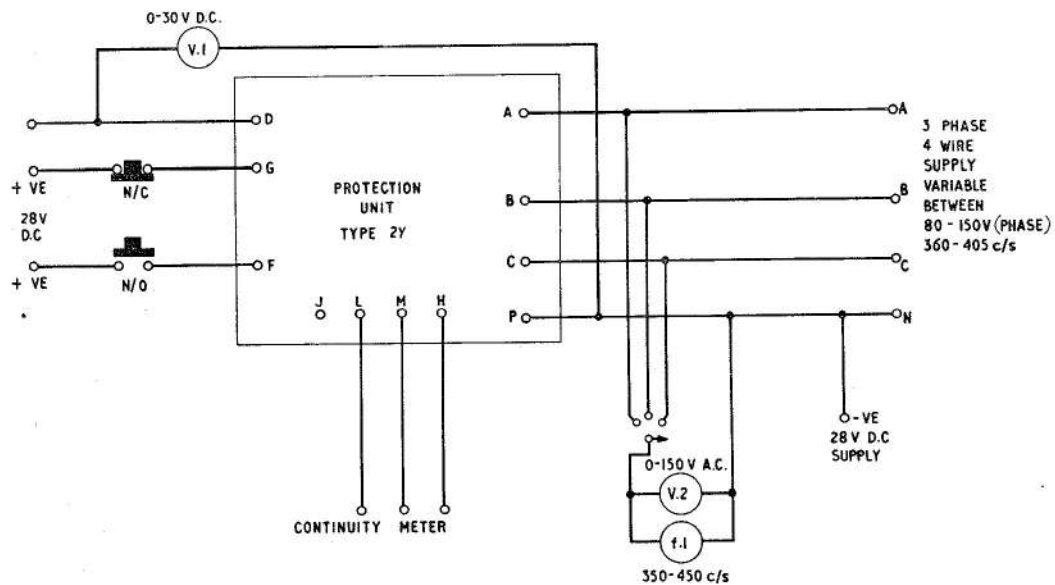

Fig. 10. Unit test circuit diagram

RESTRICTED

continuity meter should indicate open circuit pins H-L and H-M.

(3) Decrease the frequency and check that the d.c. supply voltage disappears from pins D and P when the frequency is 378 ± 3 c/s.

(4) With normal voltage applied and the frequency adjusted to 387 c/s, decrease the frequency rapidly to 375 c/s and check the time delay for the d.c. supply voltage to disappear from pins D and P. The time delay should be within the limits of 3 to 5 seconds.

(5) With the frequency set to 400 c/s, instantaneously decrease the supply voltage equally on all three phases to 90 ± 5 volts (phase). After a time delay of 3 to 5 seconds, the d.c. supply voltage across pins D and P should disappear and continuity should be indicated between pins H-L and H-M. Increase the supply voltage to normal and operate the N/C push-switch momentarily to de-energize RL6.

(6) Increase the supply voltage on all three phases to 130 ± 4 volts, after a

short time delay period the voltage across pins D and P should disappear.

(7) Adjust the supply voltage to 120 volts, reduce phase A to 90 ± 5 volts and check the circuit operation as in sub-para. (5).

(8) Repeat sub-para. (7) with phase B reducing to 90 ± 5 volts, then with phase C reducing to 90 ± 5 volts.

(9) With normal voltage and frequency applied to the unit, check that the continuity meter indicates open-circuit between pins H-L and H-M.

(10) Energize the unit from a normal source of supply with the voltage adjusted to 112 volts (phase) and the frequency adjusted to 396-400 c/s, then run up the system from zero rev/min and ensure that the 28V d.c. supply voltage appears across pins D and P when a steady a.c. supply state is attained.

(11) Operate the N/O push-switch to supply 28V d.c. to pin F and check the circuit operation as follows.

(a) Continuity should be indicated between pins H-L and H-M.

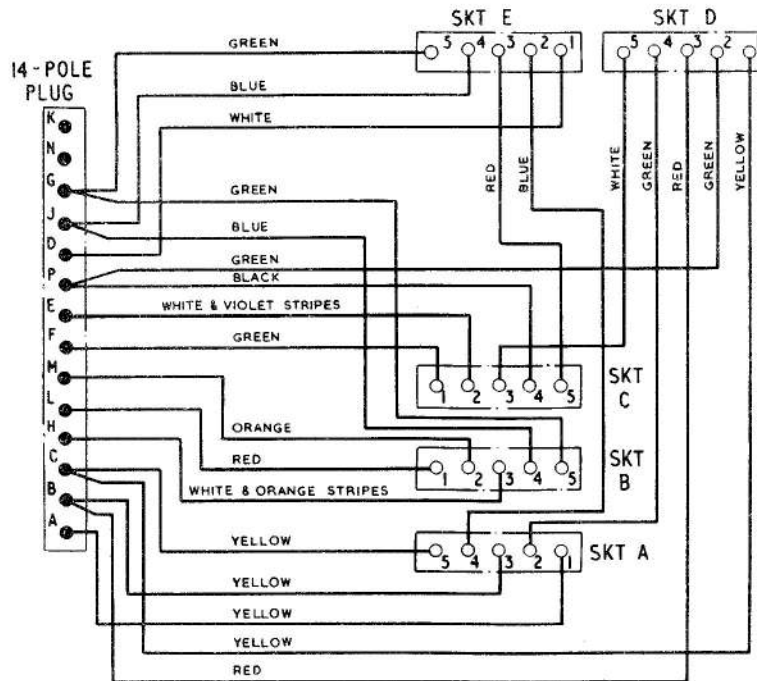

Fig. 11. Circuit diagram, plug/socket connections

RESTRICTED

(b) The d.c. supply voltage across pins D and P reduces to zero.

(c) Open circuit is indicated between pins J and P. Operate N/C push-switch momentarily to de-energize RL6.

(12) Remove the supply and check that continuity is indicated between pins J and P.

Continuity test

17. With the voltage control panel and the under-frequency control panel removed from

the box, test for continuity between the plug/socket interconnections using the circuit diagram (fig. 11).

Insulation resistance test

18. Using a 250V insulation resistance tester measure the insulation resistance between all pins on the UK-AN connector and the case. The minimum permissible reading should exceed 5 megohms.

RESTRICTED

This file was downloaded
from the RTFM Library.

Link: www.scottbouch.com/rtfm

Please see site for usage terms,
and more aircraft documents.

