

See AP(137)-0723-16 not held 'C'

Chapter 4
CONTROL AND PROTECTION UNIT,
ROTAX, TYPE U3704

LIST OF CONTENTS

	<i>Para.</i>		<i>Para.</i>
<i>Introduction</i>	1	<i>Undervoltage indication</i>	23
Description	2	<i>Pulsed a.c. tickle supply</i>	25
Operation	6	<i>Earth leakage indication</i>	30
<i>Voltage control</i>	11	<i>System inoperative</i>	32
<i>Operation at 200-250 c/s</i>	17	Installation	33
<i>Overtoltage protection</i>	19	Servicing	
<i>Feeder protection</i>	21	<i>Insulation resistance tests</i>	34

LIST OF TABLES

	<i>Table</i>
<i>Circuit component details</i>	1

LIST OF ILLUSTRATIONS

	<i>Fig.</i>		<i>Fig.</i>
<i>Layout of components (1)</i>	1	<i>Layout of components (3)</i>	3
<i>Layout of components (2)</i>	2	<i>Circuit diagram</i>	4

LIST OF APPENDICES

	<i>App.</i>
<i>Control and protection unit, Rotax, Type U3704/2</i>	1

LEADING PARTICULARS

Control and protection unit, Type U3704/1	<i>Ref. No. 5UC/6587</i>
<i>Output voltage</i>	208 volts a.c. \pm 4 per cent
<i>Phase</i> 3
<i>Frequency</i>	250 to 400 c/s. overall
<i>Load range</i> 0-21 kVA
<i>Power factor</i> Unity to 0.9 lag.
<i>Temperature range</i>	-40 deg. C. to +50 deg. C.
<i>Altitude</i> 30 000 ft.
<i>Cooling</i> Natural
Overall dimensions	
<i>Length (over handle)</i> 11.750 in.
<i>Width</i> 9.250 in.
<i>Height</i> 8.500 in.
<i>Weight</i> 21.5 lb.

RESTRICTED

Introduction

1. The control and protection unit, Type U3704, is designed to control and protect the output of the 22 kVA a.c. generators, Types N0407 and N0408 which are used in aircraft de-icing systems. This chapter describes in detail the U3704/1; the U3704/2 incorporates radio suppression and some minor circuit alterations, and is covered in Appendix 1 to this chapter. ▶

DESCRIPTION

2. The components are housed within an alloy box, the cover of which incorporates perforated panels to provide ventilation.
3. The components are mounted on two chassis, one fixed and the other hinged; by turning the hinged chassis about the hinge pin, access is gained to all components. Each component is identified by code symbols which are directly related to the circuit diagram (fig. 4).
4. The equipment is suitable for operating at altitudes of up to 30 000 ft. within a temperature range of -40 deg. C. to $+50$ deg. C.
5. Fig. 1, 2 and 3 show the physical layout of the components in the unit.

OPERATION

6. Operation of the U3704/1 is based on the use of magnetic amplifiers, by which means accurate control of the output voltage and effective protection arrangements are achieved. A theoretical diagram of the internal connections is given in fig. 4.
7. Minor adjustments of the controlled voltage level can be made with the voltage trimmer potentiometer (1RV3), which is located behind the swing cover plate on the front of the unit, above the data plate; adjustment can be made in approximately 1 V steps to ± 9 V without the necessity of disturbing the unit cover.
8. Regulation of the busbar voltage is obtained by a system operation which is based entirely on the use of magnetic amplifiers. Control of the average of the

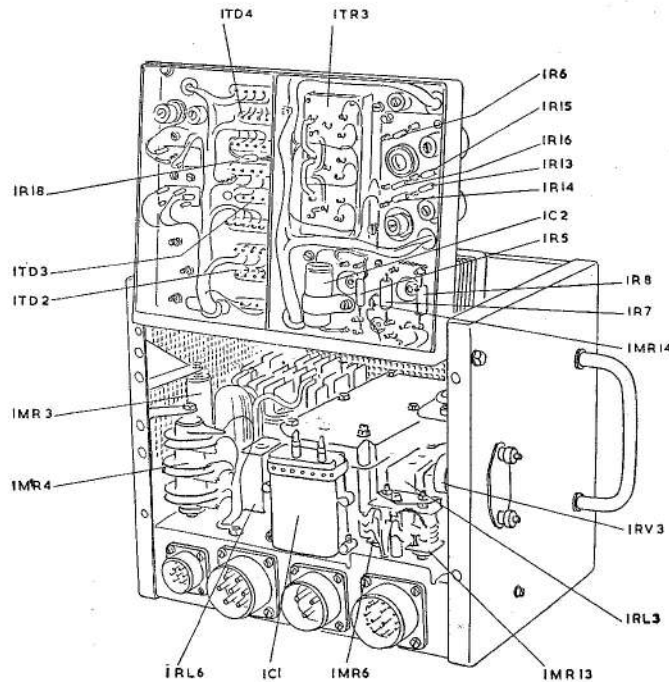

Fig. 1. Layout of components (1)

three r.m.s. line voltages is maintained at 208 volts ± 4 per cent over a frequency range of 250–400 c/s and a load range of no-load to 22 kVA.

9. Protection is provided against over-voltage and feeder faults up to the busbars, and indication of under voltage and earth leakage faults is provided. Indication is also given in the event of the system becoming inoperative.

10. These protective functions are effected by employing magnetic amplifiers to control pilot relays which in turn control the main switchgear or indicators. Each magnetic amplifier is adjusted to develop an infinite gain characteristic thereby providing a 'trigger' action for the control of the pilot relay. This renders the protection arrangements insensitive to variations in temperature, frequency and voltage. In addition, an inverse time characteristic is introduced by incorporating short-circuited turns, which allows the switchgear and indication circuit to ignore load switching transients.

Voltage control

11. Accurate regulation of the busbar voltage is obtained by closed loop control of the alternator excitation. Two factors are

RESTRICTED

considered in effecting this control, i.e., the load current delivered by the alternator and the error between the desired line voltage and actual line voltage.

12. Excitation current proportional to load current is supplied to the alternator field via the current compounding transformer ITR1 and silicon rectifier 1MR1. As this source of excitation is linear and the alternator characteristic is not, then the balance of excitation must be provided by the voltage regulator. Components of the voltage regulator include:—

(a) A voltage sensitive network, comprising two circuits, one containing resistors 1R5, 1R6, 1RV2 and 1RV3, the other the barretter 1L1 and resistor 1R20.

(b) An error magnetic amplifier, comprising transducer 1TD2 and rectifier 1MR7.

(c) A power magnetic amplifier comprising three-phase transducer 1TD1 and main auto-rectifier 1MR4.

13. Sensing of the error between the desired line voltage and the actual line voltage is dependent upon the comparison of two resistive circuits of the voltage sensitive network. One circuit, containing resistors 1R5, 1R6, 1RV2 and 1RV3, provides a linear voltage/current relationship, whilst the other circuit, containing barretter 1L1, gives an almost constant current. The two signal currents are then fed in opposing senses to the control windings of the error amplifier 1TD2. The resistor 1R20, connected in series with the barretter, is included to suppress surges which, in low temperature conditions, can cause false starting of the unit.

14. Current in the resistor circuit is adjusted such that at the required busbar voltage the signal currents in each circuit are nominally equal. In practice, a slight unbalance of currents at this desired voltage level obviates the use of a bias winding on transducer 1TD2. Any change in the average of the

F.S./2

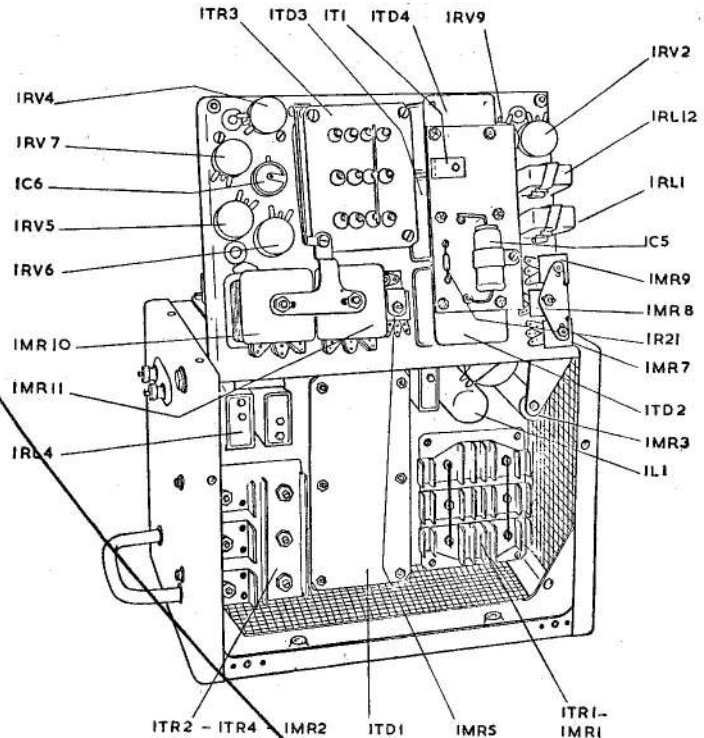

Fig. 2. Layout of components (2)

three r.m.s. line voltages above or below the nominal level will be detected by the voltage sensitive network. The error signal will then be fed into the error amplifier 1TD2, the output of which is, in turn, fed as a negative control into the power magnetic amplifier (1TD1 and 1MR4). The resultant output from the power magnetic amplifier is supplied to the alternator field as the modified excitation contribution of the regulator, thereby correcting the voltage error.

15. The purpose of the error magnetic amplifier (1TD2 and 1MR7) is to relieve the duty of the power magnetic amplifier. This improves stability with temperature variation and reduces the overall time constant of the regulator.

16. Bias and negative feedback loops are included to provide optimum operating conditions, e.g., a positive bias signal is applied to 1TD1 to compensate for the standing output of the error amplifier. Stabilization of the closed loop voltage regulating system is provided by transient

RESTRICTED

negative feedback networks passed over each amplifier stage, e.g., a signal proportional to the output current of transducer 1TD2 is derived across the coupling potentiometer 1RV7 and is fed to the control winding of 1TD2 via the network 1C3 and 1R17. Similarly, in the output stage a three-phase voltage, proportional to the field voltage, is applied via rectifier 1MR3 to the control winding of 1TD1 via the capacitor 1C1.

Operation at 200-250 c/s

17. To maintain generation at low alternator speeds, i.e., in the frequency range of 200-250 c/s (for a load of 16 kVA), without exceeding the current rating of the regulator, necessitates limiting the maximum current delivered by the regulator to approximately 12 amp. d.c. Automatic current limiting is achieved by comparing a d.c. signal derived from current transformer 1TR4, via rectifier 1MR13, with the d.c. signal in the resistor arm (1R5, 1R6, 1RV2 and 1RV3) of the voltage sensitive network. The turns ratio

of 1TR4 is such, that for regulator currents not greater than the nominal rating of excitation rectifier 1MR2, the output from 1MR13 is less than the current flow via 1R5, 1R6, 1RV2, 1RV3. Under normal operating conditions therefore, the output of 1MR13 has no effect in the controlled voltage level.

18. When the regulator current exceeds the nominal rating of 1MR2 the output of 1MR13 exceeds the current flowing in the resistors, so increasing the current flow in this resistor arm. The voltage regulator interprets this as a high voltage condition causing a reduction in excitation contribution and a progressive reduction in line voltage level with reduction in alternator speed. With further application of load the actual line voltage, under these conditions, will show a further reduction.

Overvoltage protection

19. Protection against an overvoltage condition is provided at a voltage level of 225 ± 5 volts. The circuit arrangement

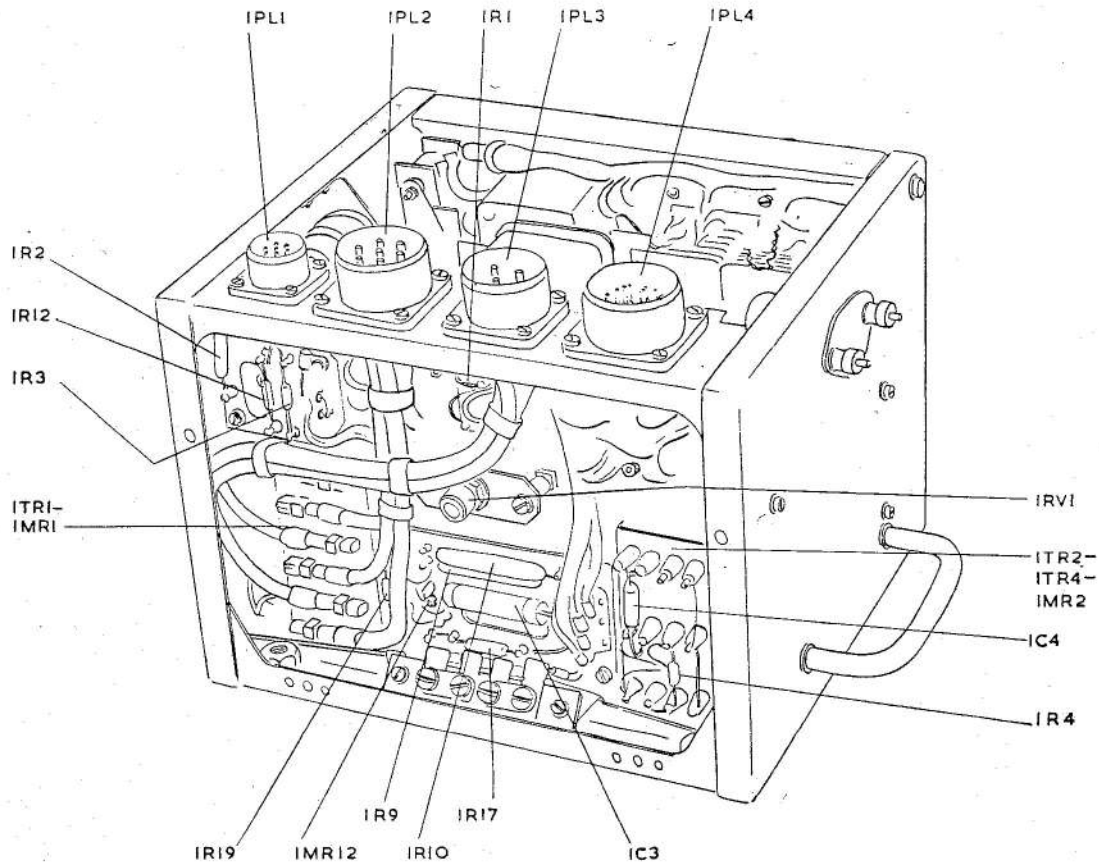

Fig. 3. Layout of components (3)

RESTRICTED

basically is formed by the combination of transducer 1TD3 and rectifier 1MR8, the output of which is applied to protection relay 1RL1. Positive feedback is applied to the transducer, thereby providing an infinite gain characteristic resulting in a trigger action for operation of the pilot relay 1RL1. Resistor 1R19 is inserted in the circuit to lock relay 1RL1. A voltage sensitive network, similar to the one described for voltage control, is incorporated in this protection arrangement, i.e., the voltage sensing is dependent upon the comparison of two resistive circuits which supply respective control windings of 1TD3. One resistive circuit of the network comprising 1R8, 1R13, 1R14 and 1RV6 provides the linear voltage/current relationship whilst the other circuit, which incorporates the barretter 1L1 and resistor 1R20, provides the constant current signal. Both resistive circuits are fed from the output of rectifier 1MR11.

20. At the nominal supply voltage the circuit is adjusted so that relay 1RL1 is de-energized. With an increase of supply voltage, transducer 1TD3 saturates, thereby energizing relay 1RL1, and subsequently isolating the alternator output from the busbar.

Feeder protection

21. Protection against line to line and line to neutral faults is provided by a modified Merz-Price system. Two three-phase, delta connected transformers are employed, one being connected adjacent to the alternator star point circulating current (in alternator terminal block) (2TR1) and the other close to the busbars (3TR1).

22. Under normal operating conditions a state of potential balance exists between the two transformers. Any feeder fault up to the busbar will increase the output of transformer 2TR1 above that of 3TR1. A potential will then be applied to rectifier 1MR6, the output of which is fed into control windings of protection transducer 1TD3 and is interpreted as an overvoltage condition. Relay 1RL1 is therefore energized and 1RL3 subsequently de-energized (via 1RL4 and 1R12) thereby short-circuiting the alternator field to switch off the alternator.

Undervoltage indication

23. Indication of an undervoltage condition is provided at a voltage level of 174 ± 5 volts.

Transducer 1TD4, rectifier 1MR9 and a voltage sensitive network provides the basis of the undervoltage indicator arrangement. The voltage sensitive network incorporates two resistive circuits, one comprising resistors 1R7, 1R15, 1R16, and 1RV5, and the other barretter 1L1 and resistor 1R20. The function of the network is exactly as described for the voltage control and overvoltage protection sensing arrangements.

24. An infinite gain characteristic is exhibited by 1TD4 and is thereby similar to the overvoltage protection transducer 1TD3. A difference exists between the two transducer arrangements such that the control windings of 1TD4 are reversed compared with the windings of 1TD3. Hence in the event of an undervoltage condition occurring in the system 1TD4 saturates, energizing 1RL2 and subsequently causing lamp 3L1 to give the appropriate undervoltage indication.

Pulsed d.c. tickle supply

25. The pulsed d.c. tickle circuit enables the supply to the panel to be controlled when, in starting, the voltage drops to too low a level for the panel to be self-exciting. Under this condition the starting resistors 1R9 and 1R10 carry approximately 200 W each and the pulsed d.c. tickle circuit prevents this overload from continuing for longer than approximately 5 sec.

26. With a 28 V d.c. supply at 3SW1 and with the switch in the RUN position, the following conditions occur:—

(1) The lamp 3L2 (alternator failure warning) is energized via the normally closed contacts of the aircraft relay, supplied by 1PL4, pin D.

(2) A 28 V d.c. supply appears at the normally open contacts of 1RL5 via the normally closed contacts of 1RL6, supplied by 1PL4, pin A.

(3) A 28 V d.c. supply is applied to 1RL3 via 1PL4 pin B, the normally closed contacts of relays 1RL4 and 1RL1, and rectifier 1MR12.

(4) A 28 V d.c. supply is applied to 1RL5 via 1PL4 pin B, the normally closed contacts of relays 1RL4 and 1RL6, and transistor 1T1.

RESTRICTED

27. With relays 1RL3 and 1RL5 energized and with the alternator being driven, the machine field is separately excited. At the point when the alternator becomes self-excited, 1RL6 is energized, breaking the circuit at 1RL6, pins 21 and 22, and interrupting the supply to 1RL5 at pins 1 and 2 of 1RL6. With supply appearing at 1PL4 pin D, 3L2 is extinguished.

28. With the alternator at a standstill or being unable to attain a speed at which self-excitation can occur, 1RL5 is de-energized after a period (determined by 1C6, the resistance of the coil of 1RL5 and the current gain of 1T1) thus breaking the separate excitation circuit at pins 3 and 4 of 1RL5.

29. Reset action is achieved by moving switch 3SW1 to the KILL position, energizing relay 1RL4 via 1PL4 pin C. The supply is removed from 1PL4 pin B and thus 1RL3 and transistor 1T1. The voltage at 1C6 is removed by the resistance 1R21.

Earth leakage indication

30. An indication of earth leakage is provided, via lamp 3L1, when the earth leakage current exceeds 10 mA. In the event of a line being short-circuited to earth the appropriate indication will be given; the maximum fault current is effected by the inclusion of 1R4.

31. Should a fault occur the earth leakage current is rectified by 1MR5 and applied to transducer 1TD4, and is thereby interpreted as an undervoltage condition. Consequently lamp 3L1 lights to provide the required indication.

System inoperative

32. An indicator lamp 3L2 is fed from the 28 V d.c. busbar via the RUN/KILL switch and normally closed contacts on the auxiliary relay fitted to the aircraft. With the system functioning normally the contacts of the aircraft auxiliary relay are open (energized via 1PL4, pin D), and the lamp is extinguished. If the system becomes inoperative for any reason, with the RUN/KILL switch in the RUN position the auxiliary relay is de-energized and appropriate indication is given via lamp 3L1.

INSTALLATION

33. The unit must be mounted base downwards and secured by four 0.250 in. UNF

stiff anchor nuts located in the base of the unit. Electrical connections are made via four plugs mounted on the top of the unit.

SERVICING

Insulation resistance tests

34. Check the insulation resistance of the unit, as indicated in para. 35 to 42.

35. Common together pins A, B, C, D, E, F, and G on the socket for 1PL1, pins B, C, D, and P on the socket for 1PL4, pins D and E on the socket for PL2 and with flying leads and crocodile clips, the terminals A7, B7, C7, B9 and B10 on transformer 1TR3. Bring out the connection as a common lead. Also common together pins A, B and C on the socket for PL2 and bring out the connection as a common lead.

36. Common together pins K and L on the socket for PL4 and with flying leads and crocodile clips, terminals A5, B5 and C5 on transformer TR2 and terminals A3, B3, C3, C9, C10 of transformer 1TR2. Bring out the connection as a common lead.

37. Common together pins A and F on the socket for 1PL4 and bring out the connection as a common lead.

38. Common together pins J and H on the socket for 1PL4 and bring out the connection as a common lead. Also common together pins G and I on this socket and bring out the connection as a common lead.

39. Connect a separate lead to pin E on the above socket.

40. With flying leads and crocodile clips, common together terminals A9 and A10 on transformer TR3 and bring out the connection as a common lead.

41. Connect all but the first commoning lead to a suitable point on the chassis (e.g. shell of the connecting plug) and with a 500-volt insulation resistance tester check the insulation resistance; the reading should not be less than 5 megohms.

42. Repeat the insulation resistance test on each commoning lead in turn with the other seven remaining connected to the chassis. With a 500-volt insulation resistance tester the reading obtained should not be less than 5 megohms.

RESTRICTED

<i>Cct. Ref.</i>	<i>Description</i>	<i>Value</i>	<i>Part 1</i>
1R1	Bias resistor	620 Ω 3 W	
1R2	Feed back load resistor	10 K 4 $\frac{1}{2}$ W	
1R3	Feed back series resistor	390 Ω 1 $\frac{1}{2}$ W	
1R4	Leak limiter	6.8 K 1 $\frac{1}{2}$ W	
1R5	Signal resistor	100 Ω 3 W	
1R6	Signal trim resistor	33 Ω 1 $\frac{1}{2}$ W	
1R7	Undervoltage resistor	120 Ω 3 W	
1R8	Overvoltage resistor	150 Ω 3 W	
1R9	Starting resistor	4.7 Ω 6 W	
1R10	Starting resistor	4.7 Ω 6 W	
1R12	Field short ballast	1.2 K 3 W	
1R13	Overvoltage trim resistor	22 Ω 1 $\frac{1}{2}$ W	
1R14	Overvoltage trim resistor	22 Ω 1 $\frac{1}{2}$ W	
1R15	Undervoltage trim resistor	22 Ω 1 $\frac{1}{2}$ W	
1R16	Undervoltage trim resistor	22 Ω 1 $\frac{1}{2}$ W	
1R17	Current feedback resistor	1.5 K 3 W	
1R19	Relay hold resistor	680 Ω 1 $\frac{1}{2}$ W	
1R20	Barretter ballast resistor	22 Ω 1 $\frac{1}{2}$ W	
1R21	Pulsed tickle resistor	1 K 1 $\frac{1}{2}$ W	
1RV1	Output bias control	350 Ω $\frac{1}{2}$ W	
1RV2	Signal control coarse	25 Ω $\frac{1}{2}$ W	
1RV3	Signal control fine	25 Ω $\frac{1}{2}$ W	
1RV4	Merz-Price trim	100 Ω $\frac{1}{2}$ W	
1RV5	Undervoltage trim	25 Ω $\frac{1}{2}$ W	
1RV6	Overvoltage trim	25 Ω $\frac{1}{2}$ W	
1RV7	Coupling control	450 Ω $\frac{1}{2}$ W	
1RV9	Earth leakage trim	750 Ω $\frac{1}{2}$ W	
1RV10	Relay operate control	680 Ω	
1C1	Feedback capacitor	15 μ F 150 V d.c.	
1C2	Isolating capacitor	1 μ F 150 V d.c.	
1C3	Current feedback capacitor	40 μ F 12 V d.c.	
1C4	Output transducer control winding capacitor	10 μ F 6 V d.c.	
1C5	Earth leakage capacitor	1 μ F 150 V d.c.	
1C6	Pulsed tickle delay capacitor	140 μ F	
1MR1	Compounding rectifier		
1MR2	Excitation rectifier		
1MR3	Feedback rectifier		
1MR4	Main auto rectifier		
1MR5	Earth leakage rectifier		

Table 1
Circuit component details

<i>Number</i>	<i>Cct. Ref.</i>	<i>Description</i>	<i>Value</i>	<i>Part Number</i>
1MR6		Merz-Price rectifier		
1MR7		Pre-amp. rectifier		
1MR8		Protection rectifier		
1MR9		Indication rectifier		
1MR10		Contactor supply rectifier		
1MR11		Signal rectifier		
1MR12		Blocking rectifier		
1MR13		Current limiting rectifier		
1MR14		Blocking rectifier		
1RL1		Protection relay	1 c/o 1 BK	
1RL2		Undervoltage indication relay	1 c/o 1 BK	
1RL3		Field shorting relay	2 M 2 B (H.D.)	
1RL4		Lock out relay	4 B (H.D.)	
1RL5		Pulsed tickle relay	2 M 2 B (H.D.)	
1RL6		Separate excitation relay	2 M 2 B (H.D.)	
1TR1		Compounding transformer		P7302
1TR2		Excitation transformer		P7402
1TR3		Supply and reference transformer		P7501
1TR4		Current limiting transformer		
1TD1		Excitation transducer		P7102
1TD2		Pre-amp. transducer		P7201
1TD3		Overvoltage protection transducer		P7002
1TD4		Undervoltage indication transducer		P7003
1PL1		A.C. protection lines	7 × 22A	
1PL2		A.C. feed in and field	7 × 73A	
1PL3		A.C. feed out	3 × 73A	
1PL4		D.C. control lines	{ 2 × 41A 14 × 22A	
1T1		Pulsed tickle transistor		
1L1		Barretter		
2 ALT 1		Alternator		NO407 NO408 Part of Alternator P6601
2TR1		Merz-Price transformer		
3TR1		Merz-Price transformer		
3L1		Undervoltage warning lamp		
3L2		General failure indicator lamp		

RESTRICTED

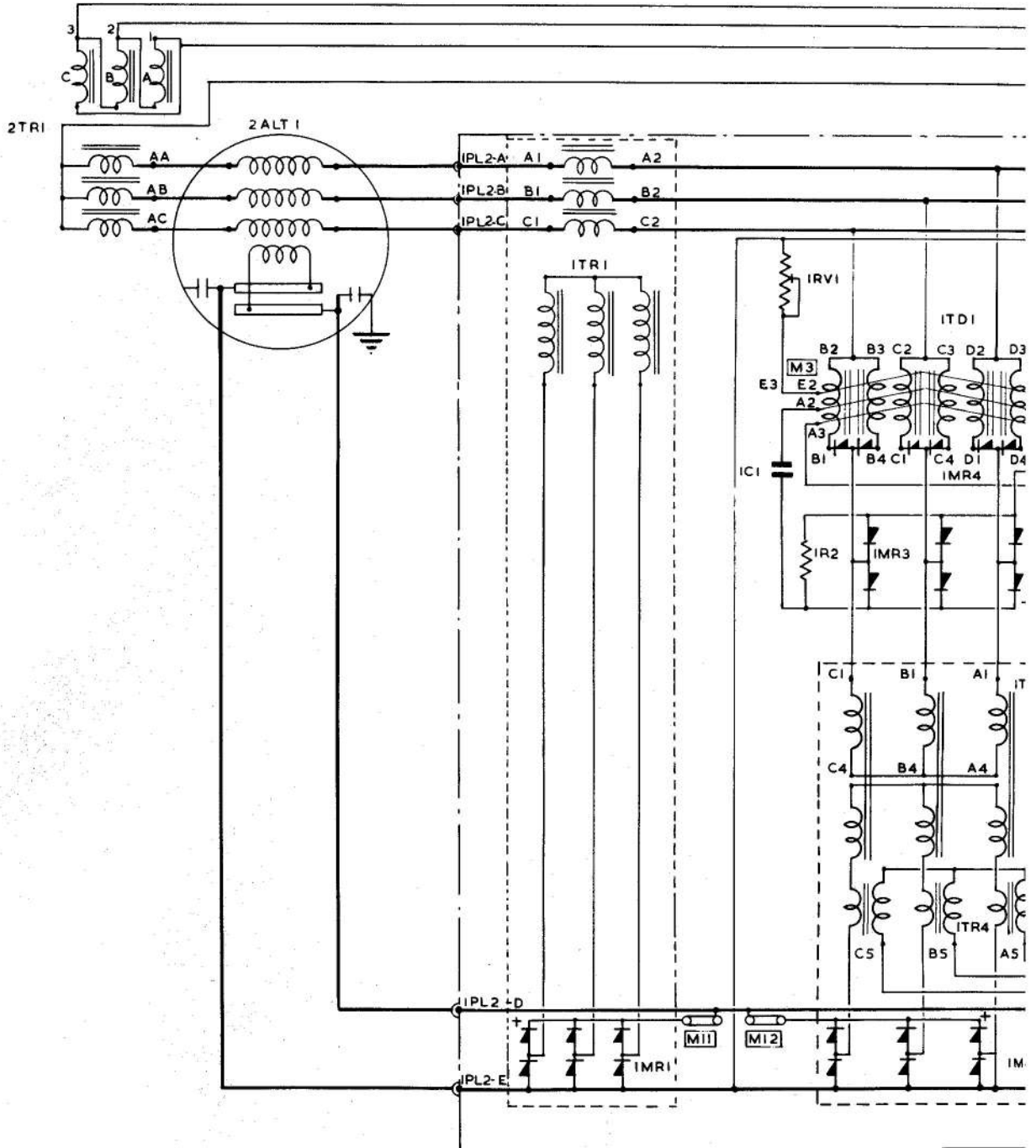
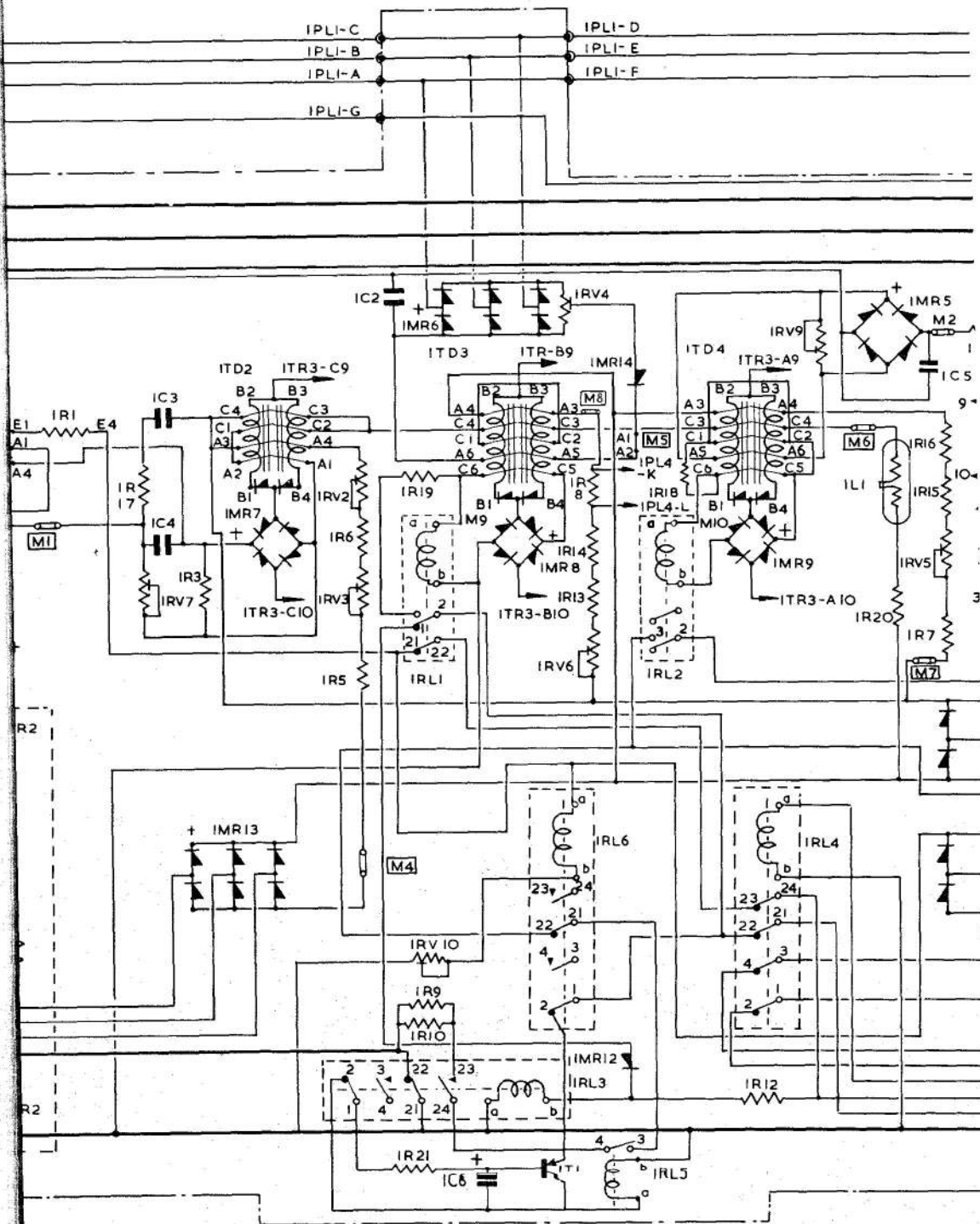
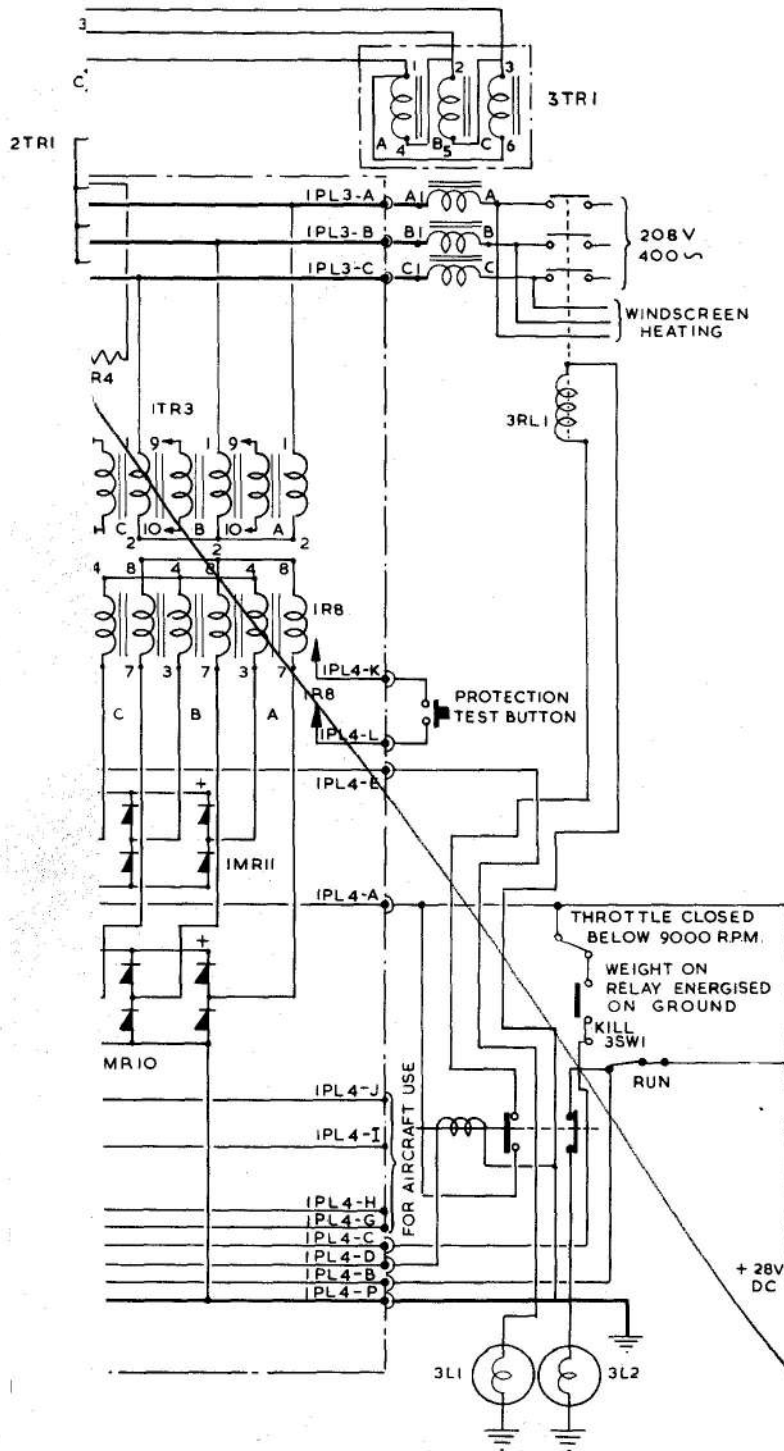

Fig.4



Circuit diagram
RESTRICTED



Fig

Fig.4

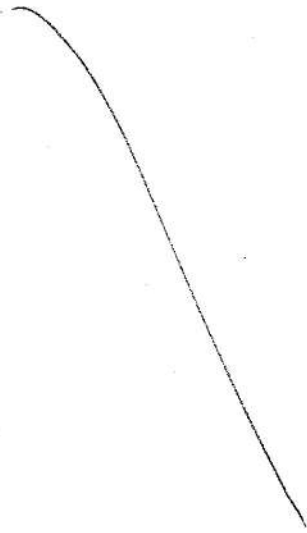

)

)

)

)

Appendix 1

CONTROL AND PROTECTION UNIT
ROTAX, TYPE U3704/2

LEADING PARTICULARS

Control and protection unit, Type U3704/2				Ref. No. 5UC/
Output voltage	208 volts a.c.	± 4 per cent	
Phase	3
Frequency	250 to 400 c/s	overall	
Load range	0-21 kVA	
Power factor	Unity to 0.9 lag	
Temperature range	-40 deg.C.	to +50 deg.C.	
Altitude	30 000 ft.	
Cooling	natural	
Length (over handle)	11.750 in.	
Width	9.250 in.	
Height	8.500 in.	
Weight	21.5 lb.	

1. The U3704/2 is identical to the U3704/1 as described in the main chapter except that the U3704/2 has radio suppression fitted and is modified internally to include circuit alterations, designed to overcome spurious indication in tropical environments, and to compensate for excessive volt drop in the aircraft wiring.

2. Additions and alterations to the unit have been made as follows (fig. 1 and Table 1A) :—

3. The circuit component details are as for Table 1 in the main chapter, except for the additions and alterations as follows:—

(1) Two triple capacitors (ZA6703) with four single capacitors have been added in the circuit to suppress radio interference.
(2) One leak limiter resistor 1R4 has been reduced in value to prevent spurious indication in tropical environments.

(3) One starting resistor 1R11 has been added and is connected in parallel with existing starting resistors 1R9 and 1R10; this has been introduced to compensate for excessive voltage drop in the aircraft wiring.

(Addendum to Chap. 4, Table 1)

Circuit component details

Table 1A

Cct. Ref.	Description	Value	Part Number
1R4	Leak limiter resistor	4.7K 1½W	N.113590/65
1R11	Starting resistor	4.7Ω 6W	N.113593/109
1C7	Capacitor	2 μF	N.45574
1C8	Capacitor	2 μF	N.45574
1C9	Capacitor	2 μF	N.45574
1C10	Capacitor	2 μF	N.45574
1C11	Three capacitors	0.5 μF	ZA.6703
1C12	Three capacitors	0.5 μF	ZA.6703

RESTRICTED

SERVICING

4. All soldered connections should be carefully inspected for dry and high resistance joints. Reference should be made to the theoretical circuit diagram (*fig. 1*) when applying tests detailed in para. 5 and 6 respectively.

Continuity test

5. (1) Using a low voltage bridge (e.g. Wheatstone), connect leads to the shells of PL1 and PL2. The resistance measured between PL1 and PL2 should not exceed 0.05 ohm.
- (2) Transfer the lead from the shell of PL2 to that of PL3. The resistance measured between PL1 and PL3 should not exceed 0.05 ohm.
- (3) Transfer the lead from the shell of PL3 to that of PL4. The resistance measured between PL1 and PL4 should not exceed 0.05 ohm.

Insulation resistance tests

6. (1) Common together pins A, B, C, D, E, F, G on a 7-pole socket (AN.3106A-16S-1S) for PL1, pins B, C, D, P on a 16-pole socket (AN.3106A-24-7S) for PL4,

pins D, E on a 7-pole socket (AN.3106A-24-10S) for PL2, and bring out connection as a common lead. On the above socket for PL2, common together pins A, B, C and bring out connection as a common lead.

Similarly, on the above socket for PL4, common together pins K and L and bring out as a common lead. Common together J and H on Socket for PL4 and bring out connection as a common lead. Common together pins G and I on socket for PL4 and bring out connection as a common lead. Connect separate leads to both pins A and E on socket for PL4.

(2) Connect all but the first commoning lead to a suitable point on the chassis e.g. the shell of the connecting plug, and measure the insulation resistance with a 500 volt insulation resistance tester. It should not be less than 5 megohms.

(3) Repeat the insulation resistance test between the chassis and each of the remaining commoning leads in turn, with the other six commoning leads connected to the chassis. In each case, the insulation resistance should not be less than 5 megohms.

RESTRICTED

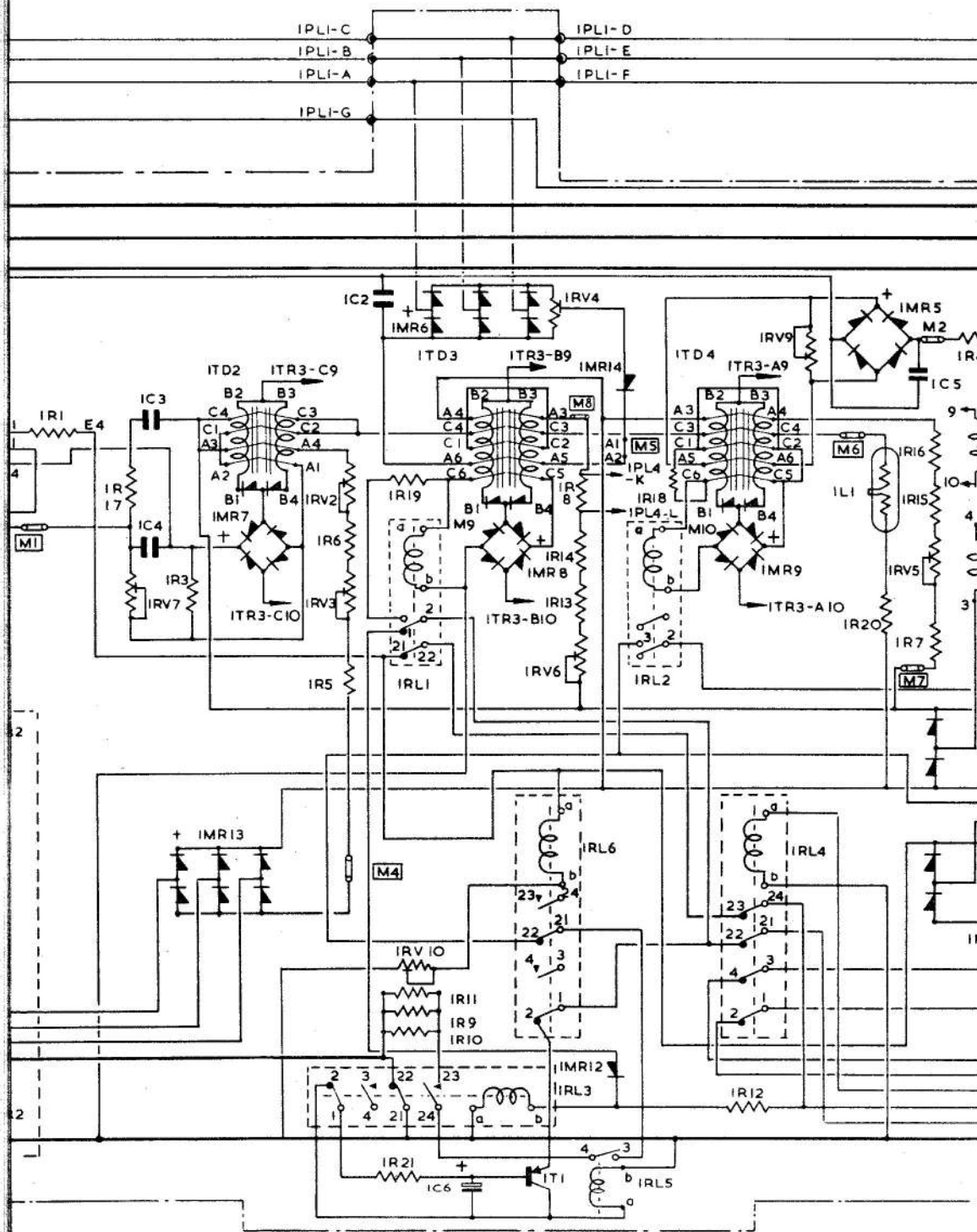

Circuit diagram
RESTRICTED

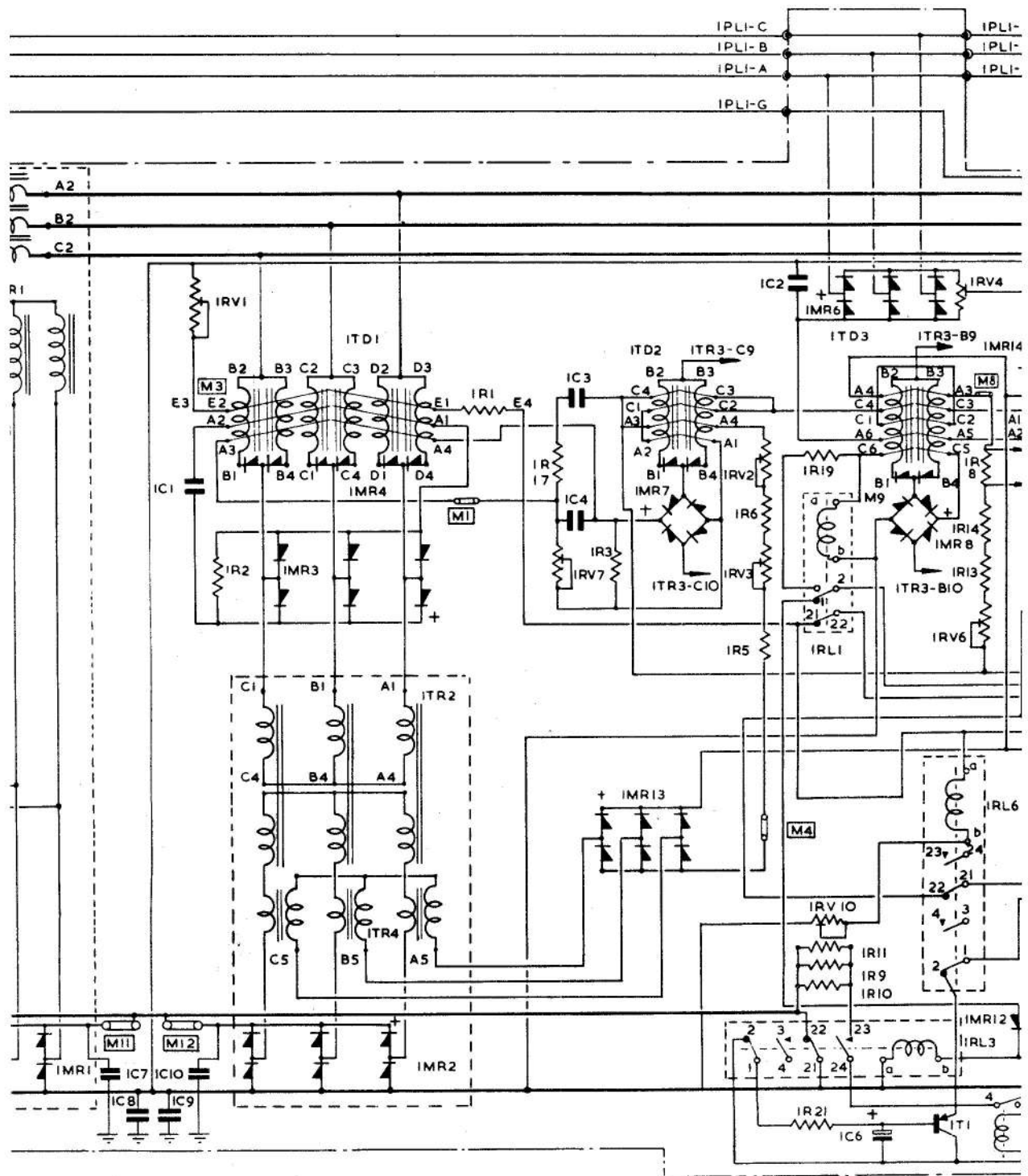

Circuit diagram
RESTRICTED

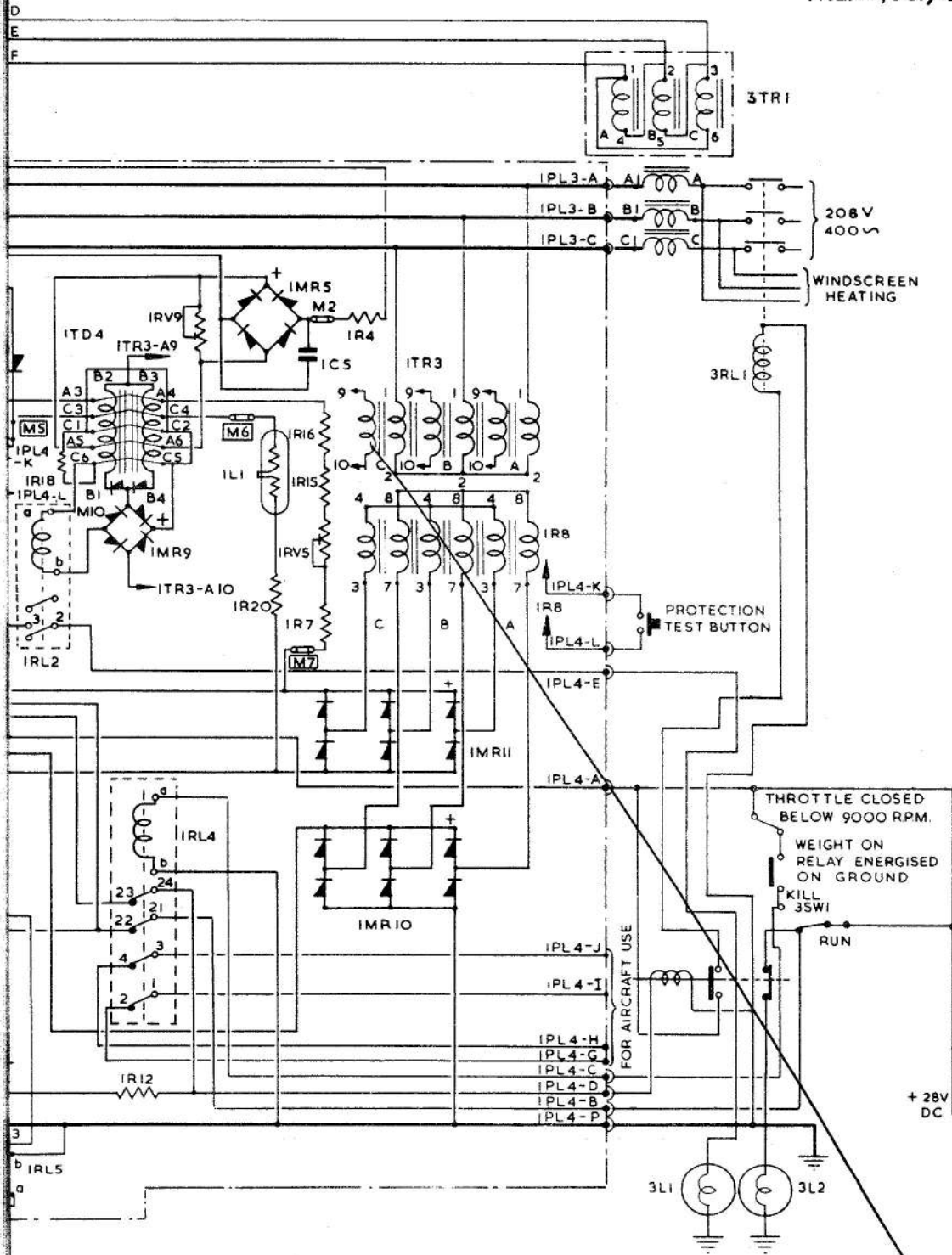

Fig. I

This file was downloaded
from the RTFM Library.

Link: www.scottbouch.com/rtfm

Please see site for usage terms,
and more aircraft documents.

