

Chapter 5
CONTROL PANEL, TYPE 6B, and CHOKE BOX, TYPE 1

LIST OF CONTENTS

	<i>Para.</i>								<i>Para.</i>
<i>Introduction</i>	1	<i>Choke box</i>							5
Description		Servicing							6
<i>Control panel</i>	3	<i>Testing</i>							10

LIST OF TABLES

		<i>Table</i>
<i>Plug and sockets</i>		1

LIST OF ILLUSTRATIONS

		<i>Fig.</i>
<i>Circuit diagram</i>		1

LEADING PARTICULARS

Control panel, Type 6B	<i>Ref. No. 5UC/3249</i>
<i>Voltage</i>	<i>28V d.c.</i>
<i>Incorporating—</i>	
<i>Starter, Type 16</i>	<i>Ref. No. 10F/1252</i>
<i>Rectifier</i>	<i>Ref. No. 5UC/2393</i>
<i>Fuse box, Type A</i>	<i>Ref. No. 5CZ/445</i>
<i>Fuse, Type A (20 amp.)</i>	<i>Ref. No. 5CZ/204</i>
<i>Suppressor, Type B, No. 1</i>	<i>Ref. No. 5CY/870</i>
<i>Voltage regulator, Type E11</i>	<i>Ref. No. 5UC/2966</i>
<i>Trimmer resistor (55-ohm.)</i>	<i>Ref. No. 5UC/3436</i>
Choke box, Type 1	<i>Ref. No. 5UC/2277</i>

RESTRICTED

Introduction

1. The control panel, Type 6B, is employed for controlling the a.c. output of the generator, Type UKX. The generator and the principle of control are described in A.P. 4343A, Vol. 1, Sect. 5; a circuit diagram, which includes the circuit for a.c. regulation, is shown in that chapter.

2. The control panel, Type 6B, used with special radio equipment, is very similar to the earlier Type 6, but incorporates an additional 8 μ F capacitor, connected as shown in the circuit diagram in fig. 1. The control panel is always used with the choke

box, Type 1, the latter being designed as a separate item for convenience in installation on certain aircraft.

DESCRIPTION

Control panel

3. The control panel consists of a right-angled chassis, comprising a vertical panel and a base plate. This fits into a tray secured to the airframe on two mountings, Type 77 (Ref. No. 10AB/232). The chassis is provided with two spring-loaded plungers which engage with locating holes at the rear of the tray. The chassis is secured by means of two short

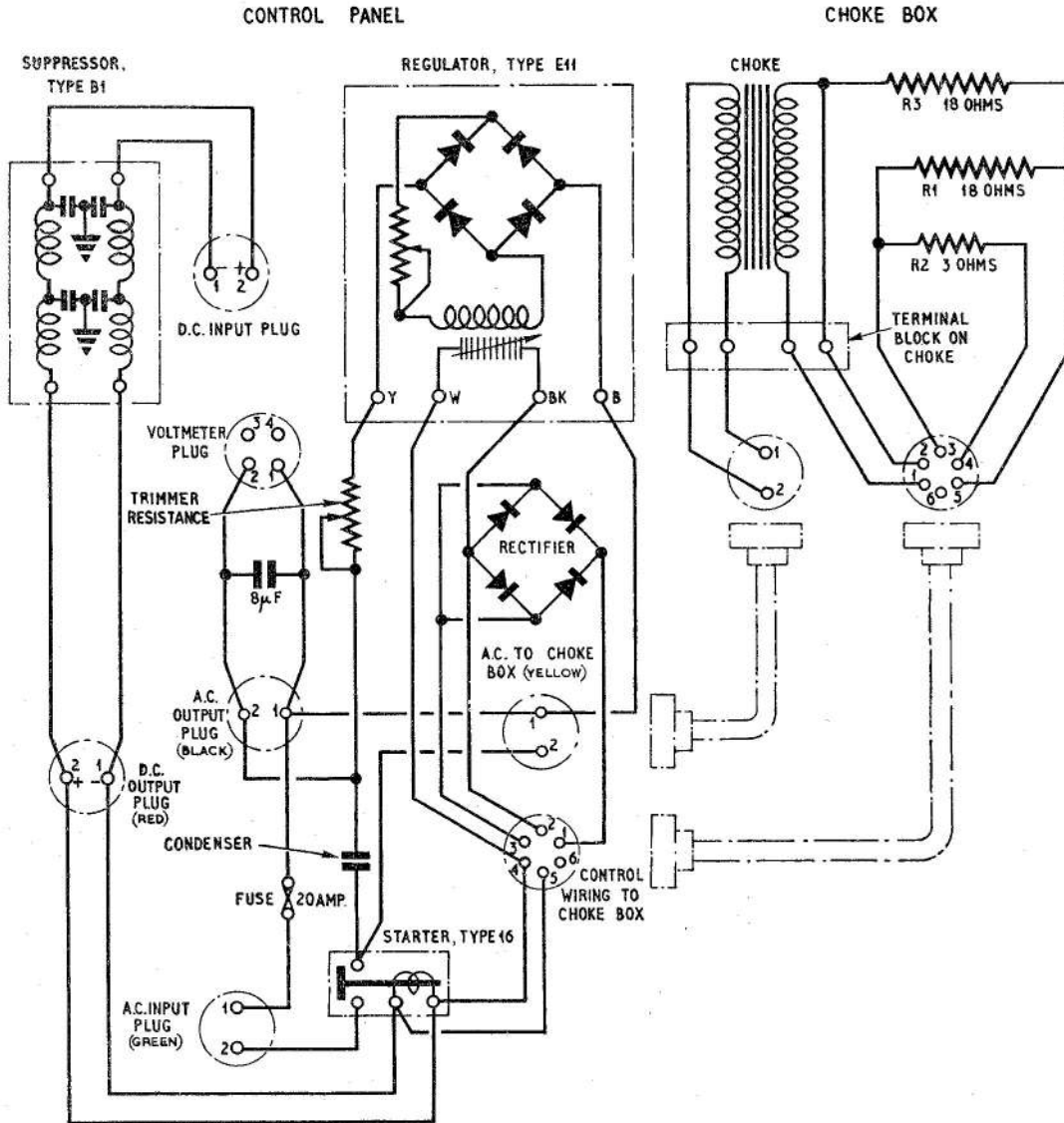

Fig. 1. Circuit diagram

RESTRICTED

Table 1
Plugs and sockets

No. of plug	Purpose	Plug		Corresponding socket		Colour code
		Type	Ref. No.	Type	Ref. No.	
1	Control wiring to choke box	W199	10H/392	W151, 152 153, or 154	10H/405, 406, 407, or 408	Plain
2	A.C. input	W204	10H/397	W165	10H/419	Green
3	D.C. input	W204	10H/397	W154	10H/	Plain
4	D.C. output	W204	10H/397	W165	10H/419	Red
5	Voltmeter	W198	10H/391	W149, 150 244, or 310	10H/403, 404, 1123 or 1599	Plain
6	A.C. output	W204	10H/397	W165	10H/419	Black
7	A.C. to choke box	W204	10H/397	W165	10H/419	Yellow
8	Control wiring from panel	W199	10H/392	W153, 154	10H/407, 408	Plain
9	A.C. input to choke box	W204	10H/397	W165	10H/419	Plain

slotted brackets which engage with hinged bolt and thumb nut assemblies carried on the front of the tray.

4. The plugs on the face of the panel are listed in Table 1. They are used for connecting the control panel to external circuits. The voltage regulator, Type E11, is described in Book 1, Sect. 1 of this publication, and the suppressor in A.P.4343C, Vol. 1, Book 3, Sect. 5.

Choke box

5. This comprises an iron-cored choke coil and three resistances, two of 18 and one of 3 ohms. The choke has two windings; one is connected across the a.c. output of the generator, Type UKX, and the other is supplied with d.c. via the rectifier and a bridge circuit consisting of the three resistance units and the carbon pile of the voltage regulator, Type E11, on the control panel. The iron core of the choke is finned for cooling purposes, and connections to the control panel are made by two plugs. The resistances are of the vitreous enamelled type and are supported in spring clip contacts secured to and insulated from the core of the choke

SERVICING

6. Little servicing should be required for the control panel. For information on the adjusting of individual items, reference should be made to the chapters indicated in the following paragraphs.

7. The starter, Type 16, is similar to the Type 15, which is covered in A.P.1186D, Vol. 1, Sect. 5, Chap. 2. That chapter includes instructions for various settings which may be necessary.

8. Access to the fuse box is obtained by loosening the two butterfly nuts securing the cover to the front of the panel. The cover carries a spare fuse, Type A.

9. Servicing instructions for the voltage regulator are given in Book 1, Sect. 1, of this publication, to which reference should be made as necessary.

Testing

10. For a test for a correct operation of the control panel, connections should be made as follows:

- (1) A.C. output plug to the a.c. terminals of a Type UKX generator.

RESTRICTED

(2) A.C. output plug, through switches, to non-inductive loads set for 12 amp. and 4 amp. respectively at 85 volts.

(3) Pins 1 and 2 of the voltmeter plug to a rectifier voltmeter suitable for frequencies up to 2,500 c/s.

(4) D.C. input plug to the d.c. terminals of the generator (pin 1 negative, pin 2 positive) through a switch.

(5) D.C. output plug to a d.c. voltmeter (pin 1 negative, pin 2 positive).

(6) The yellow 2-pole plug and the 6-pole plug on the panel are to be connected to the corresponding plugs on the choke box, pins with similar numbers being connected together.

(7) The d.c. terminals of the generator are to be connected through a switch to a load set for 60 amp. at 28 volts. The d.c. voltage is to be maintained at 28 volts for the voltage setting test.

11. With the generator running, close the switch between the generator and the d.c. input plug, and check that the relay closes satisfactorily as indicated by the reading of the a.c. voltmeter. Open the switch and check that the relay opens.

12. Tests should be made for correct regulation and stability, as laid down in Sect. 1 of this publication. The generator should be run on loads of (1) 12 amp. a.c., no load d.c., and (2) 4 amp. a.c., 60 amp. d.c.

RESTRICTED

This file was downloaded
from the RTFM Library.

Link: www.scottbouch.com/rtfm

Please see site for usage terms,
and more aircraft documents.

