

Chapter 10

MULTIPLE MASTER CONTROL IGNITION SWITCH, No. 3

LIST OF CONTENTS

	Para.	Description	Para.
Introduction	1		3

LIST OF ILLUSTRATIONS

	Fig.
Multiple master control ignition switch, No. 3	1

LEADING PARTICULARS

Multiple master control ignition switch No. 3		Stores Ref. 5CW/715
Dimensions of fixed plate	...	2.55 in. × 3.36 in.
Overall depth	...	3.18 in.
Weight	...	11½ oz.

Introduction

1. Ignition in an aero-engine is controlled by switches connected to the primary circuits of the magnetos. Each switch is arranged so that when it is closed it short-circuits the contact breaker of the magneto, and so prevents the high-tension voltage being generated in the secondary winding.

2. The switches are constructed in the normal manner so that the circuit is closed when the dolly is in the down position, but this position is designated OFF. Thus when the dolly is down the magneto is out of action, and when it is up the magneto is on. It should be borne in mind that if the switch is disconnected and the lead left open-circuited

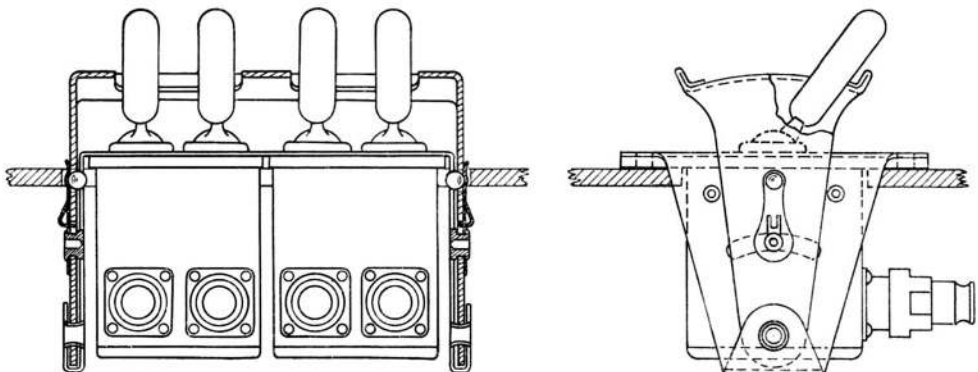

Fig. 1. Multiple master control ignition switch, No. 3

the magneto is on, and not off, and it is, therefore, advisable always to earth the lead when an ignition switch is removed.

DESCRIPTION

3. The multiple master control ignition switch, No. 3 (*fig. 1*) consists of two 2-way switchboxes (Stores Ref. 5CW/1540) assembled side by side, with a device by which all four switches can be operated simultaneously, and is used for controlling the magnetos of twin-engined aircraft. The switchboxes are identical with the 2-way ignition switchboxes, Type A, except that they are fitted with special elongated dollies to engage with a multiple handle.

4. The switchboxes and fixed plate of the multiple attachment are secured to the panel by the same screws, with the ends of the fixed plate projecting through slots in the panel and the multiple handle pivoting at the ends of these arms. The multiple handle has three positions. In the upper position all the magnetos are on, and in the lower position they are all off. In the central position each switch may be operated independently to any position, for testing or for any other special reason. The multiple handle will automatically take up this central position if any switch is operated independently. A spring loaded ball at each side holds the multiple handle in any of the three positions by engaging in pits in the arm of the fixed plate.

RESTRICTED

This file was downloaded
from the RTFM Library.

Link: www.scottbouch.com/rtfm

Please see site for usage terms,
and more aircraft documents.

