

Chapter 103

CHANGE-OVER SWITCH, TYPE 6-2N3219/2

LIST OF CONTENTS

	<i>Para.</i>		<i>Para.</i>
<i>Introduction</i>	1	Servicing	4
Description	2	<i>Millivolt drop test</i>	5
Operation	3	<i>Insulation resistance test</i>	6

LIST OF ILLUSTRATIONS

	<i>Fig.</i>		<i>Fig.</i>
<i>Change-over switch type 6-2N3219/2</i> ...	1	<i>Diagram of internal connections</i> ...	2

LEADING PARTICULARS

<i>Change-over switch</i>	Ref. No. 5CW/5878
<i>Voltage</i>	120V
<i>Overall dimensions (approx.)</i>	$7\frac{3}{4} \times 5 \times 5$ in.

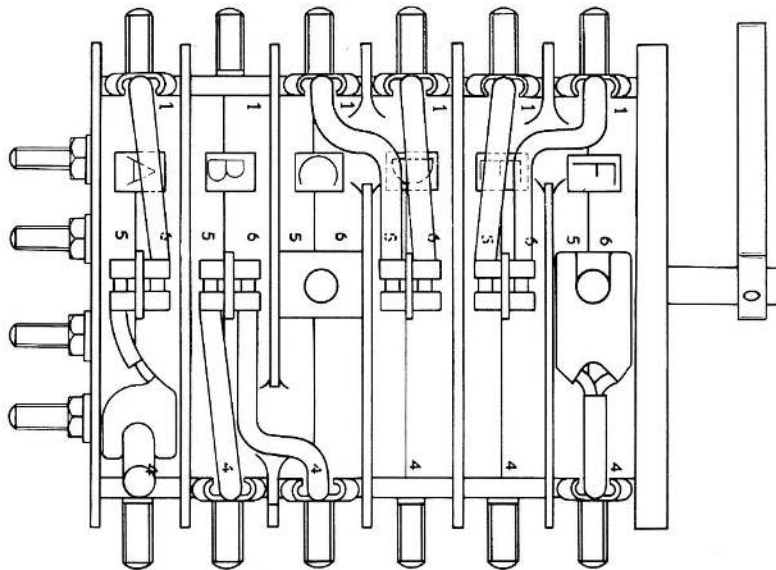

Fig. 1. Change-over switch type 6-2N3219/2

RESTRICTED

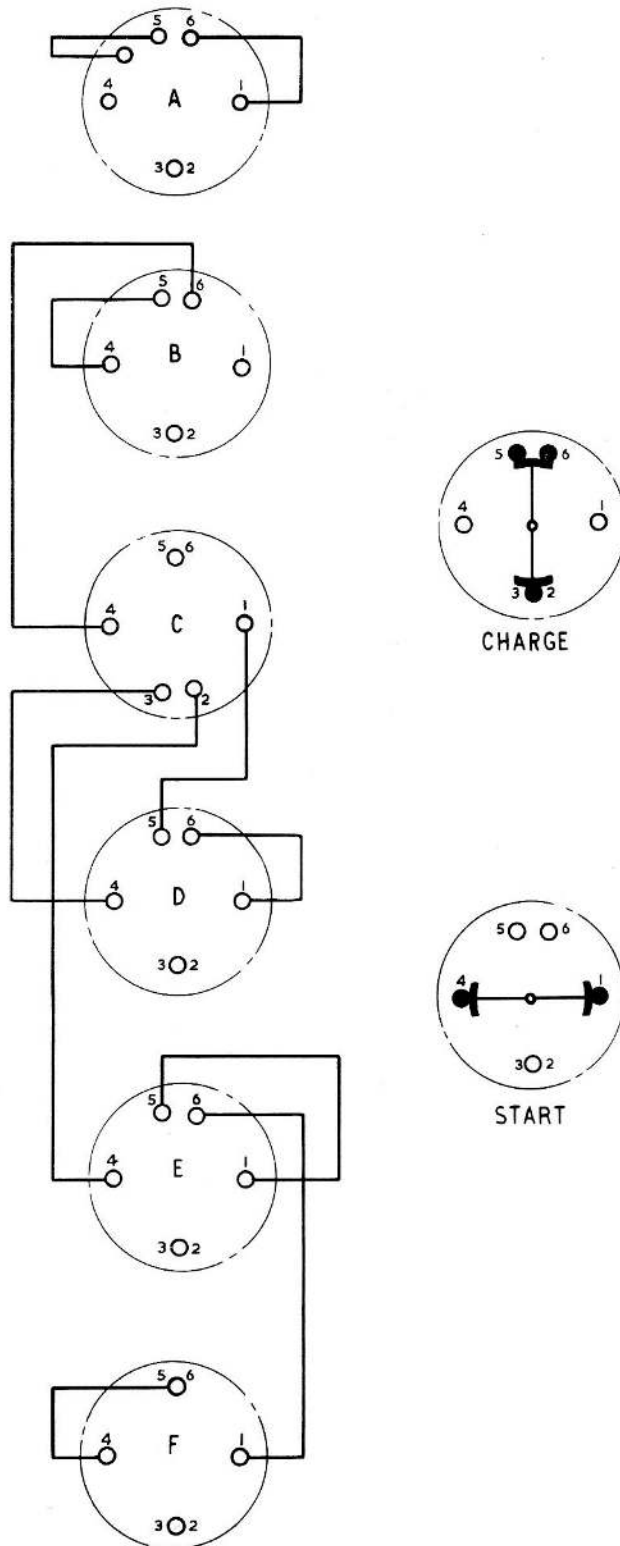

Fig. 2. Diagram of internal connections

RESTRICTED

Introduction

1. This is a two position rotary action switch, which is manually operated to select either INTERNAL START OR CHARGE. The switch has been designed to connect the batteries in an aircraft in series for starting and into two parallel groups for charging.

DESCRIPTION

2. The switch unit consists of six knife-switch sections assembled on a common shaft, each section being separately identified A to F (fig. 1). Fitted to one end of the shaft is a lever to operate the two positions of the switch, STARTING and CHARGING. The terminals for the electrical connections are shown in fig. 2, the terminal posts are $\frac{5}{16}$ in. B.S.F bolts and the cables are secured to these by stiff nuts. Section A is normally connected to a relay energizing circuit on the aircraft and sections B,C,D,E and F are connected to the aircraft batteries.

OPERATION

3. When the switch is in the CHARGE position terminals 2,3,5 and 6 are connected together. Operation of the switch to the START position will break the connection to terminals 2,3,5 and 6 and complete the connection between terminals 1 and 4. To ensure that the batteries are disconnected under no-load conditions, the contacts between terminals 5 and 6 of switch section A break before the contacts of the other five sections.

SERVICING

4. Examine the switch for damage, deterioration and security of attachment, also check the positive action of the switch.

Millivolt drop test

5. With the switch in the START position pass a current of 100 amps d.c. through terminals 1 and 4 on sections B,C,D,E and F and check that the millivolt drop does not exceed 10mV. Select the CHARGE position and pass a current of 100 amps through terminals 2 and 3, and 5 and 6 on section F, and check that the millivolt drop does not exceed 10mV. With the switch still in the CHARGE position, check that the millivolt drop does not exceed 50 millivolts when a current of 100 amps is flowing in the following:—

- (1) Terminals 5 and 6 on sections B,D and E.
- (2) Terminals 2 and 3 on section C.
- (3) Terminals 2 and 3 and 5 and 6 on sections B,C,D and E.

Insulation resistance test

6. Select START on the switch and using a 500 volt tester, measure the insulation resistance between terminals 2 and 3 on section C and between terminals 5 and 6 on sections A,B,D and F. A reading of not less than 5 megohms should be obtained.

RESTRICTED

This file was downloaded
from the RTFM Library.

Link: www.scottbouch.com/rtfm

Please see site for usage terms,
and more aircraft documents.

