

Chapter 14

DIMMER SWITCH, TYPE E

LIST OF CONTENTS

	<i>Para.</i>
<i>Introduction</i>	1
<i>Description</i>	3
<i>Servicing</i>	6

LIST OF ILLUSTRATIONS

	<i>Fig.</i>
<i>Dimmer switch, Type E</i>	1
<i>Construction of dimmer switch</i>	2

LEADING PARTICULARS

Dimmer switch, Type E	<i>Stores Ref.</i> 5CW/724
<i>Voltage</i>	24
<i>Resistance</i>	90 ohms
<i>Weight</i>	2.5 oz.
<i>Dimensions</i>	2.3 in. dia. × 1.85 in. high



Fig. 1. Dimmer switch, Type E

Introduction

1. The dimmer switch, Type E (*fig. 1*), is used to control cockpit lighting. It is undesirable for such lights to be brighter than necessary, since the brighter the light, the greater is the contrast with external light at night, and the greater is the danger of the position of the aircraft being betrayed on active service.

2. The dimmer switch consists of a variable resistance with an OFF position, and serves both as a switch and a control for the brightness of the lamp connected to it. The resistance is continuously variable, and the light may therefore be dimmed to any extent within the range provided.

(A.L.5, Dec. 54)

DESCRIPTION

3. The construction of the switch is shown in fig. 2. The resistance is wire-wound on a ring former; two separate resistance elements are wound on each former, and one end of each is connected to a terminal. Contact is made on the wire by two steel balls in the ends of a tube, which is held in a metal block turned by the knob. The insulation is removed from the wire along the track of the balls. The two points of contact are thus short-circuited, joining the two resistance elements in series, and the resistance between the terminals will depend on the position of the knob.

4. The ends of two screws form stops for the contact tube, and when the tube is in the extreme counter-clockwise position, against the stops, the balls are not in contact with the wire and the circuit is open. A small clockwise movement closes the circuit with all the resistance in series, and further move-

ment progressively decreases the resistance till none is in circuit. Thus the lamp connected in series with the dimmer switch will first light dimly, and will increase steadily to full brightness. The switch will normally be set in some intermediate position at which illumination is just sufficient.

5. The base, terminal plate, cover and knob are moulded in black insulating material. The base has three lugs with 0.125 in. dia. holes on a 2 in. pitch circle for mounting. The method of wiring is shown in the lower sketch of fig. 2. The centre terminal has no internal connection, but is used as a junction point for the direct connection from the lamp to the supply.

SERVICING

6. No servicing is required on this type of dimmer switch. A faulty switch should be replaced by a new one.

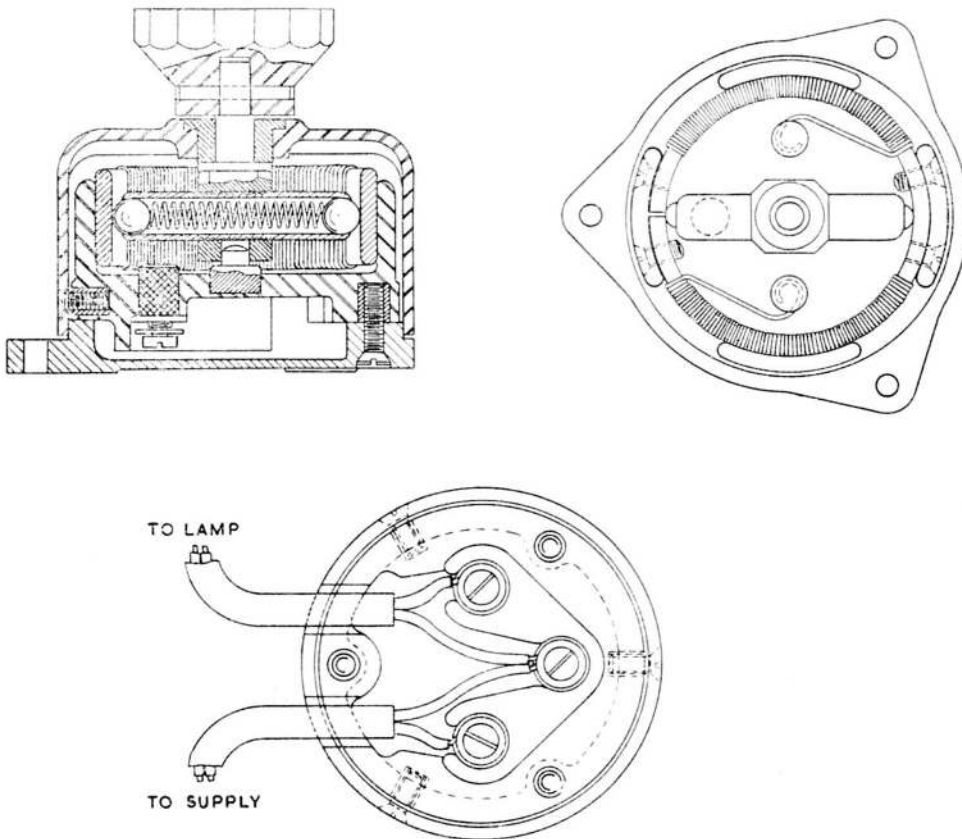

Fig. 2. Construction of dimmer switch

RESTRICTED

This file was downloaded
from the RTFM Library.
Link: www.scottbouch.com/rtfm

Please see site for usage terms,
and more aircraft documents.

