

Chapter 17

FIRE WARNING PUSH-SWITCH

LIST OF CONTENTS

	Para.		Para.
Introduction	1	Servicing	7
Description	3	Millivolt drop test	8
Operation	6	Insulation resistance test	9

LIST OF ILLUSTRATIONS

	Fig.		Fig.
Fire warning push-switch	1	Circuit diagram	3
Sectional view of switch	2		

LEADING PARTICULARS

Fire warning push-switch	Stores Ref. 5CW/6311
Current rating	5 amp.
Incorporating—	
Red cellastoid windows—	
F1	Stores Ref. 5CW/4528
F2	Stores Ref. 5CW/4529
F3	Stores Ref. 5CW/4530
F4	Stores Ref. 5CW/4531
Filament lamp (28V, 3·5W, clear)	Stores Ref. 5L/9951272
Overall dimensions—	
Length	3·7 in.
Diameter	1·406 in.
Mounting flange	1·53 in. x 1·53 in.
Weight	3 oz.

Introduction

1. The fire warning push-switch is connected in fire warning and extinguishing circuits to give visual indication of fire conditions, whereupon the appropriate extinguisher equipment can be initiated by depressing the push-switch.

2. The push-switch (Stores Ref. 5CW/6311) differs from the previous version (Stores Ref. 5CW/5763) only in having a modified return spring (Stores Ref. 5CW/6181); otherwise the two switches are identical. The push-switch (Stores Ref. 5CW/5763) was a modification of an earlier switch (Stores Ref. 5CW/4514), which had a pull-to-test facility incorporated, via terminals 3 and 6. The

modification deleted this facility, and fitted an internal packing washer to prevent the switch knob from being pulled.

DESCRIPTION

3. A general view of the switch is given in fig. 1, and a sectional view in fig. 2. The cover of the operating knob is marked with yellow diagonal stripes, and is fitted with one of four red cellastoid windows, as listed under Leading Particulars, to indicate the area concerned.

4. A lamp fitted inside the switch makes contact with terminals 6 and 7, the centre contact via a spring-loaded contact assembly to terminal 7. When the operating knob is depressed (*fig. 3*), the moving contacts bridge

(A.L.4, Jan. 58)

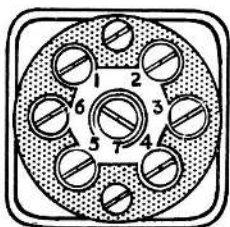
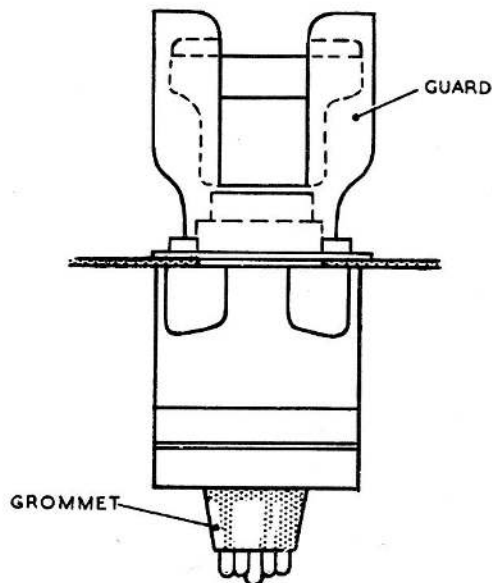
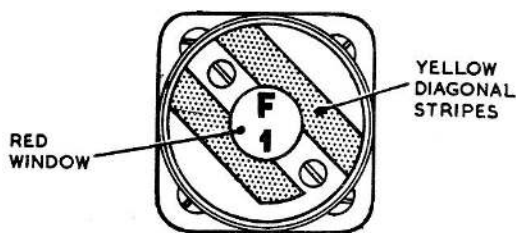

VIEW WITH COVER AND GROMMET REMOVED

Fig. 1. Fire warning push-switch

the fixed contacts 1 and 5, and 2 and 4, to energize the appropriate extinguisher contacts. When pressure is released, the switch returns to its unoperated position by spring pressure.

5. Electrical connection is made via a rubber grommet to screw type terminals in the base of the switch (fig. 1). Access to the terminals is gained by unscrewing the two screws securing the terminal cover.

OPERATION

6. Terminals 6 and 7 of the switch are connected in series with the appropriate detector, and terminals 1 and 5, and 2 and 4, in series with the fire extinguisher equipment. Operation of the detector lights the lamp in the knob of the switch; when the knob is depressed, terminals 1 and 5, and 2 and 4, are bridged to complete the extinguisher circuits.

SERVICING

7. The switch should be given a visual examination for freedom from damage and security of connections. The lamp in a switch installed in an aircraft may normally be tested by means of a remote test push-switch (Stores Ref. 5CW/5057) connected in series with the lamp; when the switch is closed, the lamp should light.

Millivolt drop test

8. With the switch removed from the aircraft, the millivolt drop between terminals

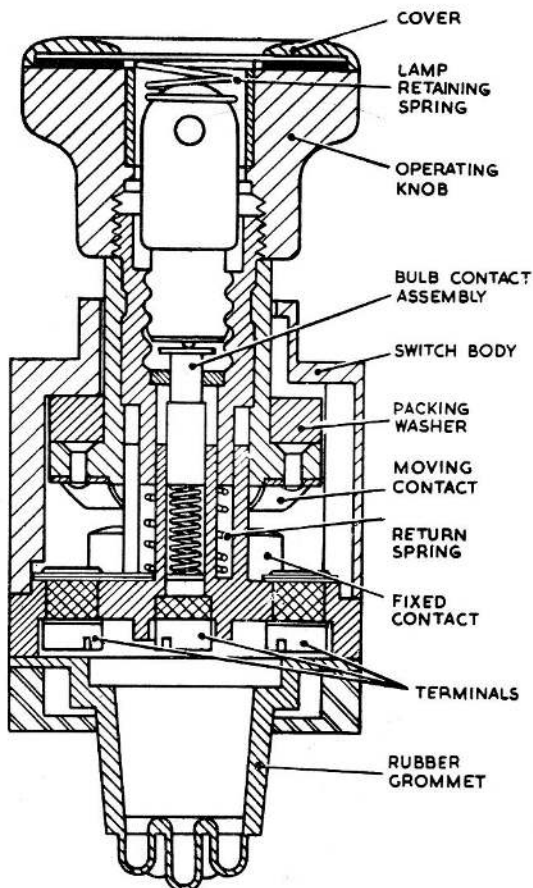

Fig. 2. Sectional view of switch

RESTRICTED

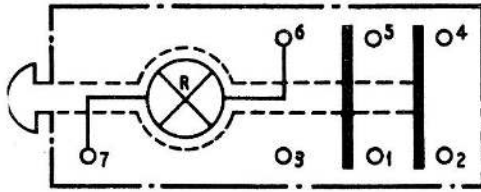

Fig. 3. Circuit diagram

1 and 5 and between terminals 2 and 4, taken separately with the knob fully depressed, must not exceed 50 millivolts with a current of 5 amp. flowing.

Insulation resistance test

9. Using a standard 250-volt insulation resistance tester, measure the insulation resistance between all terminals not normally connected together; the reading should not be less than 50 megohms.



This file was downloaded from the RTFM Library.

Link: www.scottbouch.com/rtfm

Please see site for usage terms, and more aircraft documents.

