

## Chapter 20

### MINIATURE SWITCHES, B.T.H., LHE.11-A SERIES

#### LIST OF CONTENTS

	Para.		Para.
<i>Introduction</i> ... ..	1	<i>Installation</i> ... ..	6
<i>Description</i> ... ..	2	<i>Servicing</i> ... ..	7
<i>Functioning</i> ... ..	4		

#### LIST OF TABLES

	Table		Table
<i>Switch data</i> ... ..	1	<i>Current rating</i> ... ..	2

#### LIST OF ILLUSTRATIONS

	Fig.		Fig.
<i>Miniature switch, B.T.H. Type LHE.11-A1/1</i> ... ..	1	<i>Section of miniature switch with detail of contact spring</i> ... ..	2

#### Introduction

1. All the switches of this series have a similar snap action movement and are housed in identical moulded cases. The difference between the various models occurs in the operating pressure on the push-buttons and the type of terminals which are

fitted. These differences are detailed in Table 1. The suffix to the type number is altered if the internal design is modified without affecting the operation or installation of the switch. All models have the same current rating, as detailed in Table 2, since the contact arrangements are identical.

**TABLE 1**  
**Switch data**

Type	Operating pressure	Terminals	Scores Ref.
LHE. 11—A1/1	16 oz. $\pm$ 4 oz.	Solder tags	5CW/4632
LHE. 11—A2/1	7 oz. $\pm$ 1 oz.	Solder tags	
LHE. 11—A5/1	16 oz. $\pm$ 4 oz.	Screw terminals	
LHE. 11—A6/1	7 oz. $\pm$ 1 oz.	Screw terminals	

**TABLE 2**  
**Current rating**  
**(amp. at 85 deg. C.)**

Volts	Inductive load		Non-inductive load	
	Sea level—10,000 ft.	50,000 ft.	Sea level—10,000 ft.	50,000 ft.
12 d.c.	10	10	10	10
24 d.c.	6	3.5	10	6
125 d.c.	0.20	0.20	0.20	0.20
250 d.c.	0.10	0.10	0.10	0.10
115 a.c.	10	10	10	10
230 a.c.	10	10	10	10

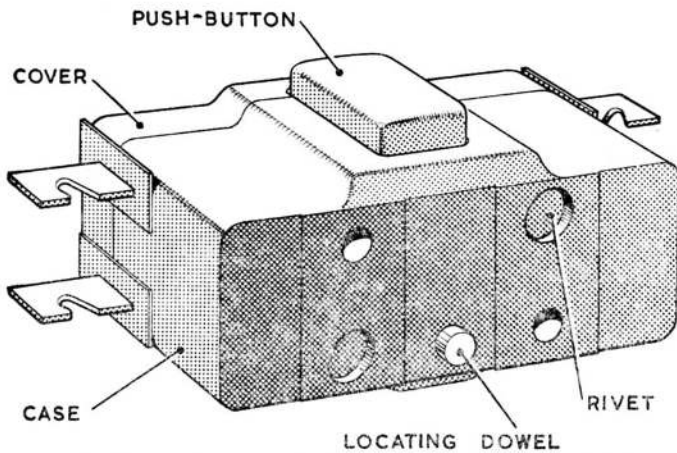

Fig. 1. Miniature switch, B.T.H. Type LHE.II-AI/I

#### DESCRIPTION

2. The operating mechanism of the switch is housed in a moulded Bakelite case (fig. 1) and held in position by a Bakelite cover secured to the main case by two rivets. The four fixed contacts (1, 2, 3 and 4 fig. 2) are welded directly to metal strips which project through slots in the ends of case and act as the terminals. The contact spring with a contact fixed at each end is the connecting link between the contacts (1) and (2) in the free position, as shown in fig. 2, or between contacts (3) and (4) when the switch is tripped by pressing the push-button.

3. The push-button itself is made of Bakelite and has pressed into it a guide shaft and two curved springs. The centre legs of the contact spring rest in recesses in the curved springs pressed into the push-button. The guide shaft carries a return spring which is under slight compression between a ring on the guide shaft and the inside of the case, when the switch is in the free position.

#### FUNCTIONING

4. When the push-button is depressed, the return spring is further compressed and the free ends of the centre legs of the contact spring move with the push-button and close towards the centre against the pressure of the two curved springs in the push-button. The contacts at the extreme ends of the contact spring will flip over when the free ends of the centre legs pass the neutral

point, that is when they pass below the level of the two main strips of the contact spring. On releasing the push-button the return spring will return the mechanism to the free position shown in fig. 2.

5. In either the free position or trip position, it is the force of the curved springs in the push-button, acting through the centre legs of the contact spring which produces the contact pressure between the contacts on the contact spring and the appropriate fixed contacts.

#### INSTALLATION

6. The switches are secured on installation by screws passing through two holes 0.094 in. diameter. The mounting face of the switches has a small projecting locating dowel (fig. 1) which should engage with a hole when installed correctly. On the other face of the switch, directly opposite to the dowel, there is a small recess which is designed to locate the dowel of similar switches if it is required to assemble more than one switch on the same securing screws.

#### SERVICING

7. Since the cover is permanently riveted to the case, the only servicing possible is to check the leads for security and verify that the switch is operating satisfactorily and the action is snappy when the push-button is depressed slowly. The switch should trip before the push-button has reached the limit of its travel, and re-set before the push-button has reached its free position.

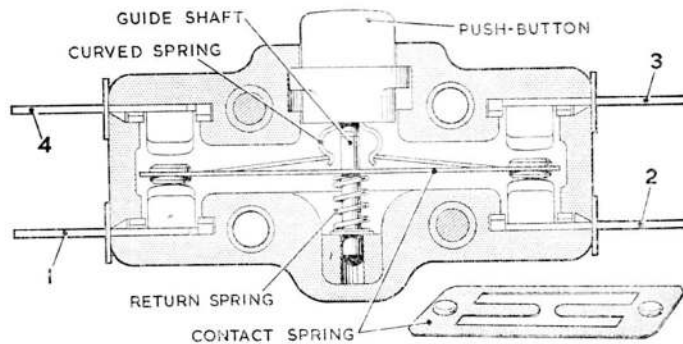

Fig. 2. Section of miniature switch with detail of contact spring

**RESTRICTED**

This file was downloaded  
from the RTFM Library.

Link: [www.scottbouch.com/rtfm](http://www.scottbouch.com/rtfm)

Please see site for usage terms,  
and more aircraft documents.



LIGHTNING MK. 1  
COVER PITOT HEAD  
EB2-88-511