

Chapter 21

TRIM SWITCH, WESTERN, TYPE TS 231

LIST OF CONTENTS

	<i>Para.</i>		<i>Para.</i>
<i>Introduction</i>	1	<i>Control knob and electrical connections</i>	5
Description		<i>Operation</i>	7
<i>Switches</i>	2	Installation	9
<i>Switch cover and riser assembly</i> ...	3	Servicing	10

LIST OF ILLUSTRATIONS

	<i>Fig.</i>		<i>Fig.</i>
<i>Trim switch, Type TS231</i>	1	<i>Internal wiring diagram</i>	3
<i>Sectional view of trim switch</i>	2		

LEADING PARTICULARS

Trim switch, Type TS213, Mk. 17	<i>Ref. No.</i> 5CW/6028
<i>Operating voltage</i>	28V d.c.
<i>Current rating</i>	5 amp.
<i>Temperature range</i>	+ 90 to - 55 deg. C
<i>Overall dimensions (in.)</i>	
<i>Length</i>	6.06
<i>Diameter of body</i>	2.5
<i>Mounting centres</i>	3 × 2.12
<i>Weight</i>	1.15 lb.

Introduction

1. The trim switch, Western, Type TS231, is illustrated in fig. 1, and is used for switching the aileron, elevator and rudder trimming actuators on and off. It is for use only with actuators that have a split series motor.

DESCRIPTION

Switches

2. The trim switch (fig. 2) consists of a hand control knob fastened to a shaft which has a universal coupling on its end. Movement of the shaft vertically or sideways moves a cruciform gate which operates two pairs of switches, one pair for aileron trimming and the other pair for elevator trimming. A rotary switch consisting of stud contacts

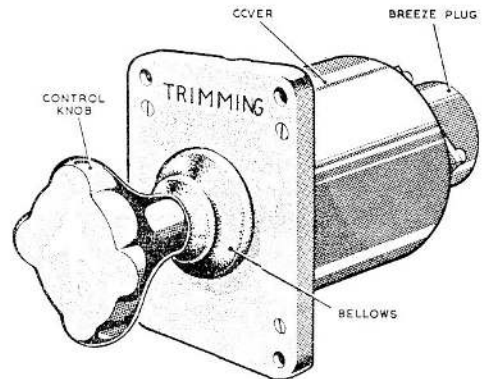

Fig. 1. Trim switch, Type TS231

RESTRICTED

secured in a contact plate, and wiper contacts attached to the end of the control shaft, is used for trimming the rudder. Rotary movement of the control knob turns the wiper contacts to engage with the stud contacts. All the switches are double-pole with silver contacts.

Switch cover and riser assembly

3. The switches are contained in a cover, the open end of which is covered by a top plate. Sealing washers at each end of the cover and a bellows near the control knob prevent the ingress of dust and oil. Distance tubes fastened to a base plate at the bottom of the cover, carry the micro switches and the top plate.

4. A riser assembly, consisting of steel balls held in a fixed plate with a spring-loaded bent plate contacting the balls, is used to return the control knob to the neutral position when rotary operating pressure is released. Spring-loaded plungers in the top plate automatically return the knob to the neutral position when sideways or vertical operating pressure is released.

Control knob and electrical connections

5. A plan view of an aircraft is painted on the face of the control knob, and when the knob is operated this image indicates the resulting movement that the aircraft will

make; e.g., when the control knob is turned in a clockwise direction the nose of the image turns to starboard and this is the direction in which the nose of the aircraft will turn.

6. The internal wiring of the switch is brought out to a waterproof, 14-pole plug, Type C (Ref. No. 5X/6091), on the end of the switch. A wiring diagram (fig. 3) illustrates the connections to the micro switches, rotary switch and plug.

Operation

7. Operation of the switch control knob is rotary, sideways, up and down, to suit the required trimming movement of the aircraft. When the control knob is turned in a clockwise direction, the rudder is trimmed to turn the nose of the aircraft to starboard, and when the knob is turned anti-clockwise the rudder is trimmed to turn the nose of the aircraft to port.

8. Trimming of the aileron is brought about by pushing the control knob over to the right or to the left, movement to the right trimming the port wing up, and movement to the left trimming the starboard wing up. The elevators are trimmed by upward and downward movement of the control knob which causes the nose of the aircraft to be trimmed downward and upwards respectively. When

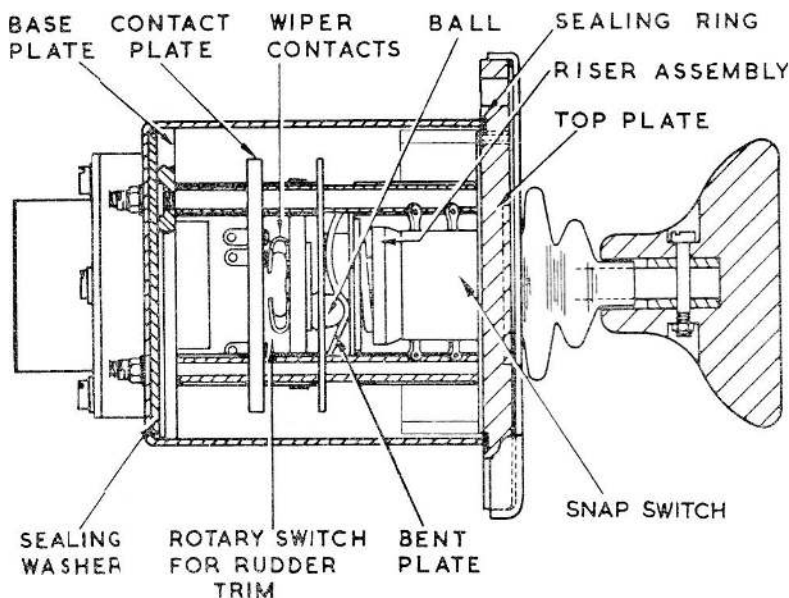

Fig. 2. Sectional view of trim switch

RESTRICTED

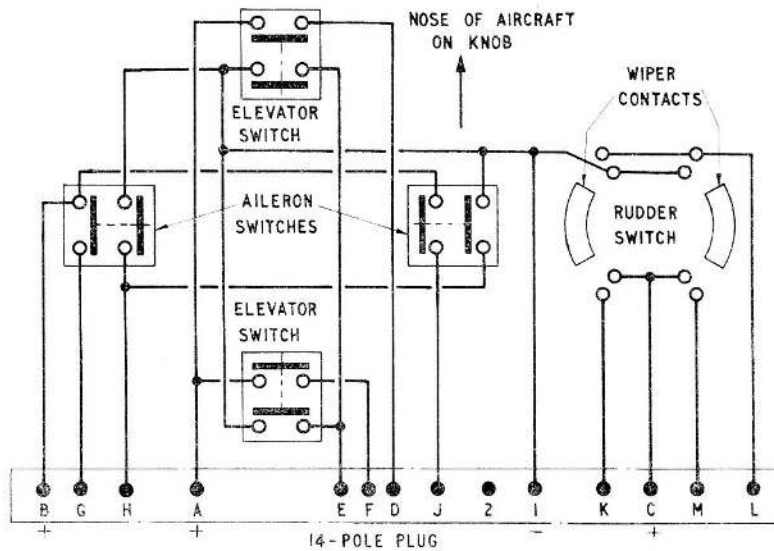

Fig. 3. Internal wiring diagram

released, the control knob returns automatically to its neutral position in all instances. The rudder and aileron or rudder and elevator can be trimmed together but the aileron and elevator cannot be trimmed simultaneously.

INSTALLATION

9. The switch must be mounted so that the image of the aircraft has its nose pointing upwards. The method of securing is by screws or studs through the four holes in the top plate.

SERVICING

10. To gain access to the inside of the switch, remove the seal, nuts and washers from the end studs, and draw the cover away from the switch. If the contacts of the rotary switch are dirty, clean them with a piece of non-fluffy rag moistened with lead-free gasoline, then lightly smear the rotary switch contacts, balls and bent plate with protective PX-7 (Ref. No. 34B/9100487).

Ensure that the connections to the switches are securely soldered.

11. When the control knob is moved to each position, the smoothness of operation and return under spring pressure with no tendency to stick should be confirmed.

12. The millivolt drop on each individual circuit when carrying 5 amp., should not exceed 20 millivolt.

13. Using a 250V insulation resistance tester, check the insulation resistance between the terminals of any two separate circuits, and between all the terminals connected together and the frame of the switch. A reading of not less than 20 megohms should be obtained for each test.

14. On completion of the servicing, refit the cover, secure it by the washers and nuts and attach the seal by means of a piece of 24 S.W.G. locking wire.

RESTRICTED

This file was downloaded
from the RTFM Library.

Link: www.scottbouch.com/rtfm

Please see site for usage terms,
and more aircraft documents.

