

Chapter 22**PUSH-SWITCHES, DOWTY 1210Y SERIES
(1211Y, 1212Y, 1213Y)****LIST OF CONTENTS**

	<i>Para.</i>		<i>Para.</i>
<i>Introduction</i>	1	Installation	20
Description	6	<i>Compass interference</i>	23
<i>Push-switch, 1212Y, Mk. 5</i>	9	Servicing	25
<i>Electrical connections</i>	13	Testing	26
<i>Principle of operation</i>	15	<i>Insulation resistance test</i>	30

LIST OF ILLUSTRATIONS

	<i>Fig.</i>		<i>Fig.</i>
<i>General view of 1212Y, Mk. 5 switch</i>	1	<i>Installation details</i>	4
<i>General view of 1213Y, Mk. 5 switch</i>	2	<i>Contact arrangements (per button)</i>	5
<i>Sectional view of 1212Y, Mk. 5 switch</i>	3	<i>Switch details</i>	6

LIST OF TABLES

	<i>Table</i>
<i>Switch details</i>	1

LEADING PARTICULARS

Push-button switches, 1210Y series	<i>Ref. No. (see Table 1)</i>
<i>Contact operating voltage</i>	28V d.c.
<i>Coil operating voltage</i>	28V d.c. to 16V d.c. min.
<i>Coil current consumption</i>	70 milliamps at 28V d.c. 20 deg. C
<i>Mounting attitude</i>	unrestricted
<i>Operating altitude</i>	sea level to 60,000 ft.
<i>Safe distance from compass</i>	12 in. for max. error of 1 deg.

RESTRICTED

LEADING PARTICULARS—continued

Operating loads and travel

1211 Y (single spring- loaded button)	}	Load to operate push button ...	5 lb. for positive closing of contacts
		Release load	0.5 lb. max. for positive opening of contacts
		Load on push-button to override safety lock	35 to 45 lb. max.
		Load current per contact set ...	5 amp. resistive, 1 amp. inductive at 0.25 Henry
		Millivolt drop	50 MV max. for current of 1 amp.
		Special electrical feature ...	Electro-magnetic release for push-button lock

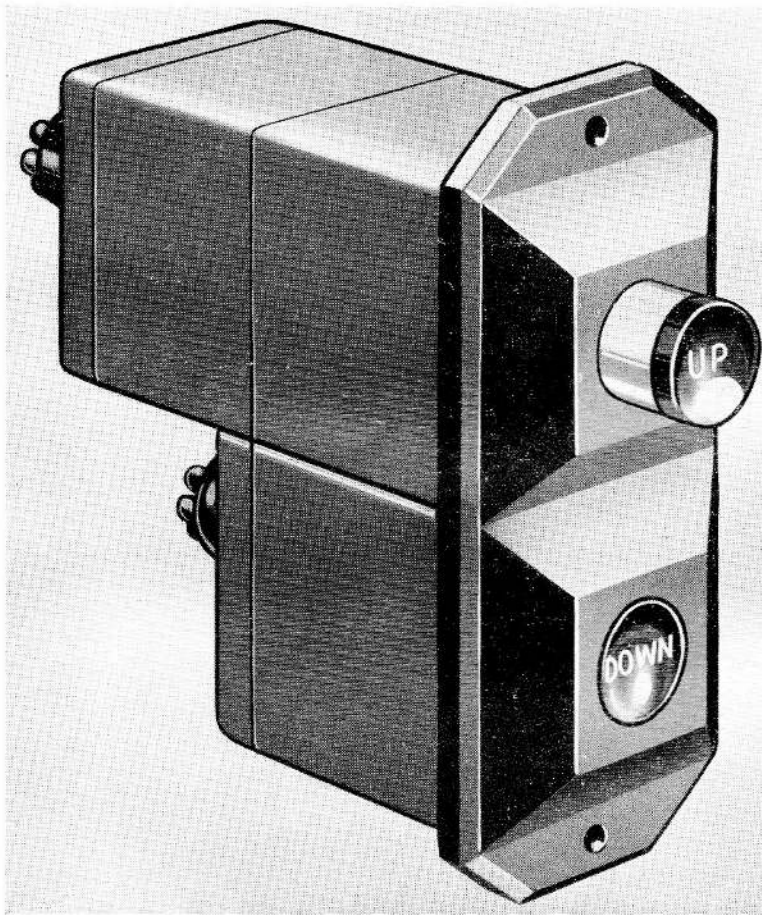

Fig. 1. General view of 1212Y, Mk. 5 switch

RESTRICTED

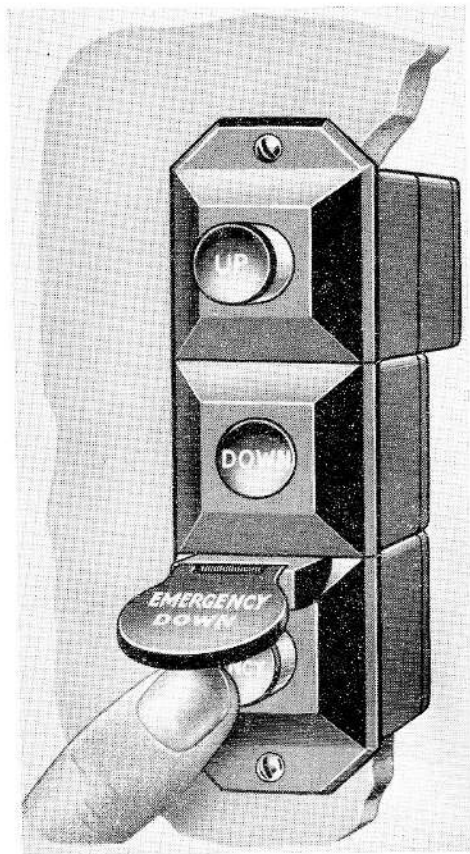

Fig. 2. General view of 1213Y, Mk. 5 switch

Introduction

1. The Dowty type 1210Y series covers a wide range of push button switches, all being of basically similar design and varying from the single button type, up to as many as eight buttons.

2. The switch type number is governed by the number of buttons fitted and alters the unit figure of the type number, e.g. 1211Y switch is fitted with a single button, 1212Y with two buttons and 1213Y with three buttons.

3. The switch mark number identifies the physical details of the switch, i.e. button colour and engraving, etc.

4. The switches more generally used within this range are the 1212Y, Mk. 5 and 1213Y, Mk. 5 types.

5. The description of the switches in this chapter and the general views in Fig. 1 and 2 will, in general, cover the 1210Y switch range.

DESCRIPTION

6. The 1212Y, Mk. 5 switch is a two-button double pole unit, while the 1213Y, Mk. 5 switch is a three-button unit; both types are fitted with an electro-magnetically released lock, which has a mechanical override for emergency use.

7. The switch mechanism is housed in a strong moulded plastic case, the front cover of which, carries the drilled flange for the fixing bolts. The lock mechanism is housed in a similar type of case, which forms an extension, to the rear of the switch mechanism case.

8. The 1210Y series of switches are so designed that each button is interlocked with the other, so that only one button may be 'IN' at a time. As a button is depressed, the movement mechanically ejects the button already 'IN', this feature makes double selection impossible.

Push-switch, 1212Y, Mk. 5

9. A sectional view of the 1212Y, Mk. 5 push-button switch is shown in figure 3. Each button assembly (11) incorporates a wheel (10) free to rotate on a spindle (5); on each protruding end of which is a contact roller (13) which bridge contact blades (14), arranged in pairs, one pair each side of the button, and connected to terminal inserts in a terminal block (17) which is housed in a phenolic plastic case (12) and is bolted to internal support plates (7).

10. Each section has its own terminal block and button mechanism, the separate sections being fitted together to make up the multi-button switches (fig. 6). Again referring to figure 3, a slider (19) is accommodated between each section of the multi-button assemblies. A rubber cone (9) seals the button movement and protects the electrical parts. In later models of the 1212Y and 1213Y switches, identified by the suffix 'D' following the mark number, an improved snap-action feel is imparted to the button by a spring-loaded indexing ball.

RESTRICTED

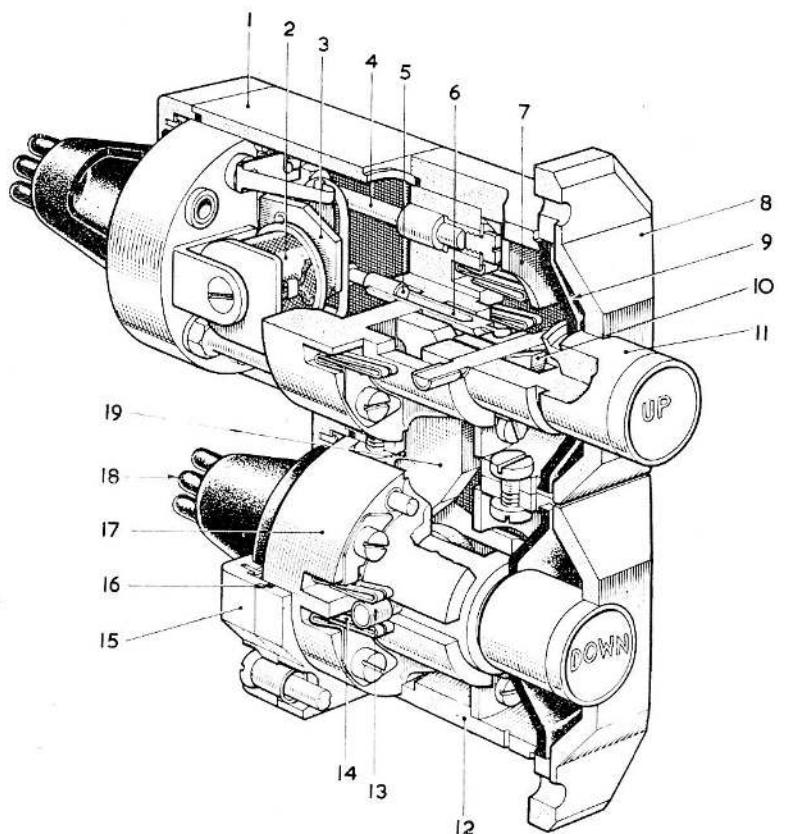

- | | |
|-------------------|--------------------|
| 1 CASE, TOP | 10 WHEEL |
| 2 COIL | 11 BUTTON ASSEMBLY |
| 3 ARMATURE | 12 CASE, LOWER |
| 4 PILLAR | 13 CONTACT ROLLER |
| 5 SPINDLE | 14 CONTACT BLADE |
| 6 OVERRIDE SLEEVE | 15 TERMINAL COVER |
| 7 SUPPORT PLATE | 16 SEALING RING |
| 8 COVER | 17 TERMINAL BLOCK |
| 9 CONE, RUBBER | 18 GROMMET |
| | 19 SLIDER |

Fig. 3. Sectional view of 1212Y, Mk. 5 switch

11. The lock section incorporates a coil (2), an armature (3), pillars (4), a spindle (5), which is adjustable, and an override sleeve (6). A phenolic plastic case (1) encloses the lock section and is sealed at both ends by sealing rings (16). A terminal cover (15), complete with grommet (18) for anchoring the external wiring leads, is provided for both sections.

12. A wide range of contact arrangements of up to four terminals per button is available

(fig. 5). The contact rating is 5 amperes at 28V d.c., and minimum internal resistance is ensured by silver contact surfaces.

Electrical connections

13. The electrical connections to the switch contacts and to the button release are made by 6 B.A. terminal screws; these screws are carried by a moulded terminal block which fits inside the free end of the switch mechanism case (sections without lock) or, inside the free end of the lock mechanism

RESTRICTED

case (sections with lock). In both cases the screws are shrouded in recesses which will accept 0.22 in. diameter terminal tags.

14. Terminals 5 and 6 appear only on sections incorporating the locking mechanism. Lock sections may be fitted with a mu-metal shield to reduce compass interference.

Principle of operation

15. Consider a two-button switch with the 'UP' button in. Pressing the 'DOWN' button, forces it into the unit through a guide, until its contact rollers bridge the contact blades. At the same time, the pressure exerted by a wheel housed in the button shank, on to a slider, forces it into the opposing half of the switch. The pressure is thus transferred to a similar wheel on the 'UP' side, causing the wheel to ride up the cam face at the other end of the slider, ejecting the 'UP' button (fig. 3).

16. To prevent inadvertent 'UP' selection, a lock section is incorporated, so that the lower end of a hollow sleeve, contacts a stop spring, preventing the button entering and making electrical contact.

17. With the 1212Y, Mk. 5 unit, provision is made to override this safety device with the magnet de-energized (for emergency operation) at a load of 40 ± 5 lb.

Note . . .

The 1212Y, Mk. 10 unit has a positive lock, so that the override action does not apply, and in this case a load of 60 lb. must not be exceeded.

18. To release the lock, a magnet within the switch is energized by the closing of an external switch or relay, the push-button switch may then be operated normally.

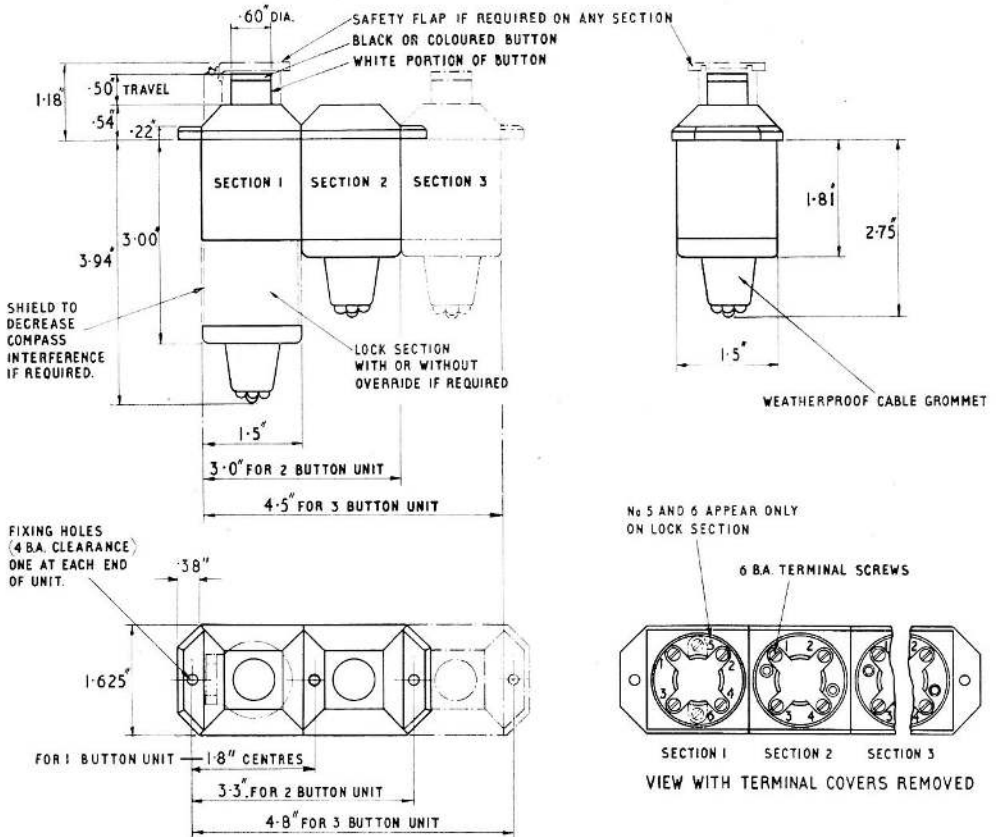

Fig. 4. Installation details

RESTRICTED

19. The operation of the 1213Y, Mk. 5 switch is as described in the preceding paragraphs, with the exceptions that a third button is introduced and that the button interlock comprises two sliders; basically the functioning is the same for all push-switches within the 1210Y range.

INSTALLATION

20. The unit is mounted from the front of the panel and is secured by two 4 B.A., or 6 UN.C. bolts.

21. For the terminal connections (contact arrangement fig. 5) the terminal screws fitted to the switch are 6 B.A. and the terminal block recesses for the screw heads will take 0.22 in. diameter crimped terminal tags. No. 5 and 6 terminals appear on lock sections only (fig. 4).

22. Before installing a switch, reference should be made to the relevant aircraft wiring diagrams, to ensure that no action taken in connecting the switch, or subsequent testing, will inadvertently operate any associated circuit in the aircraft.

Compass interference

23. The minimum safe distance of the switch from a magnetic compass for a maximum error of one degree is 12 in., this may be reduced by the fitting of a mu-metal shield to the electro-magnetic lock release section of the switch.

24. A safety flap (fig. 2) may be fitted over any button; if a more certain safeguard is needed an electrically released lock is available on any one button, preventing depression of the button under controllable conditions.

SERVICING

25. The switch should be inspected periodically for signs of corrosion and damage, also security of mounting and electrical connections; at the same time the switch should be cleaned.

TESTING

26. Test the buttons in each switch section; see contact arrangements (fig. 5) and switch details (fig. 6).

27. The majority of switches are supplied with removable links in the terminal housing, connecting terminals 1-3 and 2-4 respectively. If the switches are used with the links in place, it is sufficient to test at terminals 1 and 2 in each section.

28. The following test should be carried out as described.

(1) Test the operating button for free travel; this should not exceed 0.14 in.

(2) Lock section without emergency override: with the lock release solenoid not energized, the operating button of this section should not depress when a force of 45 lb. is applied to it. The button must not be subjected to a force exceeding 60 lb., or damage to the switch mechanism will result.

(3) Lock section with emergency override: with the lock release solenoid not energized the operating button should not depress until a force of 35 to 45 lb. is applied to it.

29. The switch is designed for a life of 10 years, or 30,000 flying hours; should the switch, or its lock release fail to operate, the signal circuits should be tested; if these are satisfactory a new switch must be fitted.

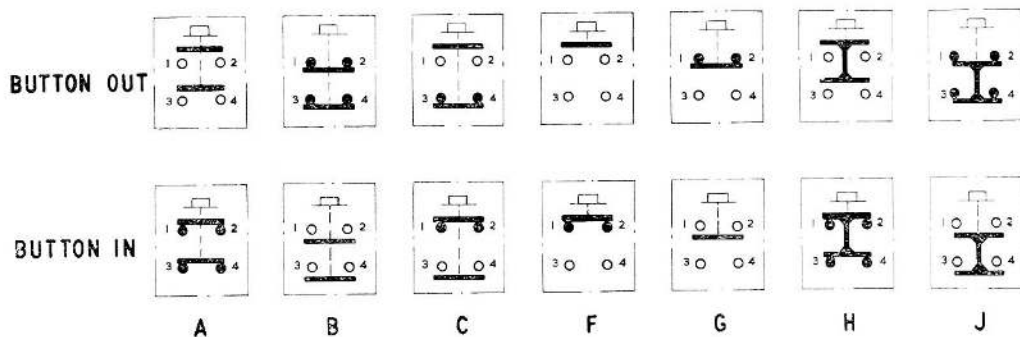

Fig. 5. Contact arrangements (per button)

RESTRICTED

SWITCH	MK	LOCK SECTIONS	SAFETY FLAPS	CONTACT ARRGT.	BUTTONS ENGRAVING & COLOURS BLACK UNLESS OTHERWISE STATED	SWITCH	MK	LOCK SECTIONS	SAFETY FLAPS	CONTACT ARRGT.	BUTTONS ENGRAVING & COLOURS BLACK UNLESS OTHERWISE STATED
1211 Y	1	WITH OVERRIDE	-	'A'	UP	1212 Y	16	SECTION I WITH OVERRIDE	SECTIONS 1 & 2	BOTH SECTIONS 'A'	UP DOWN
1212 Y	1	-	-	BOTH SECTIONS 'A'	FOLD SPREAD	..	17	SECTION I WITH OVERRIDE	SECTION 1	ALL SECTIONS 'A'	UP DOWN GREY
..	2	-	SECTION I	BOTH SECTIONS 'A'	FOLD SPREAD	..	18	-	-	ALL SECTIONS 'A'	OFF ON RED RED
..	3	-	SECTION I	BOTH SECTIONS 'A'	UP DOWN	1213 Y	1	-	-	ALL SECTIONS 'A'	UP MAX LIFT RED DOWN
..	4	-	-	BOTH SECTIONS 'A'	STOP START RED RED	..	2	-	-	ALL SECTIONS 'A'	ON CSU OFF RED RED
..	5	SECTION I WITH OVERRIDE	-	BOTH SECTIONS 'A'	UP DOWN	..	3	-	-	ALL SECTIONS 'A'	UP MID DOWN
..	6	-	-	BOTH SECTIONS 'A'	OPEN SHUT	..	4	-	-	ALL SECTIONS 'A'	UP OFF DOWN
..	8	SECTION I WITH OVERRIDE	-	BOTH SECTIONS 'A'	A.P. A.B.A.	1213 Y	5	SECTION I WITH OVERRIDE	SECTION 3	ALL SECTIONS 'A'	UP DOWN EM DOWN RED BUTTON
..	9	SECTION I WITHOUT OVERRIDE	SECTIONS 1 & 2	BOTH SECTIONS 'A'	UP DOWN	1213 Y	6	SECTION I WITHOUT OVERRIDE	SECTIONS 1, 2 & 3	ALL SECTIONS 'A'	UP DOWN EM DOWN RED BUTTON
..	10	SECTION I WITHOUT OVERRIDE	-	BOTH SECTIONS 'A'	UP DOWN	1213 Y	7	SECTION I WITH OVERRIDE	SECTION 3	SECTIONS 1 & 2 - 'A' SECTION 3 - 'C'	UP DOWN EM DOWN RED BUTTON
..	11	-	-	BOTH SECTIONS 'A'	UP DOWN	1213 Y	8	-	-	ALL SECTIONS 'A'	UP DOWN
..	12	-	SECTION I	BOTH SECTIONS 'A'	UP DOWN	1213 Y	9	-	-	ALL SECTIONS 'A'	UP DOWN
..	13	SECTION I WITH OVERRIDE	SECTIONS 1 & 2	BOTH SECTIONS 'A'	UP DOWN	1213 Y	10	SECTION I WITH OVERRIDE	SECTIONS 1 & 3	ALL SECTIONS 'A'	UP DOWN EM DOWN RED BUTTON
..	14	-	-	ALL SECTIONS 'A'	A.P. GREEN RED	1213 Y	11	-	SECTIONS 1 & 3	ALL SECTIONS 'A'	UP DOWN EM DOWN RED BUTTON
..	15	SECTION I WITH OVERRIDE	-	BOTH SECTIONS 'C'	UP DOWN RED	1213 Y	12	-	SECTION 3	ALL SECTIONS 'C'	UP DOWN EM STOP RED BUTTON

Fig. 6. Switch details

Insulation resistance test

Note . . .

When carrying out an insulation resistance test, do not apply the test voltage between terminals 5 and 6, as this will damage the lock release solenoid coil.

30. Dependent upon the position of the switch button, measure the insulation resistance between terminals 1, 2, 3 and 4 for non-contact, also between the same terminals and the frame; the readings in each case should not be less than 5 megohms, see figures 5 and 6 for contact arrangements and switch details.

RESTRICTED

TABLE 1
Switch details

Type of switch	Ref. No. 5CW/	Application	Weight in oz.
1211Y, Mk. 1	6497	U/C switch, spring return	6.4
1211Y, Mk. 1D	6980	" " " "	6.4
1211Y, Mk. 2	8874	" " " "	6.4
1212Y, Mk. 1		Wing folding	7.1
1212Y, Mk. 2		" "	7.8
1212Y, Mk. 3	4180	U/C	7.8
1212Y, Mk. 4	4248	Test rig	7.1
1212Y, Mk. 4D	6981	" "	7.1
1212Y, Mk. 5	4212	U/C	9.8
1212Y, Mk. 5D	6982	U/C	9.8
1212Y, Mk. 6	4213	Bomb doors	7.1
1212Y, Mk. 8		U/C (spanish)	9.8
1212Y, Mk. 9		"	11.4
1212Y, Mk. 10		"	7.1
1212Y, Mk. 12	4546	"	7.8
1212Y, Mk. 13		"	11.4
1212Y, Mk. 4			7.1
1212Y, Mk. 15		(links are omitted)	9.8
1212Y, Mk. 16		Both flaps engraved red	11.0
1212Y, Mk. 17		U/C	10.5
1212Y, Mk. 18			7.1
1213Y, Mk. 1		Flap operation	11.0
1213Y, Mk. 2		Propeller braking	11.0
1213Y, Mk. 3		Dive recovery	11.0
1213Y, Mk. 4		Test rig	11.0
1213Y, Mk. 5		U/C	14.4
1213Y, Mk. 6		"	15.8
1213Y, Mk. 7		"	15.8
		(links supplied separately for section 3)	14.4
1213Y, Mk. 8		No. 3 section has spring return button	11.0
1213Y, Mk. 9			11.0
1213Y, Mk. 10		U/C	15.1
1213Y, Mk. 11		"	12.4
1213Y, Mk. 12		(links are omitted)	11.7

The Mark No. followed by suffix "D" denotes ball detent action on the button movement.
U/C denotes undercarriage.

RESTRICTED

This file was downloaded
from the RTFM Library.

Link: www.scottbouch.com/rtfm

Please see site for usage terms,
and more aircraft documents.

