

Chapter 3

PUSH-SWITCHES

LIST OF CONTENTS

	<i>Para.</i>		<i>Para.</i>
<i>Introduction</i>	1	<i>Single-pole switches, Type B, No. 1, No. 2 and No. 3</i>	4
Description		<i>Starting switch</i>	7
<i>Double-pole switch, Type B</i>	2	<i>Switch, Type P4/2</i>	9
		Servicing	11

LIST OF ILLUSTRATIONS

	<i>Fig.</i>		<i>Fig.</i>
<i>Sectional view of double-pole switch, Type B</i>	1	<i>Switch, Type P4/2</i>	3
<i>Sectional view of starting switch</i>	2	<i>Sectional view of switch, Type P4/2</i>	4

LIST OF APPENDICES

	<i>App.</i>
<i>Spring covers for push-switches</i>	1

LEADING PARTICULARS

Double-pole, Type B	<i>Ref. No. 5CW/540</i>
<i>Dimensions of mounting flange</i>	1.25 in. × 1.25 in.
<i>Overall depth</i>	1.9 in.
<i>Weight</i>	1 $\frac{3}{8}$ oz.
Single-pole, Type B, No. 1	<i>Ref. No. 5CW/898</i>
<i>Dimensions of mounting flange</i>	1.25 in. × 1.25 in.
<i>Overall depth</i>	2 in.
<i>Weight</i>	1 $\frac{1}{4}$ oz.
Single-pole, Type B, No. 2	<i>Ref. No. 5CW/2091</i>
<i>Dimensions of mounting flange</i>	1.25 in. × 1.25 in.
<i>Overall depth</i>	2 in.
<i>Weight</i>	1 $\frac{1}{4}$ oz.
◀ Single-pole, Type B, No. 3	<i>Ref. No. 5CW/3821</i>
<i>Dimensions of mounting flange</i>	1.25 in. × 1.25 in.
<i>Overall depth</i>	2.07 in. ▶
Starting switch	<i>Ref. No. 5CW/695</i>
<i>Dimensions of mounting flange</i>	2.25 in. × 2.25 in.
<i>Overall depth</i>	2.65 in.
<i>Weight</i>	6.5 oz.
Type P4/2	<i>Ref. No. 5CW/4061</i>
<i>Overall diameter</i>	1 $\frac{7}{8}$ in.
<i>Overall depth</i>	2 $\frac{3}{4}$ in.
<i>Weight</i>	4 oz.

RESTRICTED

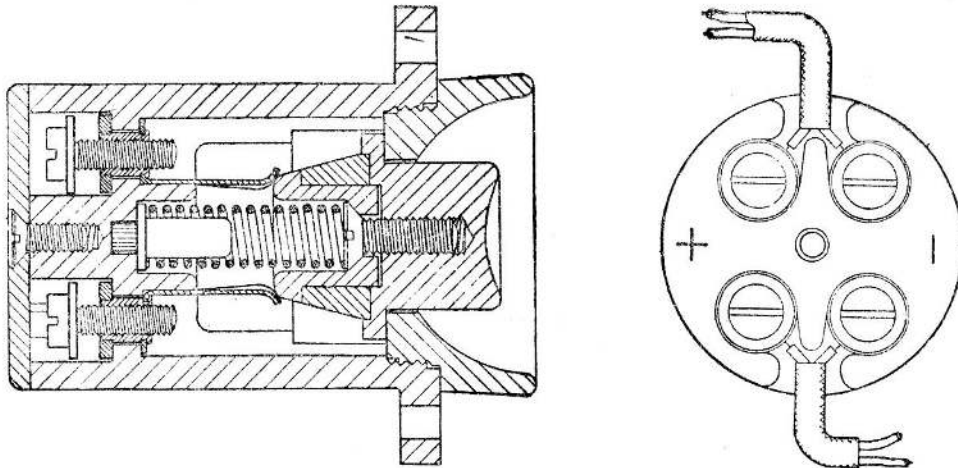

Fig. 1. Sectional view of double-pole switch, Type B

Introduction

1. This chapter gives details of various types of push-switch which are in use in the Service. Dimensional details will be found under Leading Particulars.

DESCRIPTION

Double-pole switch, Type B

2. This is a push-switch for use in circuits where the current does not exceed 5 amp.; it is normally open, and spring-loaded to return to the open position after operation.

3. The mechanism of the switch is shown in fig. 1. There are four terminals, two negative and two positive, each connected to a leaf-spring contact. Two bridging pieces are mounted on the plunger, one to bridge the positive terminals and the other the negative terminals.

Single-pole switches, Type B, No. 1, No. 2 and No. 3

4. The push-switch, Type B, No. 1, is a single-pole, push-to-make switch for use in circuits where the current does not exceed 5 amp. The two terminals are bridged similarly to the pairs of terminals in the double-pole push-switch, Type B, illustrated in fig. 1, and the button is spring-loaded to return to the off position after operation.

5. The push-switch, Type B, No. 2, is another similar switch, with a maximum current-carrying capacity of 5 amp., but is normally closed. The push-button is coloured red, and is spring-loaded to return to the closed position after operation.

6. The push-switch, Type B, No. 3, is a single-pole change-over switch with a maximum current-carrying capacity of 5 amp.; it has four terminals. ▶

Starting switch

7. This is a push-switch for use in circuits with a current of up to 100 amp., and is designed to pass heavy currents such as occur in starting an auxiliary power unit by means of the dynamotor.

8. The mechanism of the switch is shown in fig. 2. When the button is pressed, the rim of the circular contact plate is brought into engagement with the outer and inner contacts. There are two of each of these contacts, each forming nearly a semi-circle. The upper pair is connected to one terminal and

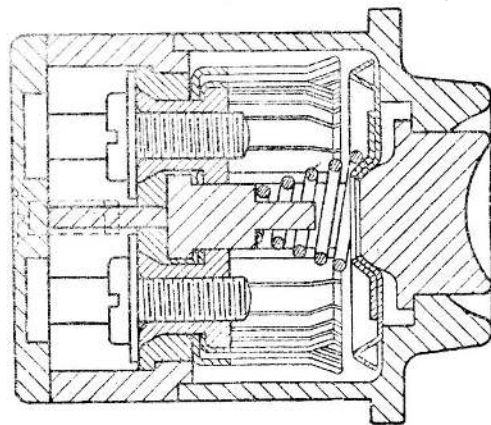

Fig. 2. Sectional view of starting switch

RESTRICTED

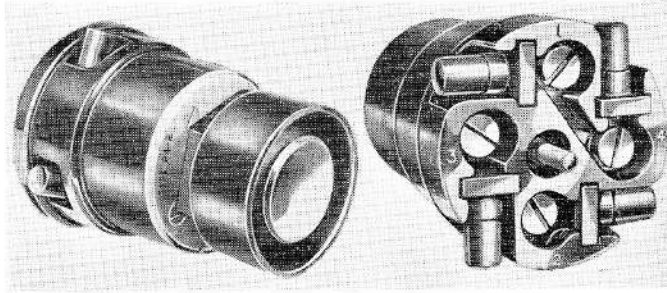

Fig. 3. Switch, Type P4/2

the lower pair to the other, and when the button is pressed the terminals are bridged. The button is spring-loaded to return to the off position after operation.

Switch, Type P4/2

9. This is a single-pole, 15-amp. change-over push-switch, and is illustrated in fig. 3 and 4. It is completely weatherproof, with a rubber cap over the push-button and rubber covers over the terminals, and the push-button is spring-loaded to return to the normal position after operation.

10. The switch has four terminals, marked 1, 2, 3 and 4, and in the normal position

connection is made between one pair of adjacent terminals. When the push-button is pressed, this pair of terminals is open-circuited and connection made between the other pair. Terminals 1 and 4 may be connected by a link, when the switch can be used as a single-pole, on/off push-switch.

SERVICING

11. No servicing is required on these switches. The action should be definite, with an immediate return of the push-button to the normal position, and switches with sticking mechanisms should be renewed.

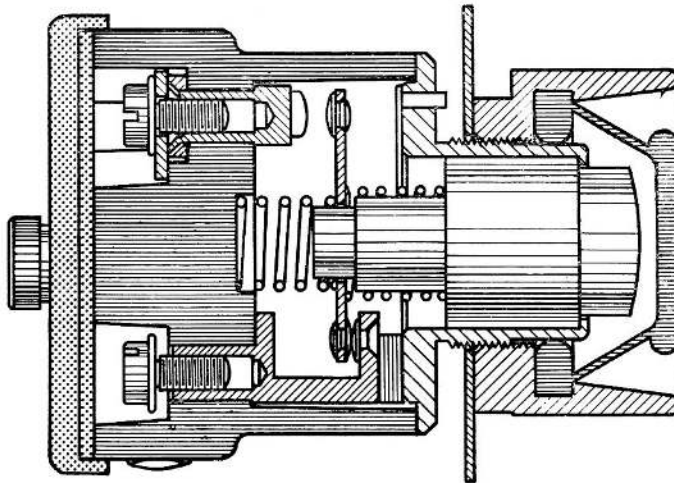

Fig. 4. Sectional view of switch, Type P4/2

RESTRICTED

Appendix I

SPRING COVERS FOR PUSH-SWITCHES

The push-switches (Ref. No. 5CW/540 and 5CW/898) may be used with the spring cover (Ref. No. 5K/2724), together with the appropriate transfer, as listed below. When two covers are required to be coupled together, the ganging rod (Ref. No. 5K/2725) should be used.

Available transfers

Ref. No.	Marking
5K/2726	Fire extinguisher
5K/2727	Engine fire extinguisher
5K/2728	Fuel tank fire extinguisher
5K/2729	Jettison live
5K/2730	Jettison live (all)
5K/2735	Danger "F"
5K/2731	Bomb release
5K/2732	Bomb circuit test
5K/2733	Boost starter
5K/2734	Control test
5K/2736	Engine starting
5K/2737	Jettison
5K/2738	Bomb jettison
5K/2739	Container jettison
5K/2740	Jettison safe
5K/2741	Jettison safe (all)
5K/2742	Jettison safe (selected only)
5K/2743	Oil dilution
5K/2744	Setting
5K/2745	Undercarriage horn test
5K/2747	Fuel tank jettison
5K/2806	Test
5K/2807	Firing
5K/2808	Loss of coolant test
5K/2810	Downward identification
5K/2811	Lifeboat
5K/2814	R.A.T.O.G. jettison
5K/2815	Bombs, pentane jettison
5K/2816	Sonobuoy jettison
5K/2817	Propeller unfeathering
5K/2818	Signal discharger
5K/2819	Hood jettison
5K/2834	Abandon aircraft
5K/2835	Defuze then jettison
5K/2858	Pressure cabin test
5K/3363	Normal
5K/3364	Ignition
5K/3365	Propeller feathering and unfeathering

White lettering
on
Red background

Red lettering on black background

White lettering
on
Black background

This file was downloaded
from the RTFM Library.

Link: www.scottbouch.com/rtfm

Please see site for usage terms,
and more aircraft documents.

