

Chapter 44

TRIM SWITCH, WESTERN, TYPE TS101

LIST OF CONTENTS

	Para.		Para.
Introduction...	1	Installation	10
Description	2	Servicing	11
Operation	7		

LIST OF ILLUSTRATIONS

	Fig.		Fig.
Trim switch, Western, Type TS 101	1	Wiring diagram	3
Sectional view of switch	2		

LEADING PARTICULARS

Trim switch, Type TS 101, Mk. 14	...	Stores Ref. 5CW/5145
Operating voltage	...	28V d.c.
Current rating	...	5 amp.
Overall dimensions—		
Length	...	7.0 in.
Width	...	2.75 in.
Depth	...	3.6 in.

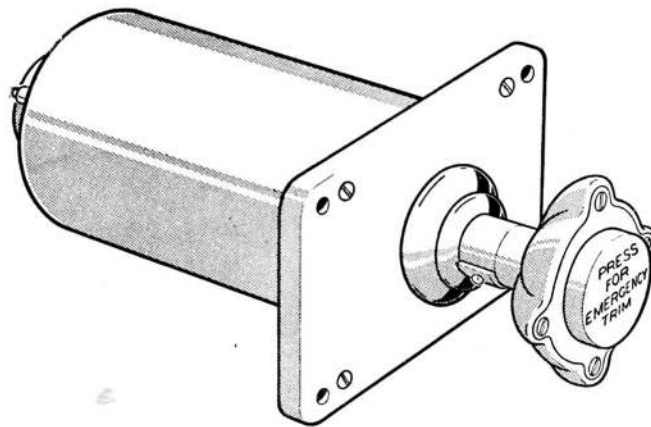

Fig. 1. Trim switch, Western, Type TS 101

Introduction

1. The trim switch, Type TS101, Mk. 14 (fig. 1) is used for switching the aileron, elevator and rudder trimming actuators on

and off. It has six normal operating positions, and a further six for emergency operation by depressing a push-button on the control knob.

(A.L.60, Mar. 56)

F.S./1

RESTRICTED

B (AL60)

DESCRIPTION

2. The trim switch (*fig. 2*) is operated by a hand control knob fastened to a shaft which carries a spherical joint on its end. The shaft carries a trip plate assembly on the inner side of the top plate, and the trip plate is so shaped that operation of the control knob to the right, left, up or down closes the appropriate micro switchette, so giving a supply to the appropriate field of the relevant trimming actuator. It will be noted from the wiring diagram in *fig. 3* that this switch differs from others with the same function in the operation of the aileron and elevator switchettes, in that movement of the knob in a certain direction has the effect of operating the switchette 90 deg. anti-clockwise from that direction, and not the switchette situated physically at that position.

3. These four switchettes, and the three for rudder and normal/emergency change-over fitted at the other end of the switch, are all Burgess, Type V3, as described elsewhere in this section. Two switchettes are fitted for rudder operation. The operating shaft carries a second trip plate assembly, so shaped that it closes one or other of the rudder switchettes as the control knob is turned clockwise or anti-clockwise. For all settings of the knob, the shaft is returned to its neutral position by spring or spring-loaded plunger action when the operating pressure is released.

4. A normal/emergency switchette is fitted at the end of the switch remote from the control knob; this is a change-over switchette, and is operated by depressing a push-button in the centre of the control knob. In certain installations this has the effect of bringing in a stand-by actuator for emergency operation of the aircraft control surfaces.

5. No image of an aircraft is reproduced on the control knob, as on some similar switches, but the action of the control knob is identical to produce the desired resultant movement of the aircraft; e.g., when the control knob is turned in a clockwise direction, the nose of the aircraft will turn to starboard.

6. The internal wiring of the switch is brought out to an 18-pole Mk. 4 miniature plug on the end of the switch. A wiring diagram is given in *fig. 3*. To gain access to the inside of the switch, remove the seal, nuts and washers from the end studs, and draw the cover away from the switch.

Operation

7. Operation of the control knob is rotary, sideways, up and down, to suit the required trimming movement of the aircraft. When the control knob is turned in a clockwise direction, the rudder is trimmed to turn the nose of the aircraft to starboard, and when the knob is turned anti-clockwise the rudder is trimmed to turn the nose of the aircraft to port.

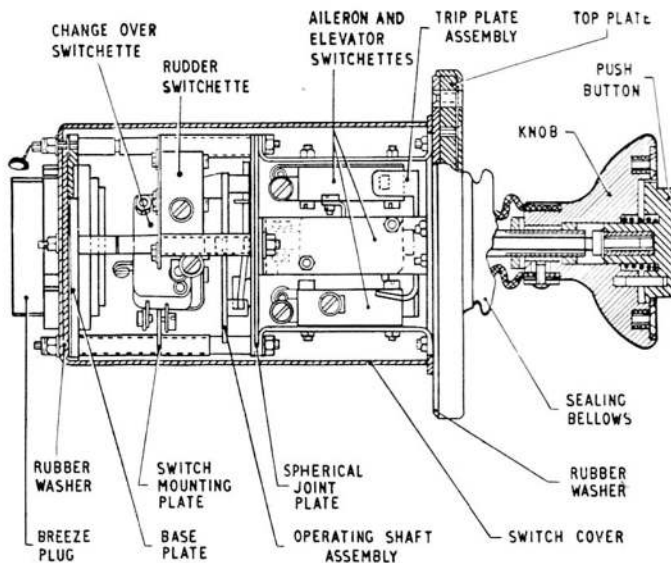

Fig. 2. Sectional view of switch

RESTRICTED

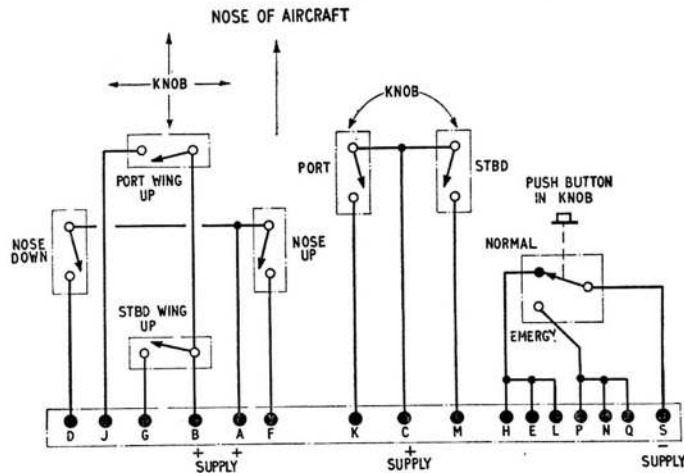

Fig. 3. Wiring diagram

8. Trimming of the aileron is brought about by pushing the control knob over to the right or to the left, movement to the right trimming the port wing up, and movement to the left trimming the starboard wing up. The elevators are trimmed by upward and downward movement of the control knob which causes the nose of the aircraft to be trimmed downward and upward respectively. When released, the control knob returns automatically to the neutral position in all instances.

9. Emergency operation of the switch is brought about by depressing the push-button in the centre of the control knob, then selecting the appropriate position as described in para. 7 and 8. Depressing the push-button on the control knob operates the normal/emergency switchette, which in certain

installations brings into circuit an alternative actuator for emergency operation of the aircraft control surfaces.

INSTALLATION

10. The switch must be mounted with the major axis of the top plate horizontal, i.e., so that the engraving on the control knob faces the operator. The method of securing is by screws or studs through the four holes in the top plate.

SERVICING

11. No servicing is permissible, apart from an inspection for freedom from damage and security of connections. The switch should operate positively for each setting of the control knob; a faulty switch must be renewed.

This file was downloaded
from the RTFM Library.

Link: www.scottbouch.com/rtfm

Please see site for usage terms,
and more aircraft documents.

