

## Chapter 47

### TIME SWITCH, VENNER, TYPE PTC/DH/20

#### LIST OF CONTENTS

	Para.		Para.
Introduction...	1	Installation	6
Description	2	Servicing	7

#### LIST OF ILLUSTRATIONS

	Fig.		Fig.
Time switch, Type PTC/DH/20	1	Wiring diagram	3
Cutaway view of mechanism	2		

#### LEADING PARTICULARS

<b>Time switch, Type PTC/DH/20</b>	...	Stores Ref. 5CW/4505
Operating voltage	...	24 d.c.
Current rating...	...	5 amp.
Timing period	...	20 sec.
Overall dimensions—		
Length	...	3 $\frac{5}{8}$ in.
Diameter	...	2 $\frac{5}{8}$ in.
Weight	...	8 oz.

#### Introduction

1. The time switch, Type PTC/DH/20 (*fig. 1*) is a clockwork-driven ignition switch in which the action of setting the pointer winds the spring and starts the timing period of 20 seconds.

#### DESCRIPTION

2. A cutaway drawing of the switch is shown in *fig. 2*. The mechanism is contained in a black plastic case, with a dial marked with white lines at the OFF and ON positions. As the operating pointer is turned to set the switch, this winds the mainspring and starts the clockwork mechanism.

3. The escapement in this mechanism is a balance operating directly off a specially-formed escape wheel without the usual inter-

mediate lever. The impulse pin, receiving impulses from the escape wheel tooth, turns the balance against the hairspring and provides a lock for the escape wheel by the balance staff. On the return of the balance the escape wheel is released via a cutaway in the balance staff.

4. The switch is provided with a set of change-over contacts, as shown in *fig. 3*, taken to terminals 1, C, and 2. In the normal application of this switch as an engine re-light switch, terminal 1 is not used. Contacts C and 2 are closed by the setting of the pointer, and open at the end of the 20-second period, when the cam follower drops off the step on the operating cam.

5. Stops on the top plate which engage with



Fig. 1. Time switch, Type PTC/DH/20

a stop on the centre spindle prevent travel of the pointer beyond the appropriate limits. The dial is protected by a transparent shield, and is located by three dowels on the top plate.

## INSTALLATION

6. This switch is designed for panel mounting, being held between the bezel and fixing strap, which is secured to the terminal end of the switch by two 2 B.A. studs and lock-nuts.

## SERVICING

7. This switch is sealed by a rubber gasket around the bezel, and should require little servicing beyond occasional oiling of the moving parts and cleaning of the contacts.

8. To gain access to the mechanism, unscrew the bezel in an anti-clockwise direction, when the mechanism can be withdrawn from the case. The following points should be lightly oiled, using oil OX-14 (Stores Ref. 34B/100589):—

- (1) All pivots, including balance staff.
- (2) Apply a spot of oil to the impulse pin and the staff where the escape wheel engages.

9. If necessary, ensure that the contacts are clean by wiping with a cloth moistened with lead-free gasoline.

### Note . . .

*The outer contacts only are used in the normal application of this switch.*

10. Turn the operating pointer to its extreme clockwise position, and check that the mechanism runs for twenty seconds. When re-fitting the bezel and bezel gasket, ensure that the dial is correctly seated on its dowels before screwing on the bezel.

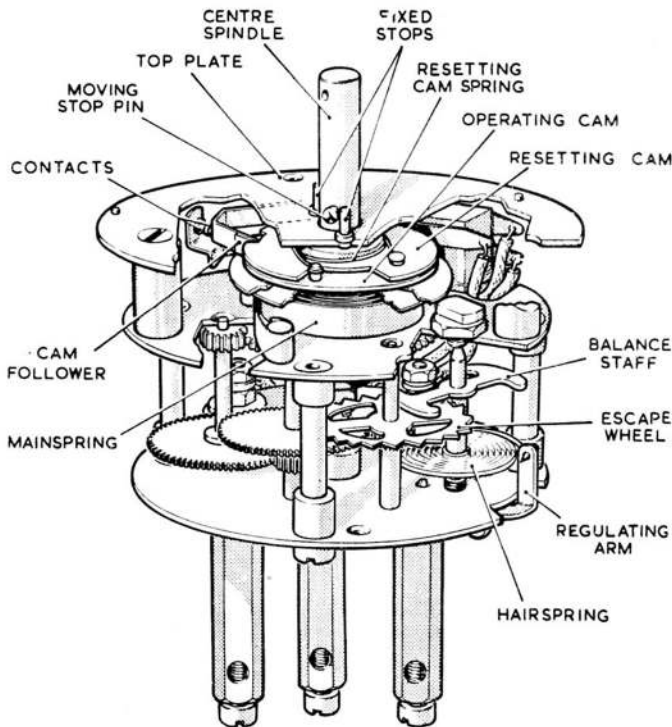

Fig. 2. Cutaway view of mechanism

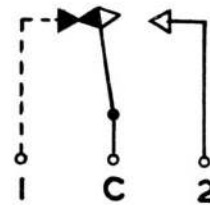

Fig. 3. Wiring diagram

**RESTRICTED**

This file was downloaded  
from the RTFM Library.

Link: [www.scottbouch.com/rtfm](http://www.scottbouch.com/rtfm)

Please see site for usage terms,  
and more aircraft documents.

