

Chapter 5

GROUND FLIGHT SWITCH, TYPE C

LIST OF CONTENTS

	Para.		Para.
Introduction	1	Operation	8
Description	2	Servicing	11
Installation	7		

LIST OF ILLUSTRATIONS

	Fig.		Fig.
Ground/flight switch, Type C	1	Sectional view of ground/flight switch	2

LEADING PARTICULARS

Ground/flight switch, Type C	Stores Ref. 5CW/2828
Height	5½ in.
Width	1 ⁷ / ₁₆ in.
Depth	4½ in.
Weight	14 oz.

Introduction

1. The ground/flight switch, Type C (*fig. 1*), is rated continuously at 120 amp. When in the GROUND position, the switch isolates the aircraft battery from the general services circuits. It connects the aircraft battery in circuit when placed in the FLIGHT position. This allows ground testing of equipment to be carried out, using a ground starter trolley battery as a source of supply.

DESCRIPTION

2. The switch is of the single-pole tumbler type. It is designed to carry 120 amp. continuously in either position, and 500 amp. for three successive cycles of ½ min. on and 1 min. off. The latter condition may occur during engine starting.

3. The base, lever and cover of the switch are of moulded bakelite construction, with a blade of high-conductivity copper inserted in the lever (*fig. 2*). The cover is secured to the base moulding by two rd/hd. screws.



Fig. 1. Ground/flight switch, Type C

(A.L.12, Apr. 55)

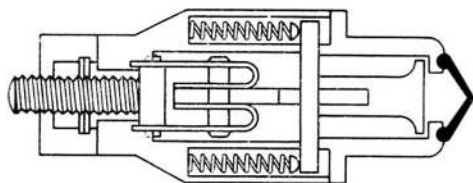
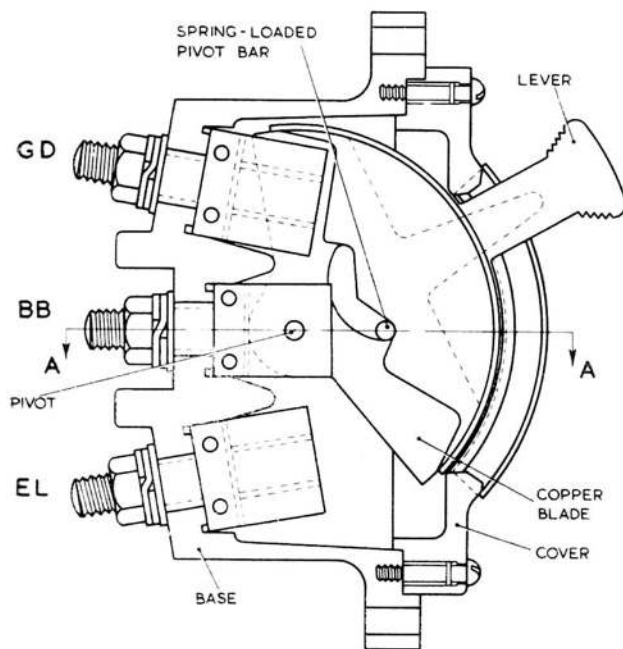

SECTION A-A

Fig. 2. Sectional view of ground/flight switch

4. The switch lever and contacts move about a pivot, bridged across the two clips of the centre contact. Snap action is ensured by a spring-loaded bar bearing on the top side of a V-shaped aperture in the lever. The bar is depressed against the action of two springs when the switch is actuated. As the bar passes the lowest point in its depression, corresponding to half the full travel distance of the lever, the spring pressure accelerates the movement of the lever, snapping it smartly into the knife contacts. As may be seen from fig. 2, there are three pairs of contacts, the blade and lever alternating between the common centre one, and either of the outer contacts as desired.

5. The terminal studs and fixed contact blocks are of copper, while the fixed contact blades, which are riveted one to each side of

the contact blocks, are of phosphor-bronze. The terminals and contacts are assembled from, and can be withdrawn through, the front of the switch.

6. Raised lettering on the base moulding indicates the terminal designation. To prevent short-circuiting of the connecting leads, two raised barriers are incorporated between the terminals. Each lead is secured to its terminal stud by a nut and a spring washer.

INSTALLATION

7. The switch may be mounted in any position convenient for wiring and accessible for operation. It is normally used in conjunction with the external supply socket described in Sect. 5 of this publication; for individual installation details, however, reference should be made to the appropriate Aircraft Handbook.

OPERATION

8. When the aircraft is on the ground with the switch in the GROUND position, the aircraft battery is isolated from the general services circuits.

9. With the switch in the GROUND position and the ground starter trolley plug inserted in the socket, the aircraft electrical services may be ground tested from the trolley battery.

10. When the aircraft engine is run up, and the switch is placed in the FLIGHT position, the electrical services are supplied by the engine-driven generator and the aircraft battery in the normal manner. It is essential that before take-off the switch is placed in the FLIGHT position.

SERVICING

11. Little servicing is normally required. During inspection, the switch blades and contacts should be lightly smeared with protective PX-7 (Stores Ref. 34B/238). An indication that the switch contacts are in good condition is given by a millivolt drop test; with a current of 80 amp. flowing, the drop between the terminal studs should not exceed 50 mV. The minimum permissible insulation resistance is 20 megohms.

RESTRICTED

This file was downloaded
from the RTFM Library.
Link: www.scottbouch.com/rtfm
Please see site for usage terms,
and more aircraft documents.

