

Chapter 56

MANUALLY OPERATED SWITCH, TYPE 3B, No. 2 (ROTAX D10102)

LIST OF CONTENTS

	Para.		Para.
Introduction	1	SERVICING	4
DESCRIPTION	2	Millivolt drop test	5
INSTALLATION	3	Insulation resistance tests	6

LIST OF ILLUSTRATIONS

	Fig.
General view of Type 3B No. 2 switch	1
Section view of switch	2
Diagram of internal connections	3

LEADING PARTICULARS

Switch, manually operated, Type 3B, No. 2	Stores Ref. 5CW/5030
Voltage	28 volts d.c.
Current rating	10 amperes
Operational ceiling	50,000 ft.
Operational temperature range	-70 deg. C. to +50 deg. C.
Diameter of body	3.000 in.
Radius of interlocking plate	1.906 in.
Height	3.750 in.
Weight	1 lb. 2 oz.



Fig. 1. General view of Type 3B, No. 2 switch

Introduction

1. The Type 3B No. 2 manual switch is a two-pole, four-way rotary selector switch designed to connect a 28 volt d.c. supply to any one of four pairs of circuits. The switch is fitted with an interlocking plate and is designed for use in conjunction with an interlocking contactor to ensure that the position of the switch cannot be altered while current is flowing.

DESCRIPTION

2. A spindle assembly rotated by a knob, is carried by a brass mounting plate and has two switching arms, each with diametrically opposed contacts. The contacts are located in set positions by a ball which runs behind the mounting plate and engages recesses in a spring plate forming part of the spindle assembly. The end of the spindle is borne by a metal insert in a moulded terminal base which has ten 4 B.A. screw and washer terminations set into it. The terminal base is secured to the mounting plate by two pillars which carry two contact rings of glassboard. Each contact ring has eight fixed contacts

RESTRICTED

spaced in four diametrically opposed pairs; and they are so arranged that in each of the four positions of the switch, each switching arm connects one pair of contacts on its respective contact ring (*internal connections fig. 3*). The switch is enclosed by a cylindrical cover and the interlocking plate is fitted to the spindle, behind the knob.

INSTALLATION

3. The switch is mounted behind a panel with only the knob accessible to the operator. It will, therefore, be necessary to remove the knob, by removing the centre screw, before securing the switch. Two mounting holes, tapped 2 B.A., are set opposite each other, the distance between fixing centres being 2.187 in.

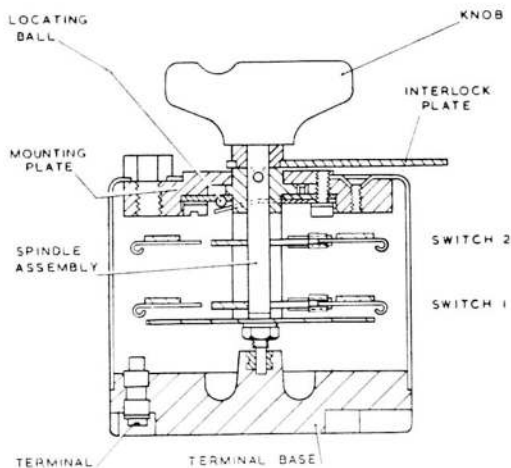

Fig. 2. Section view of switch

SERVICING

4. The tests detailed in paras. 5 and 6 are sufficient to ensure satisfactory operation of the switch. In addition, it is necessary to make a visual inspection of the switch and to ensure that the spindle rotates smoothly and locates positively in each of its four positions.

Millivolt drop test

5. Set the switch in position 1 and, allowing the rated current of 10 amperes to flow between the two terminals "1" and their respective common terminals (S1 and S2), measure the potential drop between each pair. Repeat this test in each of the three remaining positions, testing the terminals

"2", "3" and "4" in turn. The potential drop must not exceed 100 millivolts between any pair of terminals so tested.

Insulation resistance tests

6. Measure the insulation resistance between the following points, using a 250 volt insulation resistance tester:—

- Terminal S1 and adjacent terminals 2, 3, 4 and S2 (position 1)
- Terminal S1 and adjacent terminals 1, 3, 4 and S2 (position 2)
- Terminal S1 and adjacent terminals 1, 2, 4 and S2 (position 3)
- Terminal S1 and adjacent terminals 1, 2, 3 and S2 (position 4)
- Terminal S2 and adjacent terminals 2, 3 and 4 (position 1)
- Terminal S2 and adjacent terminals 1, 3 and 4 (position 2)
- Terminal S2 and adjacent terminals 1, 2 and 4 (position 3)
- Terminal S2 and adjacent terminals 1, 2 and 3 (position 4)
- Terminal S1 and frame (positions 1 to 4 in turn)
- Terminal S2 and frame (positions 1 to 4 in turn)

A reading of not less than 50,000 ohms should be obtained in each test.

Note . . .

The value given in this insulation resistance test, applies to units being tested under normal workshop conditions. Due allowance must be made for climatic conditions of the locality and those of the aircraft servicing area or dispersal point where the tests are being conducted. In damp climates the readings may be low enough to give apparently sufficient reason for rejection and, in these instances, discretion should be exercised.

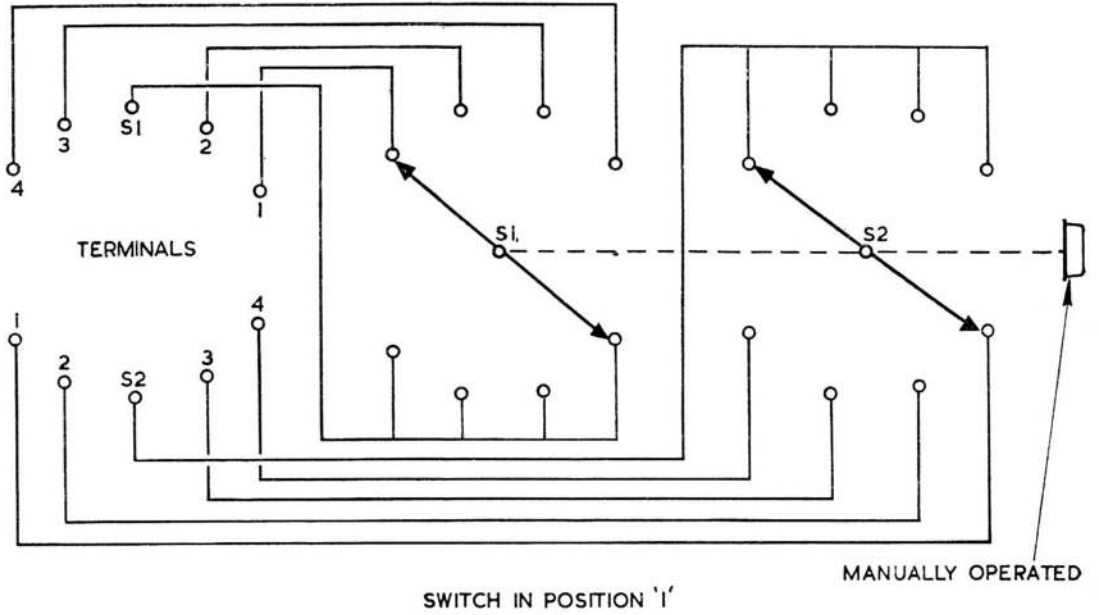

Fig. 3. Diagram of internal connections

RESTRICTED

This file was downloaded
from the RTFM Library.

Link: www.scottbouch.com/rtfm

Please see site for usage terms,
and more aircraft documents.

