

Chapter 85**TRIM SWITCH, WESTERN, TYPE TS 261****LIST OF CONTENTS**

	<i>Para.</i>		<i>Para.</i>
<i>Introduction</i>	1	Installation	7
Description	2	Servicing	8
<i>Operation</i>	6		

LIST OF TABLES

	<i>Table</i>
<i>Switch positions</i>	1

LIST OF ILLUSTRATIONS

	<i>Fig.</i>		<i>Fig.</i>
<i>Trim switch, Type TS 261</i>	1	<i>Circuit diagram</i>	3
<i>Sectional view of trim switch</i>	2		

LEADING PARTICULARS

Trim switch, Type TS 261, Mk. 19	<i>Ref. No.</i> 5CW/6801
<i>Operating voltage</i>	28 V. d.c.
<i>Current rating</i>	2.5 amp.
<i>Temperature range</i>	-40 to + 70 deg. C.
<i>Overall dimensions (in.)</i>		
<i>Length</i>	5.99
<i>Diameter of body</i>	2.5
<i>Mounting centres</i>	3 x 2.12

Introduction

1. The trim switch, Type TS 261, Mk. 19 (fig. 1) is designed primarily for use on aircraft in conjunction with an automatic pilot.

DESCRIPTION

2. A sectional view of the switch is given in fig. 2. It is operated by a hand control knob fastened to a shaft which has a universal coupling on its end. The shaft carries an operating plate, so shaped that movement of the control knob closes the appropriate micro switch, so giving a supply to the appropriate field of the relevant trimming

actuator as follows:—

- (1) Movement to port or starboard for aileron trim only.
- (2) Movement forward or aft for elevator trim only.
- (3) Movement diagonally for aileron and elevator trim simultaneously.

All micro switches are snap action, single-pole, change-over with silver contacts. The control knob is spring loaded in such a way that it returns to the neutral position when the operating pressure is released.

RESTRICTED

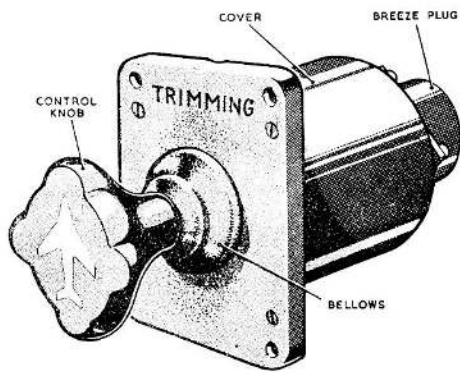

Fig. 1. Trim switch, Type TS 261

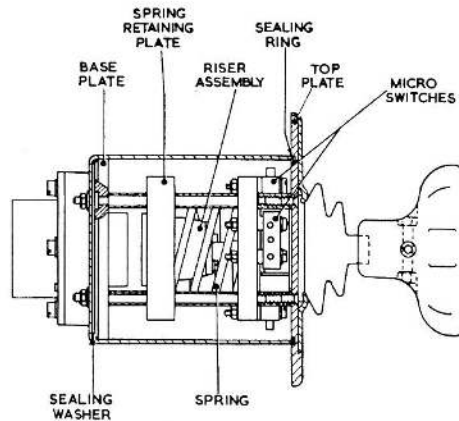

Fig. 2. Sectional view of trim switch

3. A plan view of an aircraft is reproduced on the control knob, and when the knob is operated this image indicates the resulting movement that the aircraft will make.

4. Sealing washers at each end of the cover and a bellows near the control knob are fitted but the unit is not sealed due to a $\frac{1}{8}$ in. dia. drain hole in the bottom of the cover.

5. The internal wiring of the switch is brought out to a 12-pole plug (Ref. No. 5X/6184) on the end of the switch. A

wiring diagram is given in fig. 3. To gain access to the inside of the switch, remove the seal, nuts and washers from the end studs, and draw the cover away from the switch.

Operation

6. Operation of the switch control knob to suit the required trimming movement of the aircraft is as follows:—

- (1) Movement to the right trimming the port wing up and movement to left trimming the starboard wing up.

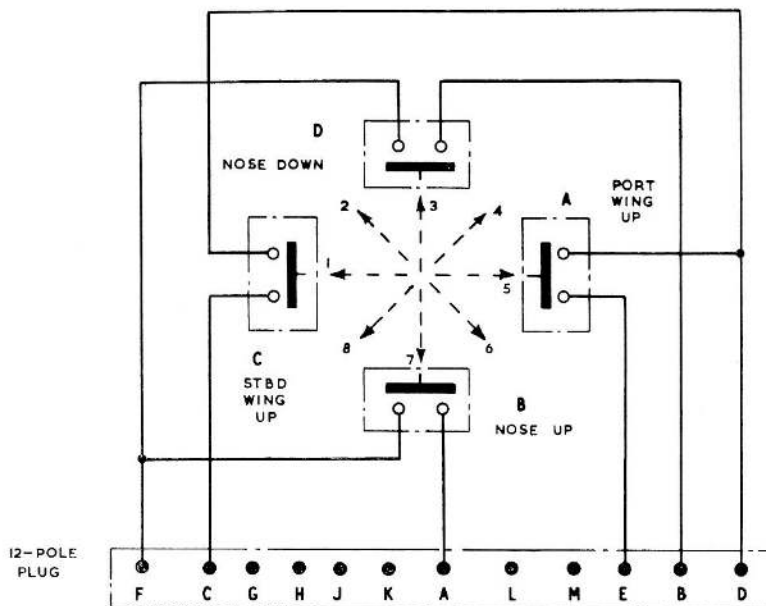

Fig. 3. Circuit diagram

RESTRICTED

- (2) Movement forward trimming the nose down and movement aft trimming the nose up.
- (3) Movement diagonally:—
- (a) Forward and left trimming the starboard wing up and nose down.
- (b) Forward and right trimming the port wing up and nose down.

- (c) Aft and left trimming the starboard wing up and nose up.
- (d) Aft and right trimming the port wing up and nose up.

When released, the control knob returns automatically to its normal position in all instances.

Table 1
Switch positions

Knob position	Switches made
1	C
2	C and D
3	D
4	D and A
5	A
6	A and B
7	B
8	B and C

INSTALLATION

7. The switch is normally mounted with the major axis of the top plate horizontal, i.e., so that the nose of the aircraft faces forward. The method of securing is by screws or studs through the four holes in the top plate.

SERVICING

8. When the control knob is moved to each of the eight positions, the smoothness of operation and return under spring pressure with no tendency to stick should be confirmed.

9. Check that the drain hole has not become blocked.

10. The millivolt drop on each individual circuit when carrying 2.5 amp. should not exceed 20 millivolts.

11. Using a 250-volt insulation resistance tester, check the insulation resistance between:—

- (1) The terminals of any two separate circuits.
- (2) All terminals connected together and the frame of the switch.

A reading of not less than 20 megohms should be obtained for each test.

RESTRICTED

This file was downloaded
from the RTFM Library.

Link: www.scottbouch.com/rtfm

Please see site for usage terms,
and more aircraft documents.



LIGHTNING MK. 1
COVER PITOT HEAD
EB2-88-511