

## Chapter 95

### LEVER SWITCHES, ARROW 93A SERIES

#### LIST OF CONTENTS

	Para.		Para.
<i>Introduction</i> ... ..	1	<b>Installation</b> ... ..	8
<b>Description</b> ... ..	2	<b>Servicing</b> ... ..	9
<i>Switch identification code</i> ... ..	5	<i>Insulation resistance test</i> ... ..	10
<i>Contact arrangement</i> ... ..	7		

#### LIST OF ILLUSTRATIONS

	Fig.
<i>Typical Arrow type 93A switches</i> ...	1

#### LIST OF APPENDICES

	App.		App.
<i>Single pole, two and three position</i> ...	1	<i>Three pole, two and three position</i> ...	4
<i>Double pole, two position</i> ... ..	2	<i>Four pole, two and three position</i> ...	5
<i>Double pole, three position</i> ... ..	3		

#### Introduction

1. This chapter covers the range of the Arrow, Type 93A lever switches which are used in aircraft for various applications. Details of individual types of this series are given in Appendices to this chapter.

#### DESCRIPTION

2. These switches, of which specimen types are illustrated in fig. 1, may be either of the following:—

	Appendix
(1) Single pole, two and three position	1
(2) Double pole, two position	2
(3) Double pole, three position	3
(4) Three pole, two and three position	4
(5) Four pole, two and three position	5

Attention is drawn to the two pole, change over types for polarity reversing as shown in fig. 1; details of which are in Appendix 2.

3. The body of these switches is of bakelite material, the switch mechanism being fully enclosed, while the exposed parts, which are visible when the switch is installed in its panel mounting, are the central bush, operating lever and terminal connections, see fig. 1.

4. Details of the different types of switch in this series, their contact arrangement, lever position and rating, are given in Appendix 1 to 5 in the order given in para. 2. All the switches in this series operate on a.c. only, their rating being 250V, 10A.

#### Switch identification code

5. The main number of this series of lever switches is 93A, the next three numbers

**RESTRICTED**

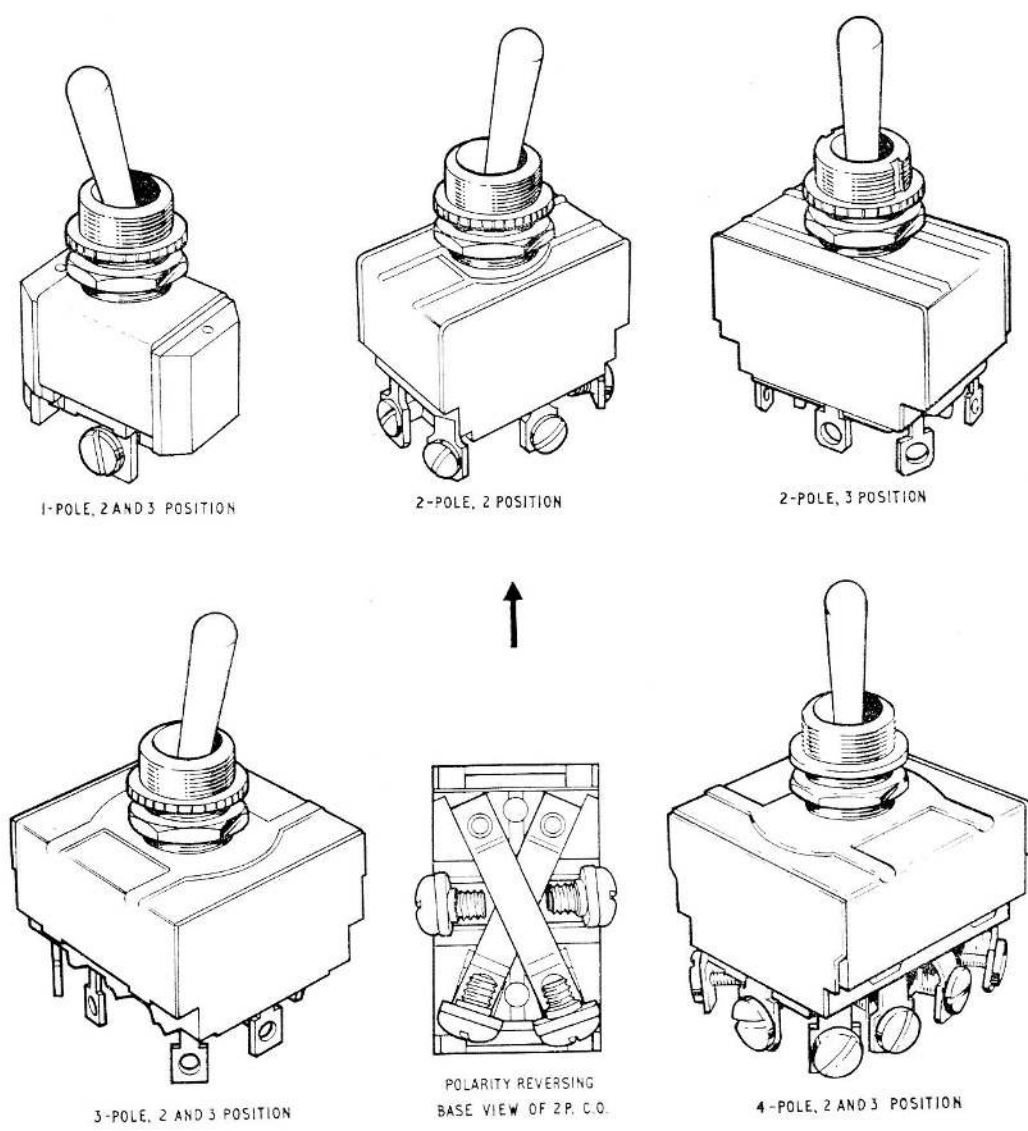

Fig. 1. Typical Arrow type 93A switches

indicate the circuitry in which the switch is used (e.g.301), this method of circuitry identification has become so complex that it no longer has any important significance, though the numbers are being retained for the present.

6. The type of terminal connections and method of securing the switch to its panel mounting is identified as follows:—

(1) Terminal connections are indicated by adding suffix letters after the circuitry coding e.g.

- Screw terminals—letter "A" e.g. 93A/301A, or
- Solder tags —letter "B" e.g. 93A/301B

(2) The method of securing switch to panel is indicated by adding suffix figures, after the method of terminal connections. One knurled ring and one hexagon nut e.g. 93A/301A/13 or, e.g. 93A/301B/13

**RESTRICTED**

**Abbreviations**

- S.P.—single pole
- D.P.—double pole
- D.T.—double throw
- T.P.—three pole
- 2.P.—two pole
- C.O.—change over

**Contact arrangements**

7. Some of the range of the 93A lever switches are designed so that they can be spring-biased, either to the "ON" or "OFF" position and for momentarily making or breaking contact; this is detailed, where relevant, in that particular Appendix.

**INSTALLATION**

8. The whole of the 93A range of lever switches is designed for single pole panel

mounting, being secured to the panel by a hexagon locknut and knurled locking ring. An outline drawing is included in each Appendix to this chapter.

**SERVICING**

9. Little servicing is necessary with this series of lever switches, apart from a visual inspection, testing for security of connections and positive action. A faulty switch must be renewed.

**Insulation resistance test**

10. Using a 250V d.c. insulation resistance tester, measure the insulation resistance between all live parts and metal (earth) parts of the switch; this should not be less than 5 megohm (R.A.F.) and 0.5 megohm (R.N.).

**RESTRICTED**

### Appendix 1

## SINGLE POLE, TWO AND THREE POSITION (250V, a.c., 10A rating)

Code	Ref. No. 5CW/	Circuit contact arrangement	Lever positions
93A/403		S.P. On-Off	Off-None-On
93A/507		{ S.P. On-Off Biased "On"	Off-None-On
93A/508		{ S.P. On-Off Biased "Off"	Off-None-On
93A/401		S.P. D.T.	On-None-On
93A/501		{ S.P. D.T. Biased	On-None-On
93A/101		S.P. D.T.	On-Off-On
93A/201		{ S.P. D.T. Biased one way	On-Off-On
93A/301/13		{ S.P. D.T. Biased both ways	On-Off-On

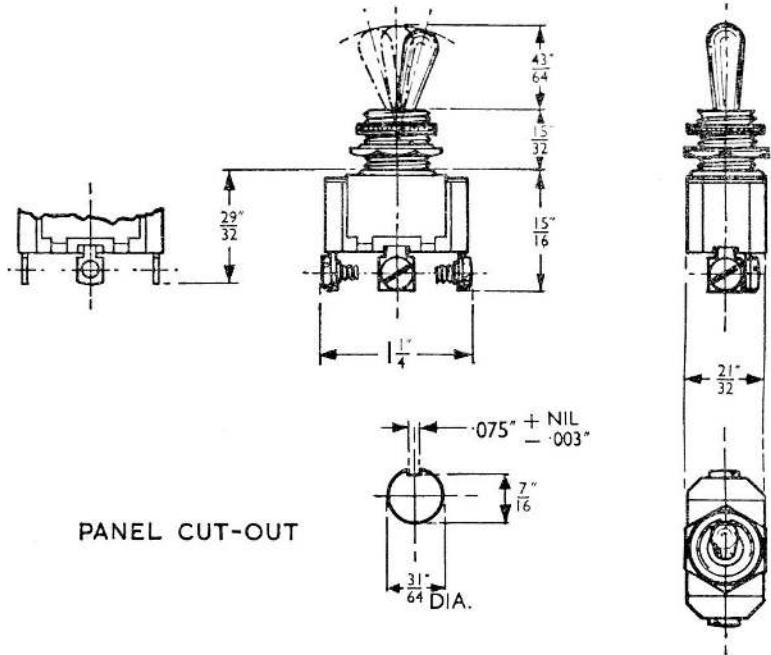

Fig. 1. Single pole switch, two and three position

**RESTRICTED**

## Appendix 2

### DOUBLE POLE, TWO POSITION (250V, a.c., 10A rating)

Code	Ref. No. 5CW/	Circuit contact arrangement
93A/404		D.P. On-Off
93A/510		D.P. On-Off Biased Off
93A/509		D.P. On-Off Biased On
93A/402		D.P. D.T.
93A/502		D.P. D.T. Biased
93A/406		2.P. C.O.
93A/506		2.P. C.O. Biased
93A/405		S.P. 2 circuit
93A/505		S.P. 2 circuit Biased

} Designed for polarity reversing, see fig. 1 in main chapter.

Constructed on slightly larger bakelite bases than the single pole types. Attention is drawn to the 2-pole changeover types for polarity reversing (Chap. 95, fig. 1) and this Appendix.

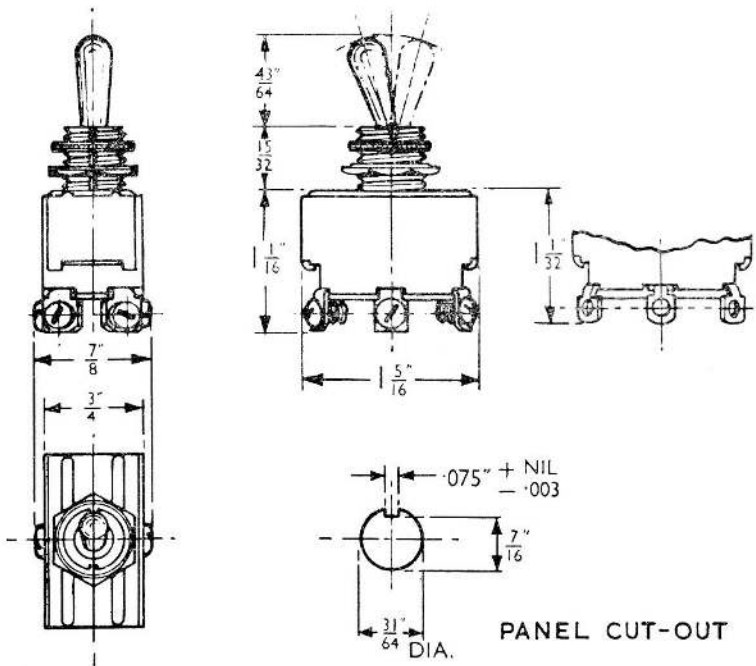

Fig. 1. Double pole switch, two position

**RESTRICTED**

### Appendix 3

## DOUBLE POLE, THREE POSITION (250V a.c., 10A rating)

Code	Ref. No. 5CW/	Circuit contact arrangement	Lever positions
93A/102		D.P. D.T.	On-Off-On
93A/202		D.P. D.T.	On*-Off-On
93A/302		D.P. D.T.	On*-Off*-On
93A/105		S.P. 2 circuit	On-Off-On
93A/205		S.P. 2 circuit	On*-Off-On
93A/305		S.P. 2 circuit	On*-Off*-On
93A/106		2.P. C.O.	On-Off-On
93A/206		2.P. C.O.	On*-Off-On
93A/306		2.P. C.O.	On*-Off*-On
93A/111		{ 2 circuit collective	Off-On-On (A) (A and B)

\* Indicates biased position

Constructed on the same base as the two position type shown in Appendix 2, these switches, by virtue of having three positions, cover an extremely versatile range of circuits. Where an Off position is not required, even more flexibility of circuit arrangement can be obtained, with or without biased position.

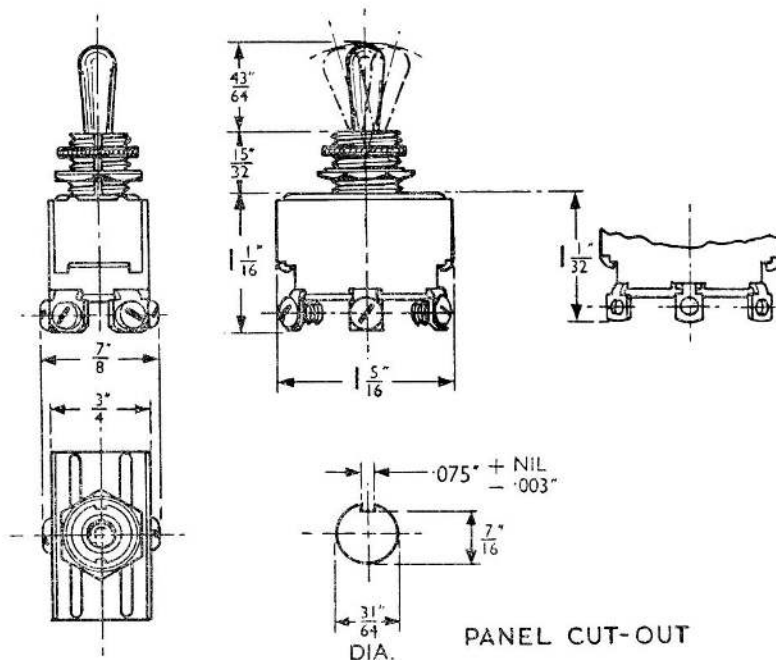

Fig. 1. Double pole switch, three position

RESTRICTED

## Appendix 4

### THREE POLE, TWO AND THREE POSITION (250V, a.c., 10A rating)

Code	Ref. No. 5CW/	Circuit contact arrangement	Lever positions
93A/413		T.P. On-Off	Off-None-On
93A/514		T.P. On-Off biased Off	Off-None-On
93A/515			Off-None-On
93A/416		T.P. D.T.	On-None-On
93A/516		T.P. D.T. biased	On-None-On
93A/116			On-Off-On
93A/216		T.P. D.T. biased one way	On-Off-On
93A/316			On-Off-On
		T.P. D.T. biased both ways	

Manufactured on slightly larger bases than the two pole types these switches provide for further variations of circuit arrangement.

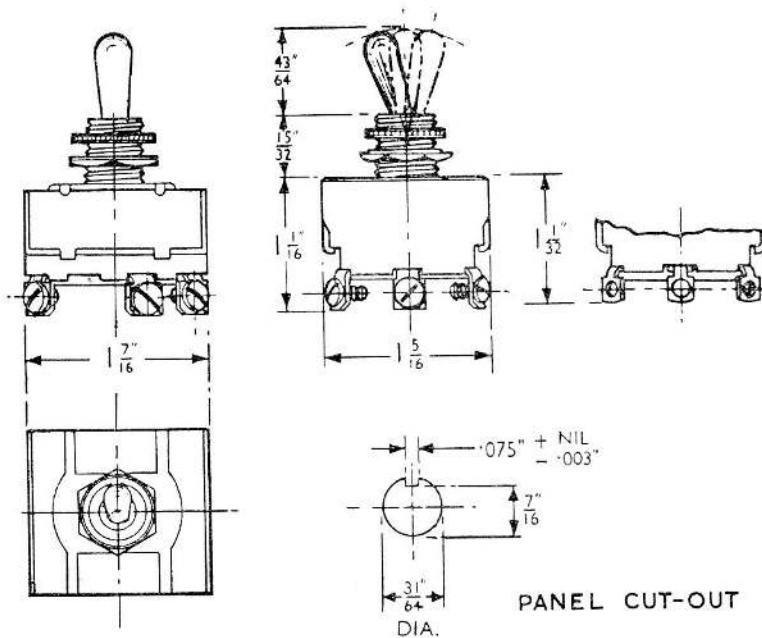

Fig. 1. Three pole switch, two and three position

**RESTRICTED**

## Appendix 5

### FOUR POLE, TWO AND THREE POSITION (250V, a.c., 10A rating)

Code	Ref. No. 5CW/	Circuit contact arrangement	Lever positions
93A/417		F.P. On-Off	Off-None-On
93A/518		{ F.P. On-Off biased Off	Off-None-On
93A/519		{ F.P. On-Off biased On	Off-None-On
93A/420		F.P. D.T.	On-None-On
93A/520		{ F.P. D.T. biased	On-None-On
93A/120		F.P. D.T.	On-Off-On
93A/220		{ F.P. D.T. biased one way	On-Off-On
93A/320		{ F.P. D.P. biased both ways	On-Off-On

Manufactured on the same design base as the three pole types, these four pole switches operate in either two or three position arrangements, biased one or both ways if required.

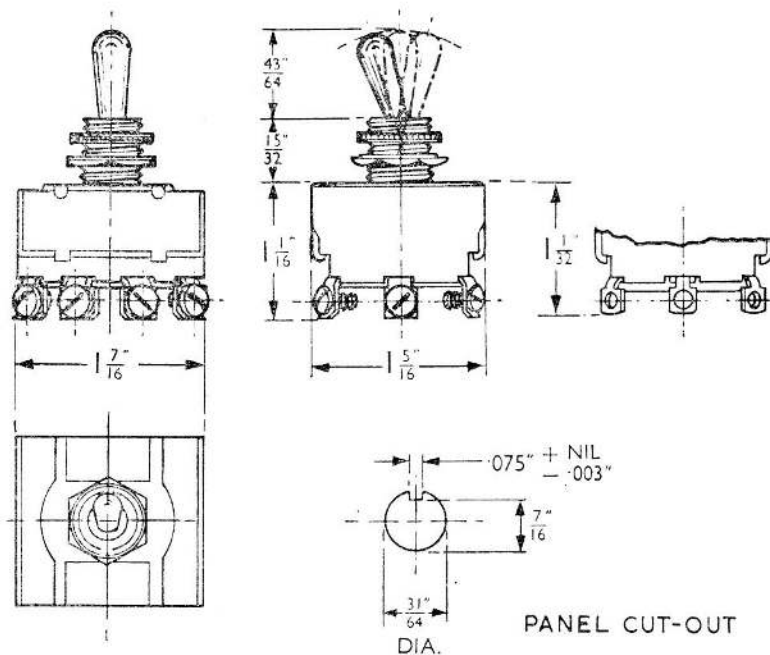

Fig. 1. Four pole switch, two and three position

**RESTRICTED**

This file was downloaded  
from the RTFM Library.

Link: [www.scottbouch.com/rtfm](http://www.scottbouch.com/rtfm)

Please see site for usage terms,  
and more aircraft documents.

