

Chapter 96

MANUALLY OPERATED SWITCH, ROTAX, TYPE D1402

LIST OF CONTENTS

	<i>Para.</i>		<i>Para.</i>
<i>Introduction</i>	1	Installation	10
Description	3	Servicing	11
<i>Operation</i>	6	<i>Testing</i>	12
<i>Electrical connections</i>	9		

LIST OF ILLUSTRATIONS

	<i>Fig.</i>
<i>Installation diagram</i>	1

LIST OF APPENDICES

	<i>App.</i>
<i>Standard serviceability test for manually operated switch, Rotax, Type D1402</i> ..	A

LEADING PARTICULARS

Switch, manually operated, Type D1402	Ref. No. 5CW/1632
<i>Voltage</i>	28 volts d.c.
<i>Current rating</i>	10 amp. (continuous)
<i>Mounting</i>	Panel fitting
<i>Weight</i>	4 oz. (approx.)

Introduction

1. The D1402 manually operated switch has four positions, three separate ON positions and a central OFF position. The central OFF position is with the knob pulled out.

2. For reference, it may be noted that Type D1401 (Ref. No. 5CW/1563) is identical in operation to the D1402 detailed in this chapter; the only difference is the addition of a warning lamp of the H2700 series incorporated in the mounting panel of the switch, as shown dotted in fig. 1.

DESCRIPTION

3. The switch comprises three main assemblies, a spindle and contact wiper assembly, incorporating the indicator knob; the ter-

minal and contact moulding assembly, including a rear spindle bearing; finally the body assembly, which includes the mounting flange and the front spindle bearing at one end with the terminal cover at the opposite end.

4. The spindle and contact wiper are carried in two plain bearings, the bearing at the mounting flange end being an integral part of the body assembly, and the terminal moulding providing the other plain bearing. This bearing is in the form of a moulded in bush to accept the minor diameter of the knob and contact wiper assembly. The bearing bush also provides a threaded end that projects through the moulding for securing the terminal cover via its captive screw.

RESTRICTED

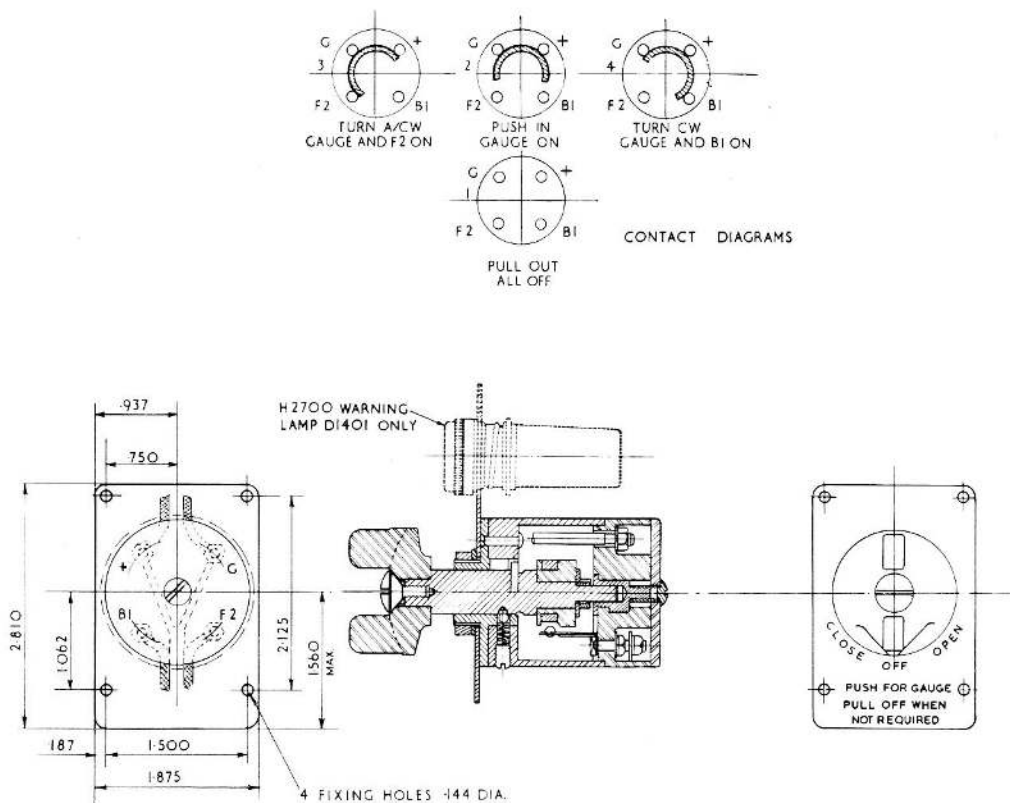

Fig. 1. Installation diagram

5. When the spindle and contact wiper is pushed IN, it is held under pressure through a spring-loaded ball locating in a key seat in the spindle. A force of 12 lb. is required to pull the spindle out by the indicating knob, and it is held in the OUT position by the spring-loaded ball snapping into an annular groove machined in the spindle, adjacent to the integral wiper contact moulding.

Operation

6. The knob and associated spindle carrying the contact wiper is located in the OUT and IN positions by a spring-loaded ball, which positions the contact wiper when in either the OUT or IN position to ensure a good snap action. The four switch positions, with snap action location on each, are as follows:

(1) With the switch knob in the central position, i.e. white indicator pointing to OFF on mounting panel, and knob pulled out. In this position it should not be possible to rotate the knob in either direction.

(2) With the switch still in the central position but pushed in.

(3) Switch the knob from the pushed-in position to anti-clockwise, with the white indicator pointing to OPEN on the mounting panel. It should not be possible to turn beyond this point.

(4) Switch knob from the central push-in position and turn clockwise, with white indicator pointing to CLOSE on mounting panel. It should not be possible to turn beyond this point.

7. The snap actions between positions 1 and 2, and positions 2, 3 and 4 should be positive and smooth and free from jerks. If when rotating from position 2 to positions 3 or 4 there is any over-run beyond the snap action location, the mechanism should drop back without hesitation into this location.

RESTRICTED

8. The force necessary to pull out the switch knob from position 2 to position 1 should not exceed 12 lb.

Electrical connection

9. The electrical connections relative to the switch knob indicator positions are as follows:—

- (1) All terminals isolated, i.e. +, G, B1 and F2.
- (2) Terminals + and G connected, terminals B1 and F2 isolated.
- (3) Terminals +, G and F2 connected, terminal B1 isolated.
- (4) Terminals +, G and B1 connected, terminal F2 isolated.

INSTALLATION

10. The unit is secured on its mounting

panel via four fixing holes 0.144 in. diameter; the linear travel of the switch knob from the ON position to the full out or OFF position is 0.187 in. The diameter cut-out in the installation mounting panel should not be less than 1.750 in. diameter. Further information is given in the installation diagram (fig. 1).

SERVICING

11. Remove the terminal cover and ensure that the four terminal connections are secure. Operate the switch as detailed in para. 6 (1), (2), (3) and (4), 7 and 8 under the heading Operation and ensure that the connections are as detailed in para. 9 (1), (2), (3) and (4) for each position respectively.

Testing

12. If the serviceability of the switch is suspect, it may be tested as laid down in Appendix A.

Appendix A

STANDARD SERVICEABILITY TEST

FOR MANUALLY OPERATED SWITCH, ROTAX, TYPE D1402

Introduction

1. The following tests may be applied to the switch before it is put into service, or at any time when its serviceability is suspect.

Test equipment

2. The following test equipment is required:

- (1) Suitable 0—15A d.c. ammeter.
- (2) Multimeter, Type 12889 (Ref. No. 5QP/17447) or equivalent.
- (3) Insulation resistance tester, Type C (Ref. No. 5G/152).

Testing

Millivolt drop test

3. With the rated current of 10 amp. at 28 volts flowing through each circuit in turn, the millivolt drop from + to G in positions 2, 3 and 4, and from + to F2 and B1 in positions 3 and 4 respectively, should be not more than 100 mV.

Insulation resistance test

4. The insulation resistance, when measured with a 250-volt insulation resistance tester between the following points, should not be less than 0.5 megohm (for R.N.), or 5 megohms (for R.A.F.):

<i>Switch position</i>	<i>Terminal connection</i>
1 Knob pulled out	Between all terminals individually
2 Knob pushed in	Between all terminals and switch frame Between terminals + and B1 Between terminals + and F2
3 Knob turned anti-clockwise	Between terminals + and B1
4 Knob turned clockwise	Between terminals + and F2

This file was downloaded
from the RTFM Library.
Link: www.scottbouch.com/rtfm

Please see site for usage terms,
and more aircraft documents.

